

STM8 Nucleo-32 board (MB1442)

Introduction

The NUCLEO-8S207K8 STM8 Nucleo-32 board featuring the STM8S207K8T6C STM8 8-bit MCU provides an affordable and flexible way for users to try out new concepts and build prototypes with STM8S Series microcontrollers in LQFP32 package, choosing from the various combinations of performance, power consumption, and features. The ARDUINO® Nano connectivity support makes it easy to expand the functionality of the Nucleo-32 open development platform with a wide choice of specialized shields. The STM8 Nucleo-32 board does not require any separate probe as it integrates the ST-LINK/V2-1 debugger/programmer and comes with the STM8 standard peripheral library, together with various packaged software examples.

Figure 1. NUCLEO-8S207K8 top view

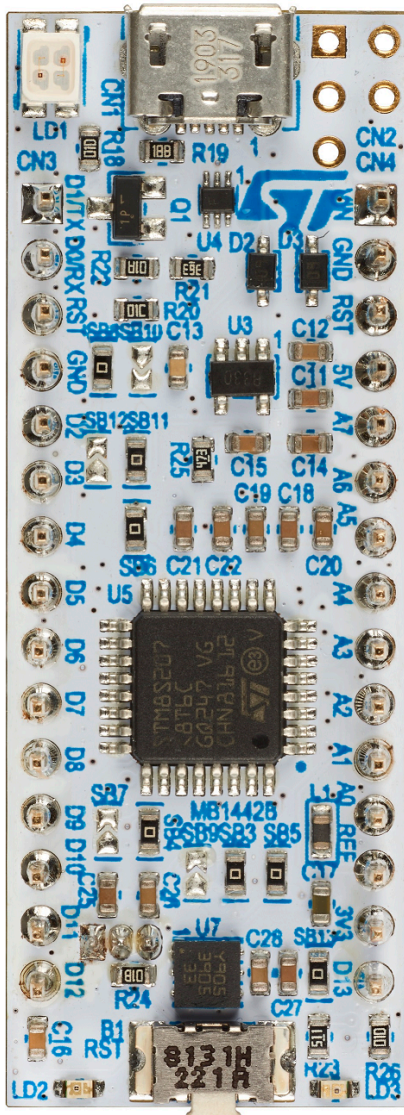
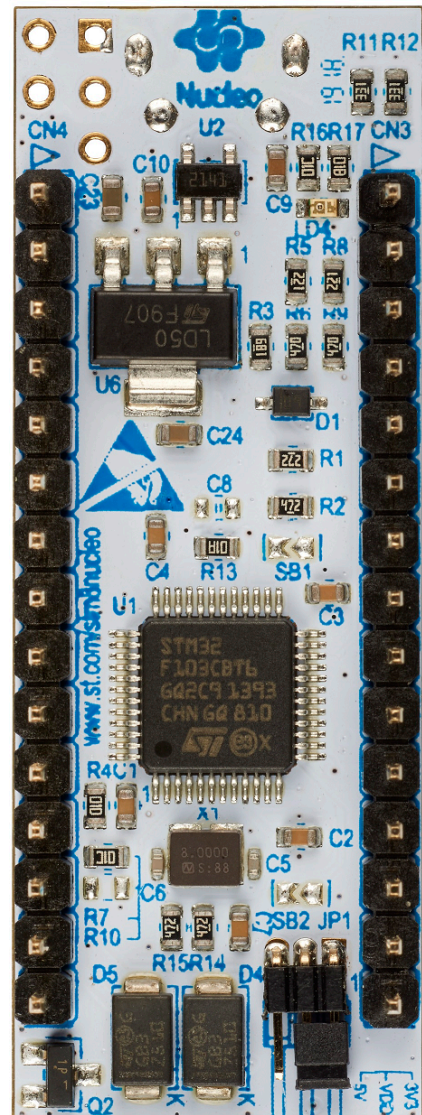

Figure 2. NUCLEO-8S207K8 bottom view



Pictures are not contractual.

1 Features

- STM8 microcontroller in LQFP32 32-pin package
- 4 LEDs:
 - USB communication (LD1)
 - Power (LD2)
 - User (LD3)
 - Default (LD4)
- 1 reset push-button
- Board connectors:
 - ARDUINO® Nano V3 expansion connector
 - Micro-B USB connector for the ST-LINK
 - SWIM interface
- Flexible power-supply options: ST-LINK USB V_{BUS} or external sources (3.3 V, 5 V, 7 V – 12 V)
- On-board ST-LINK/V2-1 debugger/programmer with SWIM connector and USB re-enumeration capability: mass storage, Virtual COM port and debug port
- Comprehensive free software STM8 libraries including a variety of software examples
- Support of a wide choice of Integrated Development Environments (IDEs) including STMicroelectronics free STVD-STM8 (using Cosmic toolchain), IAR™, Cosmic free IDEA

2 Ordering information

To order the STM8 Nucleo-32 board, refer to [Table 1](#). Additional information is available from the datasheet and reference manual of the target STM32.

Table 1. Ordering information

Order code	Board reference	Target STM32
NUCLEO-8S207K8	MB1442	STM8S207K8T6C

2.1 Product marking

Evaluation tools marked as “ES” or “E” are not yet qualified and therefore not ready to be used as reference design or in production. Any consequences deriving from such usage will not be at ST charge. In no event, ST will be liable for any customer usage of these engineering sample tools as reference designs or in production.

“E” or “ES” marking examples of location:

- On the targeted STM8 that is soldered on the board (for illustration of STM8 marking, refer to the STM8 datasheet “Package information” paragraph at the www.st.com website).
- Next to the evaluation tool ordering part number that is stuck or silk-screen printed on the board.

2.2 Codification

The meaning of the codification is explained in [Table 2](#).

Table 2. Codification explanation

NUCLEO-XXYYYYKT	Description	Example: NUCLEO-8S207K8
XX	MCU series in STM8 8-bit MCUs	STM8S Series
YYY	MCU product line in the series	STM8S207
K	STM8 package pin count	32 pins
T	STM8 Flash memory size: <ul style="list-style-type: none"> • 3 for 256 bytes • 4 for 16 Kbytes • 6 for 32 Kbytes • 8 for 64 Kbytes • B for 128 Kbytes 	64 Kbytes

The order code is mentioned on a sticker placed on the top side of the board.

3 Development environment

3.1 System requirements

- Windows® OS (7, 8 and 10)
- USB Type-A to Micro-B cable

3.2 Development toolchains

- STMicroelectronics: free STVD-STM8 (using Cosmic toolchain)
- IAR™: IAR-EWSTM8
- Cosmic: free IDEA

3.3 Demonstration software

The demonstration software is preloaded in the STM8 Flash memory for easy demonstration of the device peripherals in standalone mode. The latest versions of the demonstration source code and associated documentation can be downloaded from the demonstration resource section of the STM8 Nucleo board webpage at www.st.com.

4 Conventions

Table 3 provides the conventions used for the ON and OFF settings in the present document.

Table 3. ON/OFF convention

Convention	Definition
Jumper JPx ON	Jumper fitted
Jumper JPx OFF	Jumper not fitted
Jumper JPx [1-2]	Jumper should be fitted between Pin 1 and Pin 2
Solder bridge SBx ON	SBx connections closed by 0 Ω resistor
Solder bridge SBx OFF	SBx connections left open
Resistor Rx ON	Resistor soldered
Resistor Rx OFF	Resistor not soldered

5 Quick start

The [NUCLEO-8S207K8](#) STM8 Nucleo-32 board featuring the [STM8S207K8T6C](#) STM8 8-bit MCU provides an affordable and flexible way for users to try out new concepts and build prototypes with an STM8S Series microcontroller in an LQFP32 package.

Before installing and using the product, accept the Evaluation Product License Agreement from the www.st.com/epl webpage.

For more information on the STM8 Nucleo-32 board and to access demonstration software, visit the www.st.com webpage.

5.1 Getting started

1. Check jumper position onboard: JP1 (VDD) on [1-2] or [2-3] position.
2. Connect the STM8 Nucleo board to a PC with a Type-A to Micro-B USB cable through the USB connector CN1 to power the board. Then LED LD1 (COM) and red LED LD2 (PWR) light up, the green LED LD3 blinks.
3. Remove the jumper placed between D2 (CN3 pin 5) and GND (CN3 pin 4).
4. Observe how the blinking of green LED LD3 changes when the jumper is in place or removed.
5. Download the demonstration software and several examples that help to use the STM8 Nucleo features. These are available at the [NUCLEO-8S207K8](#) product webpage.
6. Develop your own applications using the provided examples.

6 Hardware layout and configuration

The STM8 Nucleo-32 board is designed around an STM8S Series microcontroller in an LQFP32 package.

Figure 3 shows the connections between the STM8 and its peripherals (ST-LINK/V2-1, push-button, LED, and ARDUINO® Nano V3 expansion connector).

Figure 4 and Figure 5 show the location of these features on the STM8 Nucleo-32 board.

The mechanical dimensions of the board are shown in Figure 6.

Figure 3. Hardware block diagram

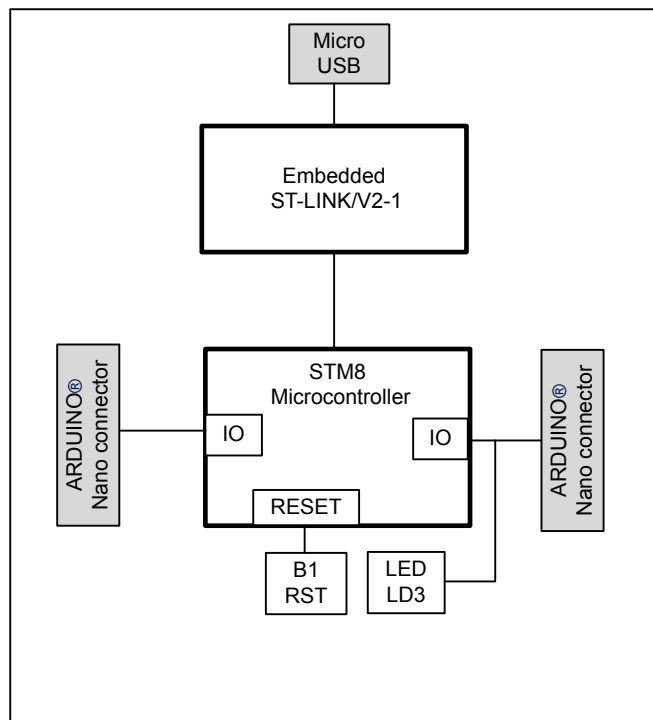

6.1 STM8 Nucleo-32 board layout

Figure 4. STM8 Nucleo-32 board top layout

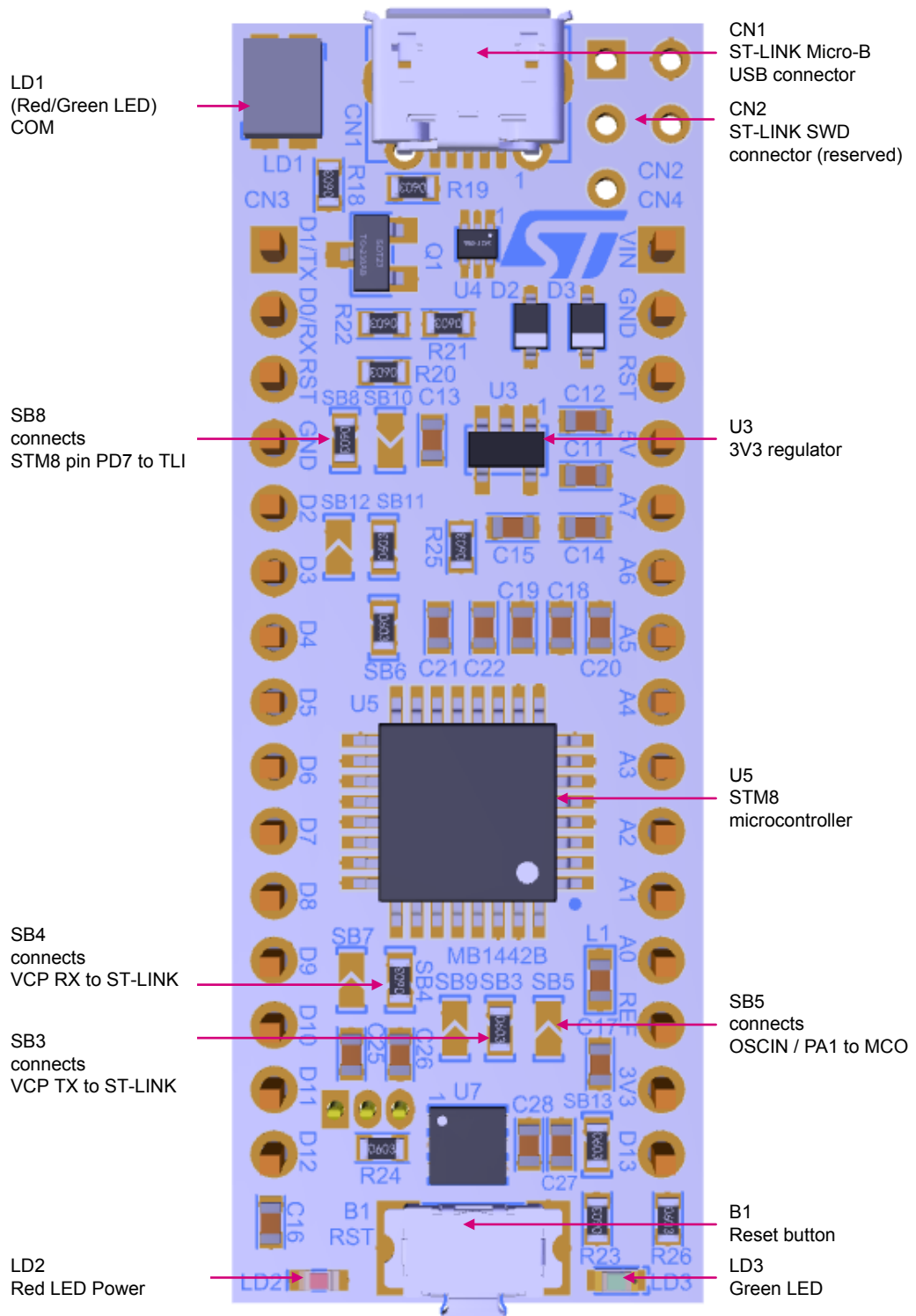
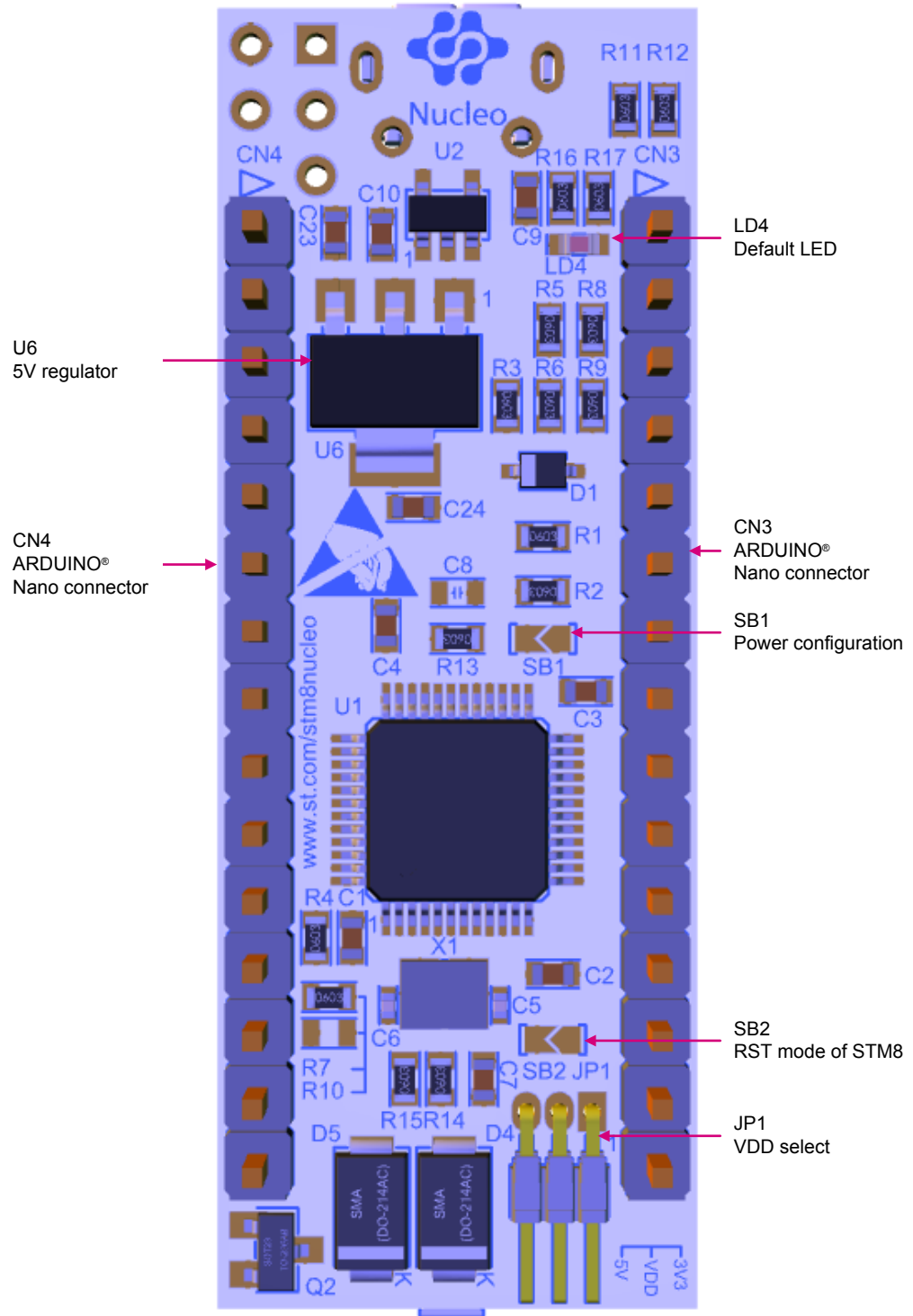
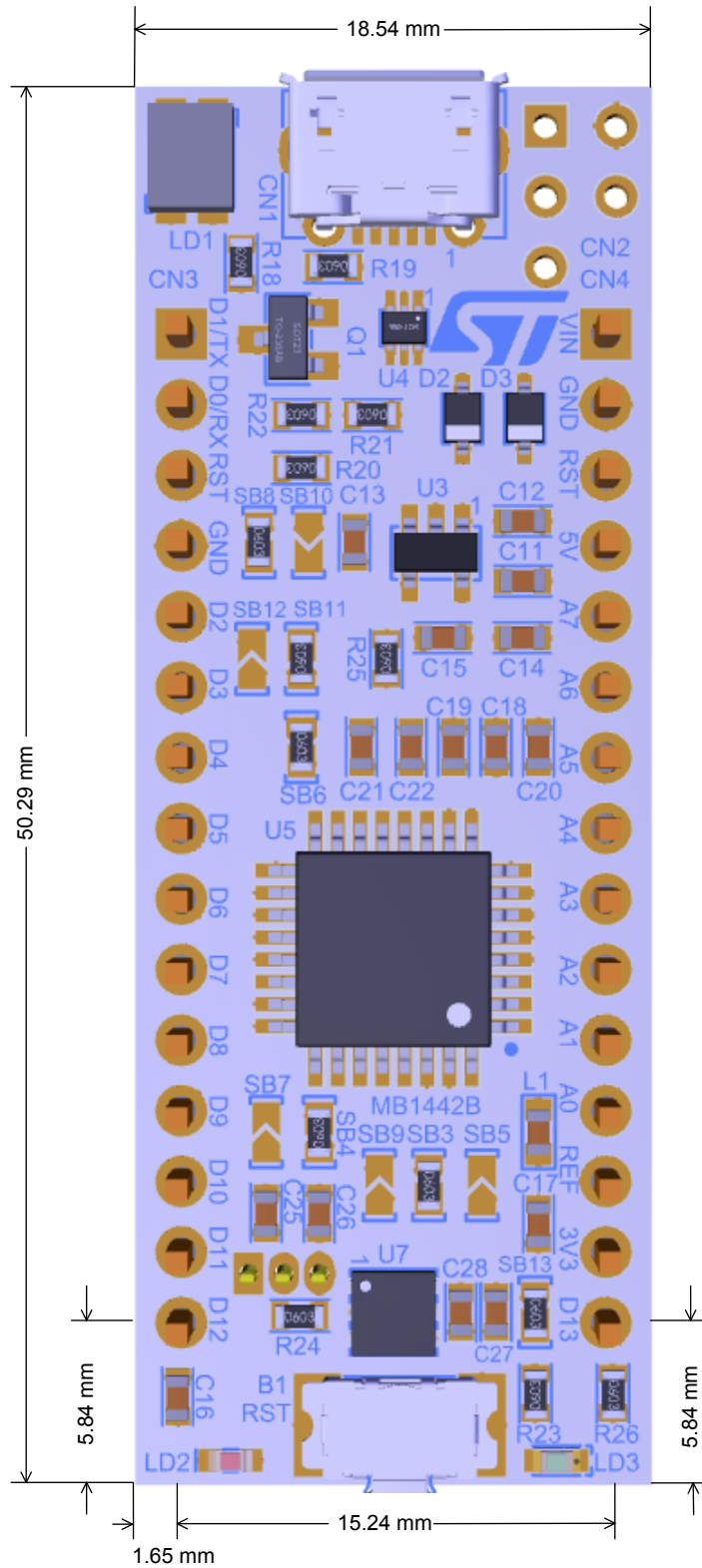

Figure 5. STM8 Nucleo-32 board bottom layout



6.2 Mechanical drawing

Figure 6. STM8 Nucleo-32 board mechanical drawing (in millimeter)



6.3 Embedded ST-LINK/V2-1

The ST-LINK/V2-1 programming and debugging tool is integrated into the STM8 Nucleo-32 board.

For detailed information about the debugging and programming features of ST-LINK/V2-1, refer to the *ST-LINK/V2 in-circuit debugger/programmer for STM8 and STM32 user manual (UM1075)* and *Overview of ST-LINK derivatives technical note (TN1235)*.

Features supported by the ST-LINK/V2-1:

- USB software re-enumeration
- Virtual COM port interface on USB
- Mass storage interface on USB
- USB power management request for more than 100 mA power on USB

Features not supported on ST-LINK/V2-1:

- SWIM interface

The embedded ST-LINK/V2-1 is directly connected to the SWIM port of the target STM8.

6.3.1 Drivers

The ST-LINK/V2-1 requires a dedicated USB driver, which, for Windows 7®, Windows 8® and Windows 10®, is found at www.st.com.

In case the STM8 Nucleo-32 board is connected to the PC before the driver is installed, some STM8 Nucleo-32 interfaces may be declared as “Unknown” in the PC device manager. In this case, the user must install the dedicated driver files, and update the driver of the connected device from the device manager as shown in Figure 7.

Note: Prefer using the USB Composite Device handle for a full recovery.

Figure 7. USB composite device

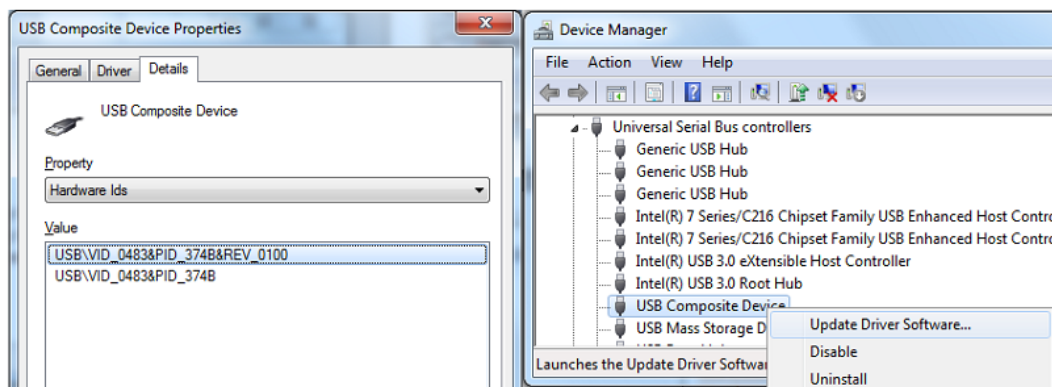

6.3.2 ST-LINK/V2-1 firmware upgrade

The ST-LINK/V2-1 embeds a firmware mechanism for the in-situ upgrade through the USB port. As the firmware may evolve during the lifetime of the ST-LINK/V2-1 product (for example new functionalities, bug fixes, support for new microcontroller families), it is recommended to visit the www.st.com website before starting to use the STM8 Nucleo-32 board and periodically, to stay up-to-date with the latest firmware version.

6.4 Power supply and power selection

The power supply is provided either by the host PC through the USB cable, or by an external source: VIN (7 V-12 V), 5V or 3V3 power supply pins on CN4. In case VIN, 5V or 3V3 is used to power the STM8 Nucleo-32 board, this power source must comply with the standard EN-60950-1: 2006+A11/2009, and must be Safety Extra Low Voltage (SELV) with limited power capability.

The MCU power supply is also selectable: 3V3 or 5V.

6.4.1 Power supply input from the USB connector

The STM8 Nucleo-32 board and shield board can be powered from the ST-LINK USB connector CN1. Note that only the ST-LINK part is power supplied before the USB enumeration phase, as the host PC only provides 100 mA to the boards at that time. During the USB enumeration, the STM8 Nucleo-32 board requires 300 mA of current to the host PC. If the host is able to provide the required power, the targeted STM8 microcontroller is powered and the red LED LD2 is turned on, thus the STM8 Nucleo-32 board and its shield consume a maximum of 300 mA current and not more. If the host is not able to provide the required current, the targeted STM8 microcontroller and the shield board are not power supplied. As a consequence, the red LED LD2 stays turned off. In such a case, it is mandatory to use an external power supply as explained in the next [Section 6.4.2 External Power supply inputs](#).

SB1 is configured according to the maximum current consumption of the board. SB1 can be set to ON to inform the host PC that the maximum current consumption does not exceed 100 mA (even when ARDUINO® Nano shield is plugged). In such a condition, USB enumeration always succeeds since no more than 100 mA is requested to the host PC. Possible configurations of SB1 are summarized in [Table 4](#).

Table 4. SB1 configuration

Solder bridge state ⁽¹⁾	Power supply	Maximum current
SB1 OFF	USB power through CN1	300 mA
SB1 ON		100 mA

1. The default configuration is reported in bold style.

Caution: If the maximum current consumption of the STM8 Nucleo-32 board and its shield board exceeds 300 mA, it is mandatory to power the STM8 Nucleo-32 board, using an external power supply connected to VIN, 5V or 3V3.

Note: In case the board is powered by a USB charger, there is no USB enumeration, so the LED LD2 remains set to off permanently and the target STM8 is not powered. In this specific case, the SB1 must be set to ON, to allow the target STM8 to be powered anyway.

6.4.2 External Power supply inputs

The STM8 Nucleo-32 board and its shield boards can be powered in three different ways from an external power supply, depending on the voltage used. The three power sources are summarized in [Table 5](#).

Table 5. External power sources

Input power name	Connector pins	Voltage range	Max. current	Limitation
VIN	CN4 pin 1	7 to 12 V	800 mA	From 7 to 12 V only and input current capability is linked to input voltage: <ul style="list-style-type: none"> • 800 mA input current when VIN = 7 V • 450 mA input current when 7 V < VIN < 9 V • 300 mA input current when 9 V < VIN < 10 V • Less than 300 mA input current when 10 V < VIN
5V	CN4 pin 4	4.75 to 5.25 V	500 mA	ST-LINK not powered
3V3	CN4 pin 14	3.0 to 3.6 V	-	ST-LINK not powered and SB13 must be OFF.

VIN or 5V power supply

When powered from VIN or 5V, it is still possible to use ST-LINK for communication for programming or debugging only, but it is mandatory to power the board first, using VIN or 5V, then to connect the USB cable to the PC. In this way, the enumeration always succeeds, thanks to the external power source.

The following power sequence procedure must be respected:

1. Check that SB1 is OFF
2. Connect the external power source to VIN or 5V
3. Power on the external power supply 7 V < VIN < 12 V to VIN, or 5V
4. Check red LED LD2 is turned ON
5. Connect the PC to USB connector CN1

If this order is not respected, the board may be powered by V_{BUS} first, then by VIN or 5V, and the following risks may be encountered:

1. If more than 300 mA current is needed by the board, the PC may be damaged or current supplied is limited by the PC. As a consequence, the board is not powered correctly.
2. 300 mA is requested at enumeration (since SB1 must be off) so there is the risk that the request is rejected and the enumeration does not succeed if the PC cannot provide such current. Consequently, the board is not power supplied (LED LD2 remains OFF).

3V3 power supply

When the board is powered by 3V3 (CN4 pin 14), the solder bridge SB13 must be OFF.

Using the 3V3 (CN4 pin 14) directly as power input can be interesting, for instance, in case the 3.3 V is provided by a shield board. In this case, the ST-LINK is not powered, thus programming and debugging features are not available.

In addition, to ensure powering the MCU, JP1 must be set to position [1-2].

6.4.3 External Power supply output

When powered by USB or VIN, the 5V (CN4 pin 4) can be used as an output power supply for an ARDUINO® Nano shield. In this case, the maximum current of the power source specified in [Table 5. External power sources](#) must be respected.

The 3.3V (CN4 pin 14) can be used also as a power supply output. The current is limited by the maximum current capability of the regulator U7 (500 mA max).

6.4.4 MCU power selection

JP1, VDD choice, selects the power supply of MCU in 3V3 or 5V:

- 3V3: Connect the jumper between pin 1 and 2 of JP1
- 5V: Connect the jumper between pin 2 and 3 of JP1

It is possible to measure the STM32 microcontroller consumption by removing the jumper and connecting an ammeter:

- Ammeter connected between [1-2]: power consumption measurement for VDD= 3V3
- Ammeter connected between [2-3]: power consumption measurement for VDD= 5V

6.5 LEDs

The tricolor LED (green, orange, red) LD1 (COM) provides information about ST-LINK communication status. The LD1 default color is red. LD1 turns to green to indicate that the communication is in progress between the PC and the ST-LINK/V2-1, with the following setup:

- Slow blinking red/OFF: at power-on before USB initialization
- Fast blinking red/OFF: after the first correct communication between PC and ST-LINK/V2-1 (enumeration)
- Red ON: when initialization between PC and ST-LINK/V2-1 is completed
- Green ON: after a successful target communication initialization
- Blinking red/green: during communication with the target
- Green ON: communication finished and successful
- Orange ON: communication failure

User LD3: The green LED is a user LED connected to the CN4 connector pin 15 (D13).

- When the I/O is HIGH value, the LED is ON
- When the I/O is LOW, the LED is OFF

PWR LD2: the red LED indicates that the STM8 part is powered and 5V power is available.

Default LD4: the red LED is a default LED connected to U2. It indicates that the current has exceeded the expected limit.

6.6 Push-button

B1 RESET: the push-button is connected to NRST, and it is used to reset the STM8.

6.7 UART Virtual communication

Thanks to SB3 and SB4, the UART interface of STM8 available on PD5 (TX) and PD6 (RX), can be connected to ST-LINK/V2-1. When UART Virtual communication is not used it is possible to use PD5/PD6 on ARDUINO® CN3 pins D1/D0. Refer to [Table 6](#).

Table 6. Virtual communication configuration

Solder bridge	State ⁽¹⁾	Description
SB3	ON	UART virtual communication enabled
	OFF	No UART virtual communication
SB4	ON	UART virtual communication enabled
	OFF	No UART virtual communication

1. The default configuration is reported in bold style.

6.8 Solder bridge configuration

Table 7 details the solder bridges of the STM8 Nucleo-32 board.

Table 7. Solder bridge configuration

Bridge	Setting ⁽¹⁾	Description
SB1	ON	USB power through CN1 allowed (100 mA max)
	OFF	USB power through CN1 allowed (300 mA max)
SB2	ON	STM8 forced in a Reset mode
	OFF	STM8 not forced in a Reset mode (standard operation)
SB3, SB4 (ST-LINK-UART)	ON	PA2 and PA3 on STM32F103CBT6 (ST-LINK MCU) are connected respectively to PD5 and PD6 on STM8 to have UART virtual communication enabled. Thus SB7 and SB9 must be OFF.
	OFF	PA2 and PA3 on STM32F103CBT6 (ST-LINK MCU) are disconnected from respectively PD5 and PD6 on STM8. PD5 and PD6 can be used as GPIO on Arduino connector CN4.
SB5	ON	MCO on STM32F103CBT6 (ST-LINK MCU) is connected to PA1 on STM8.
	OFF	MCO on STM32F103CBT6 (ST-LINK MCU) is disconnected from PA1 on STM8.
SB6	ON	GND is connected to AGND.
	OFF	GND is not connected to AGND.
SB7, SB9	ON	T_VCP_TX and T_VCP_RX are connected to CN3.
	OFF	T_VCP_TX and T_VCP_RX are disconnected from CN3.
SB8	ON	STM8 PD7 is connected to CN4 pin 5 for TLI support on ARDUINO® Nano A7.
	OFF	STM8 PD7 is disconnected to CN4 pin 5 for TLI support on ARDUINO® Nano A7.
SB10	ON	STM8 PF4 is connected to CN4 pin 5 for AI12 support on ARDUINO® Nano A7.
	OFF	STM8 PF4 is disconnected from CN4 pin 5 for AI12 support on ARDUINO® Nano A7.
SB11	ON	STM8 PF4 is connected to CN4 pin 6 for AI12 support on ARDUINO® Nano A6.
	OFF	STM8 PF4 is disconnected from CN4 pin 6 for AI12 support on ARDUINO® Nano A6.
SB12	ON	STM8 PD7 is connected to CN4 pin 6 for TLI support on ARDUINO® Nano A6.
	OFF	STM8 PD7 is disconnected from CN4 pin 6 for TLI support on ARDUINO® Nano A6.
SB13	ON	Output of voltage regulator LD39050PU33R is connected to 3.3V.
	OFF	Output of voltage regulator LD39050PU33R is not connected.

1. The default configuration is reported in bold style.

6.9 ARDUINO® Nano connectors

CN3 and CN4 are male connectors compatible with ARDUINO® Nano standard. Most shields designed for ARDUINO® Nano can fit the STM8 Nucleo-32 board

Caution: The STM8 I/Os are 3.3 V compatible instead of 5 V for ARDUINO® Nano.

Figure 8. ARDUINO® Nano connectors

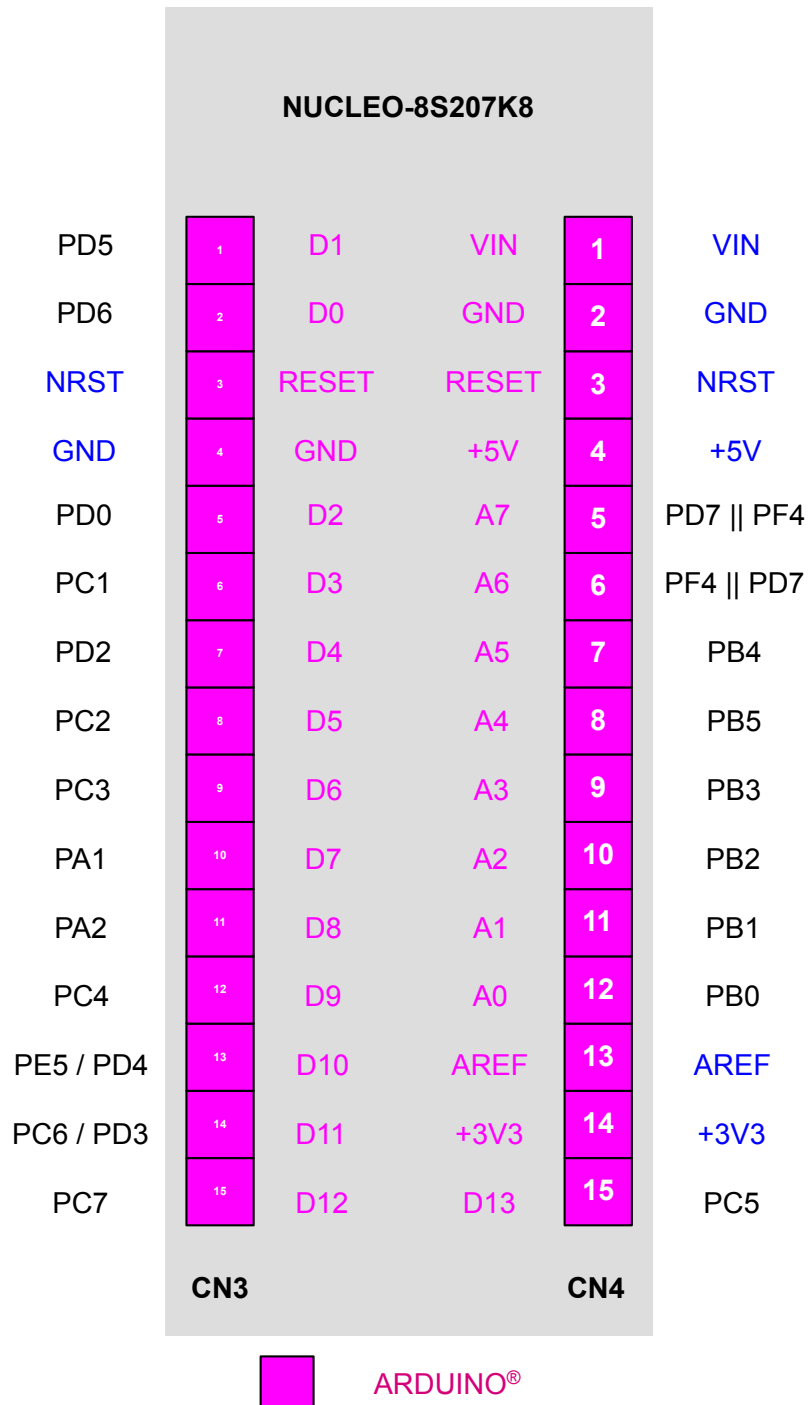

Table 8 shows the ARDUINO® Nano connector pin assignment on the STM8 Nucleo-32 board.

Table 8. ARDUINO® Nano connectors on the STM8 Nucleo-32 board

Connector	Pin number	Pin name	STM8 pin	Function
Left connector				
CN3	1	D1	PD5	UART3_TX ⁽¹⁾⁽²⁾
	2	D0	PD6	UART_RX ⁽¹⁾⁽²⁾
	3	RESET	NRST	RESET
	4	GND	-	Ground
	5	D2	PD0	TIM3_CH2
	6	D3	PC1	TIM1_CH1
	7	D4	PD2	TIM3_CH1
	8	D5	PC2	TIM1_CH2
	9	D6	PC3	TIM1_CH3
	10	D7	PA1	-
	11	D8	PA2	-
	12	D9	PC4	TIM1_CH4
	13	D10	PE5 / PD4	SPI_NSS / TIM2_CH1
	14	D11	PC6 / PD3	SPI_MOSI / TIM2_CH2
	15	D12	PC7	SPI_MISO
Right connector				
CN4	1	VIN	-	Power input
	2	GND	-	Ground
	3	RESET	NRST	RESET
	4	+5V	-	-
	5	A7	PD7 PF4	TLI Analog input 12 ⁽¹⁾
	6	A6	PF4 PD7	Analog input 12 TLI
	7	A5	PB4	Analog input 4 I2C_SCL
	8	A4	PB5	Analog input 5 I2C_SDA
	9	A3	PB3	Analog input 3
	10	A2	PB2	Analog input 2
	11	A1	PB1	Analog input 1
	12	A0	PB0	Analog input 0
	13	AREF	-	VDDA
	14	+3V3	-	3.3 V I/O
	15	D13	PC5	SPI clock

1. SB not fitted

2. In order not to have any conflict on the VCP signals (PD5 and PD6) when SB7 and SB9 are ON, SB3 and SB4 of ST-LINK must be OFF. Conversely for the other case.

7 Federal Communications Commission (FCC) and Industry Canada (IC) Compliance Statements

7.1 FCC Compliance Statement

Part 15.19

This device complies with Part 15 of the FCC Rules. Operation is subject to the following two conditions: (1) this device may not cause harmful interference, and (2) this device must accept any interference received, including interference that may cause undesired operation.

Part 15.21

Any changes or modifications to this equipment not expressly approved by STMicroelectronics may cause harmful interference and void the user's authority to operate this equipment.

Part 15.105

This equipment has been tested and found to comply with the limits for a Class A digital device, pursuant to part 15 of the FCC Rules. These limits are designed to provide reasonable protection against harmful interference when the equipment is operated in a commercial environment. This equipment generates, uses, and can radiate radio frequency energy and, if not installed and used in accordance with the instruction manual, may cause harmful interference to radio communications. Operation of this equipment in a residential area is likely to cause harmful interference in which case the user will be required to correct the interference at his own expense.

Responsible party (in the USA)

Terry Blanchard
Americas Region Legal | Group Vice President and Regional Legal Counsel, The Americas
STMicroelectronics, Inc.
750 Canyon Drive | Suite 300 | Coppel, Texas 75019
USA
Telephone: +1 972-466-7845

7.2 IC Compliance Statement

Industry Canada ICES-003 Compliance Label: CAN ICES-3 (A) / NMB-3 (A).

8 CE conformity

8.1 Warning

EN 55032 / CISPR32 (2012) Class A product

Warning: this device is compliant with Class A of EN55032 / CISPR32. In a residential environment, this equipment may cause radio interference.

Avertissement : cet équipement est conforme à la Classe A de la EN55032 / CISPR 32. Dans un environnement résidentiel, cet équipement peut créer des interférences radio.

Revision history

Table 9. Document revision history

Date	Version	Changes
14-Nov-2019	1	Initial release

Contents

1	Features	2
2	Ordering information	3
2.1	Product marking	3
2.2	Codification	3
3	Development environment	4
3.1	System requirements	4
3.2	Development toolchains	4
3.3	Demonstration software	4
4	Conventions	5
5	Quick start	6
5.1	Getting started	6
6	Hardware layout and configuration	7
6.1	STM8 Nucleo-32 board layout	7
6.2	Mechanical drawing	9
6.3	Embedded ST-LINK/V2-1	11
6.3.1	Drivers	11
6.3.2	ST-LINK/V2-1 firmware upgrade	11
6.4	Power supply and power selection	12
6.4.1	Power supply input from the USB connector	12
6.4.2	External Power supply inputs	13
6.4.3	External Power supply output	13
6.4.4	MCU power selection	13
6.5	LEDs	14
6.6	Push-button	14
6.7	UART Virtual communication	14
6.8	Solder bridge configuration	15
6.9	ARDUINO® Nano connectors	15
7	Federal Communications Commission (FCC) and Industry Canada (IC) Compliance Statements	18

7.1	FCC Compliance Statement	18
7.2	IC Compliance Statement	18
8	CE conformity	19
8.1	Warning	19
	Revision history	20
	Contents	21
	List of tables	23
	List of figures.....	24

List of tables

Table 1.	Ordering information	3
Table 2.	Codification explanation	3
Table 3.	ON/OFF convention	5
Table 4.	SB1 configuration	12
Table 5.	External power sources	13
Table 6.	Virtual communication configuration	14
Table 7.	Solder bridge configuration	15
Table 8.	ARDUINO® Nano connectors on the STM8 Nucleo-32 board	17
Table 9.	Document revision history	20

List of figures

Figure 1.	NUCLEO-8S207K8 top view	1
Figure 2.	NUCLEO-8S207K8 bottom view	1
Figure 3.	Hardware block diagram	7
Figure 4.	STM8 Nucleo-32 board top layout	8
Figure 5.	STM8 Nucleo-32 board bottom layout	9
Figure 6.	STM8 Nucleo-32 board mechanical drawing (in millimeter)	10
Figure 7.	USB composite device.	11
Figure 8.	ARDUINO® Nano connectors	16

IMPORTANT NOTICE – PLEASE READ CAREFULLY

STMicroelectronics NV and its subsidiaries (“ST”) reserve the right to make changes, corrections, enhancements, modifications, and improvements to ST products and/or to this document at any time without notice. Purchasers should obtain the latest relevant information on ST products before placing orders. ST products are sold pursuant to ST’s terms and conditions of sale in place at the time of order acknowledgement.

Purchasers are solely responsible for the choice, selection, and use of ST products and ST assumes no liability for application assistance or the design of Purchasers’ products.

No license, express or implied, to any intellectual property right is granted by ST herein.

Resale of ST products with provisions different from the information set forth herein shall void any warranty granted by ST for such product.

ST and the ST logo are trademarks of ST. For additional information about ST trademarks, please refer to www.st.com/trademarks. All other product or service names are the property of their respective owners.

Information in this document supersedes and replaces information previously supplied in any prior versions of this document.

© 2019 STMicroelectronics – All rights reserved