



# VD55G4

## Ultralow-power 800x700 monochrome sensor for always-on use



Bring intelligent always-on sensing to your smart devices with a discreet, ultralow-power monochrome global shutter image sensor

Designed for discreet integration in smart devices, the **VD55G4** is an ultralow-power monochrome global shutter CMOS image sensor with strong performance from visible light to near-infrared. Ideal for compact, power-conscious always-on applications, it enables reliable sensing, improved scene visibility, and extended operating time without compromising design freedom.

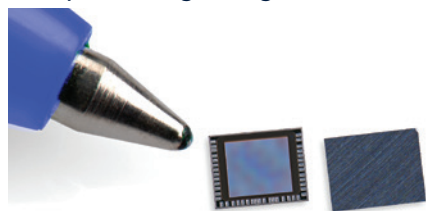

### KEY FEATURES

- Interface options:
  - MIPI CSI-2
  - MIPI I3C
  - SPI
- On-chip image processing:
  - Auto-exposure
  - Noise reduction
  - HDR
  - Defect & gamma correction
- Power saving features:
  - Low-power mode
  - Auto-wake up
- Data optimization:
  - Background removal
  - Image difference
  - Image statistics

### KEY APPLICATIONS

- Smart home appliances
- Biometrics
- Barcode scanning
- Wearables
- AI smart glasses
- XR/AR/VR headsets
- Medical devices
- Security cameras
- IoT vision nodes
- Edge AI devices
- Smart buildings

## VD55G4 at a glance

### Ultralow power

Featuring a low-power mode and optimized architecture, the VD55G4 helps extend battery life in compact devices while enabling fast autoexposure and efficient operation even at high frame rates. It typically consumes about 35 mW in operating mode and 1–2 mW in Auto-Wake-Up mode, helping reduce system-level power by keeping the SoC from processing data continuously. The sensor remains in an ultralow-power sleep state until needed, then automatically switches to full streaming mode.

### Versatile interfaces

With MIPI CSI-2, MIPI I3C, and SPI, the VD55G4 offers flexible connectivity for both vision SoCs and microcontroller-based designs. MIPI CSI-2 supports high frame rates of up to 184 fps, enabling highly responsive processing for vision SoCs. For compact, low-power MCU-based systems, MIPI I3C and SPI provide simple 2- to 4-wire connectivity that helps optimize board design and streamline integration.

### Capture with confidence

With high sensitivity from visible light to near-infrared, the VD55G4 delivers reliable monochrome capture in compact systems, from wearables to biometric devices. Its global shutter architecture, MCU-friendly interfaces, and on-chip image processing simplify integration. A complete ecosystem of boards, modules, software, drivers, and SDKs helps accelerate prototyping and implementation. A color version is also available as the **VD65G4**.

## Block diagram

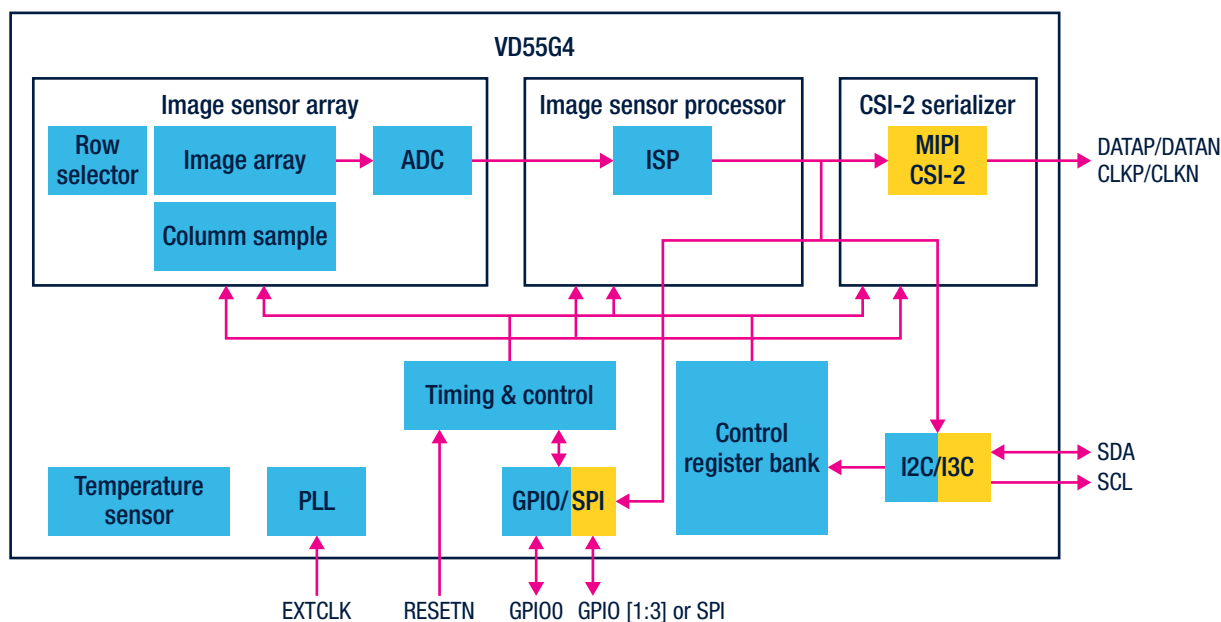

## Device summary

Category	Deliverable	Item	Description	Part number
Products	Sensor	VD55G4	800x700 monochrome sensor, bare die in reconstructed wafer	<a href="#">VD55G4CCCO/RW</a>
Evaluation Tools	Evaluation camera module	CAM-55G4 promodules	Promodule, VD55G4 sensor, 80° DFOV lens, clear filter	Soon available for online purchase
			Promodule, VD55G4 sensor, 160° DFOV lens, clear filter	
	Evaluation board	VD55G4 S-Board	VD55G4 sensor evaluation board with M12 holder, lens, and MIPI CSI-2/I3C/SPI output	
		P-Board	Generic evaluation board for any promodule with MIPI CSI-2 output	<a href="#">STEVAL-CAM-M01</a>
		EVK Main	Generic evaluation board for connecting any S-Board or promodule to computer with USB3 output	<a href="#">STEVAL-EVK-U01</a>



© STMicroelectronics - April 2026 - Printed in the United Kingdom - All rights reserved  
 ST and the ST logo are registered and/or unregistered trademarks of STMicroelectronics International NV or its affiliates in the EU and/or elsewhere. In particular, ST and the ST logo are Registered in the US Patent and Trademark Office.  
 For additional information about ST trademarks, please refer to [www.st.com/trademarks](http://www.st.com/trademarks).  
 All other product or service names are the property of their respective owners.

