

STCH03

Ultra-Low Standby Power Supplies



A compact quasi-resonant PWM controller specifically designed for ultra-low standby power supplies

Its built-in HV start-up circuit with zero power consumption, fully integrated blocks for primary-side constant-current output regulation and advanced power management make the STCH03 the best choice for high-efficiency and ultra-low standby consumption power supplies with excellent dynamic performance.

Designed to provide a constant output current (CC) regulation using primary-sensing feedback, the STCH03 reduces BOM costs and simplifies your design as a dedicated current reference IC and current sensor are no longer required.

Moreover, an embedded frequency jitter technique helps reduce EMI noise.

KEY FEATURES

- Advanced power management for ultra-low standby power consumption (under 10 mW at 230 V_{AC})
- 650 V embedded HV start-up circuit with zero power consumption
- Quasi-resonant (QR) zero-voltage switching (ZVS) operation
- Fully integrated primary-side constant-current output regulation (CC)
- Accurate and adjustable output OVP with auto-restart (STCH03) or latched (STCH03L) after fault
- Input voltage feed-forward compensation for mains-independent CC regulation
- Output under-voltage protection (UVP) with auto-restart

KEY APPLICATIONS

- Power supplies (from 15 to 60 W and higher) with ultra-low standby
- AC-DC chargers for smartphones, tablets, camcorders and other handheld equipment
- AC/DC adapters for set-top boxes, notebooks and auxiliary power supplies

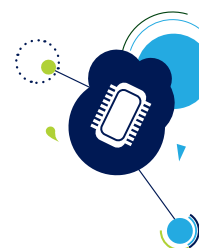

OFFLINE QUASI-RESONANT PWM CONTROLLER FOR ULTRA-LOW STANDBY POWER SUPPLIES

The STCH03 is an offline PWM controller designed for quasi resonant ZVS (zero voltage switching at switch turn-on) flyback converters, able to work in CC/CV mode (constant current / constant voltage). The CC mode of operation is useful in charger applications or as a short-circuit protection in power supplies. It combines a high-performance low-voltage PWM controller chip and a 650 V HV start-up cell in the same package.

The device features a unique characteristic: it is capable to provide a constant output current (CC) regulation using primary-sensing feedback. This eliminates the need for a dedicated current reference IC, as well as the current sensor, still maintaining a quite accurate output current regulation. The quasi-resonant operation is achieved by means of a transformer demagnetization sensing input that triggers MOSFET's turn-on, connected on the ZCD pin. This

input also monitors the output voltage to ensure a mains independent CC regulation (line voltage feed-forward control). The maximum switching frequency is top-limited below 167 kHz, so that at medium-light load a special function automatically lowers the operating frequency while still maintaining the operation as close to ZVS as possible. At very light-load, the device enters a controlled burst mode that helps minimize the residual input consumption.

TYPICAL APPLICATION DIAGRAM

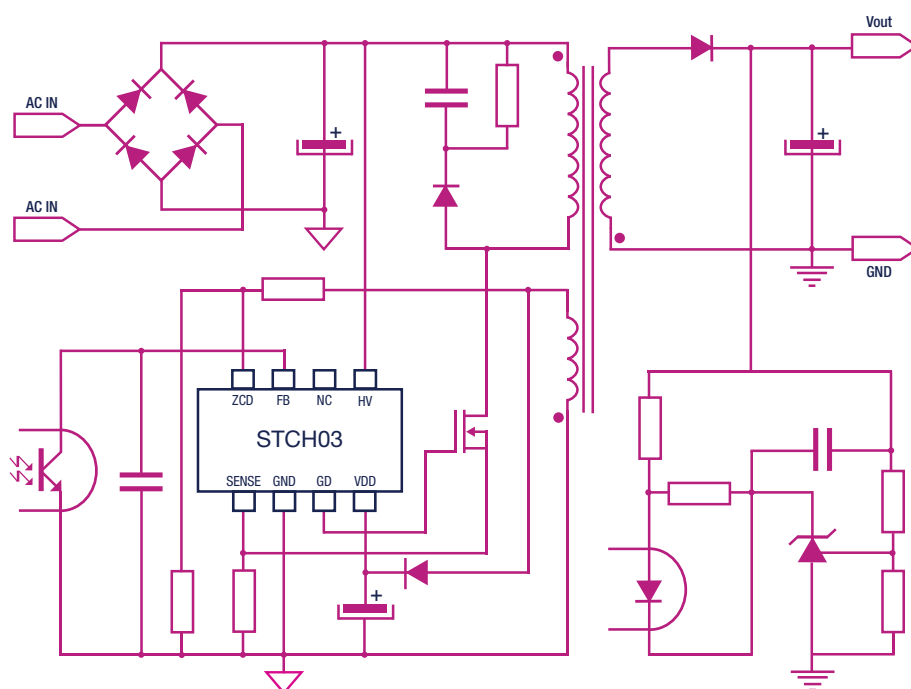

DEVICE SUMMARY

Order code	Package	Packing	Description
STCH03/STCH03TR	S08	Tube / Tape & Reel	Off-line PWM controller with auto-restart OVP
STCH03L/STCH03LTR	S08	Tube / Tape & Reel	Off-line PWM controller with latched OVP

DEVELOPMENT ENVIRONMENT

Order code	Description
STEVAL-SMACH15V1	15 W wide input range with CC primary sensing USB adapter
STEVAL-USBPD45C	45W USB-typeC PD adapter with Synchronous Rectification



© STMicroelectronics - June 2018 - Printed in United Kingdom - All rights reserved
The STMicroelectronics corporate logo is a registered trademark of the STMicroelectronics group of companies
All other names are the property of their respective owners

