

## N-channel 650 V, 1 $\Omega$ typ., 6.4 A SuperMESH Power MOSFET in a TO-220 and TO-220FP packages

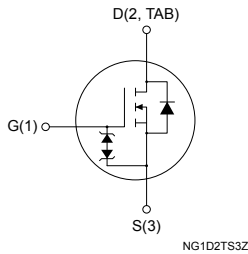
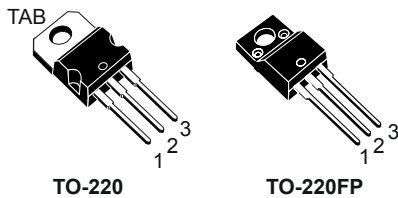

### Features

Order code	$V_{DS}$	$R_{DS(on)}$ max.	$I_D$
STP9NK65Z	650 V	1.2 $\Omega$	6.4 A
STP9NK65ZFP			

- 100% avalanche tested
- Gate charge minimized
- Very low intrinsic capacitance
- Zener-protected

### Applications

- Switching applications

### Description

These high-voltage devices are Zener-protected N-channel Power MOSFETs developed using the SuperMESH technology by STMicroelectronics, an optimization of the well-established PowerMESH. In addition to a significant reduction in on-resistance, these devices are designed to ensure a high level of dv/dt capability for the most demanding applications.

#### Product status links

[STP9NK65Z](#)

[STP9NK65ZFP](#)

#### Product summary

Order code	STP9NK65Z
Marking	P9NK65Z
Package	TO-220
Packing	Tube
Order code	STP9NK65ZFP
Marking	P9NK65ZFP
Package	TO-220FP
Packing	Tube

# 1 Electrical ratings

**Table 1. Absolute maximum ratings**

Symbol	Parameter	Value		Unit
		TO-220	TO-220FP	
$V_{DS}$	Drain-source voltage	650		V
$V_{GS}$	Gate-source voltage	±30		V
$I_D$	Drain current (continuous) at $T_C = 25\text{ °C}$	6.4	6.4 <sup>(1)</sup>	A
	Drain current (continuous) at $T_C = 100\text{ °C}$	4	4 <sup>(1)</sup>	
$I_{DM}^{(2)}$	Drain current (pulsed)	25.6	25.6 <sup>(1)</sup>	A
$P_{TOT}$	Total power dissipation at $T_C = 25\text{ °C}$	125	30	W
ESD	Gate-source human body model (C = 100 pF, R = 1.5 kΩ)	4		kV
$dv/dt^{(3)}$	Peak diode recovery voltage slope	4.5		V/ns
$V_{ISO}$	Insulation withstand voltage (RMS) from all three leads to external heat sink (t = 1 s; $T_C = 25\text{ °C}$ )	-	2.5	kV
$T_{stg}$	Storage temperature range	-55 to 150		°C
$T_J$	Operating junction temperature range			

1. Limited by maximum junction temperature.

2. Pulse width limited by safe operating area.

3.  $I_{SD} \leq 6.4\text{ A}$ ,  $di/dt \leq 200\text{ A}/\mu\text{s}$ ,  $V_{DD} = 520\text{ V}$ .

**Table 2. Thermal data**

Symbol	Parameter	Value		Unit
		TO-220	TO-220FP	
$R_{thJC}$	Thermal resistance, junction-to-case	1	4.2	°C/W
$R_{thJA}$	Thermal resistance, junction-to-ambient	62.5		°C/W

**Table 3. Avalanche characteristics**

Symbol	Parameter	Value	Unit
$I_{AR}$	Avalanche current, repetitive or not-repetitive (pulse width limited by $T_J$ max.)	6.4	A
$E_{AS}$	Single pulse avalanche energy (starting $T_J = 25\text{ °C}$ , $I_D = I_{AR}$ , $V_{DD} = 50\text{ V}$ )	200	mJ

## 2 Electrical characteristics

$T_C = 25\text{ °C}$  unless otherwise specified.

**Table 4. On/off states**

Symbol	Parameter	Test condition	Min.	Typ.	Max.	Unit
$V_{(BR)DSS}$	Drain-source Breakdown voltage	$I_D = 1\text{ mA}$ , $V_{GS} = 0\text{ V}$	650	-	-	V
$I_{DSS}$	Zero gate voltage drain current	$V_{GS} = 0\text{ V}$ , $V_{DS} = 650\text{ V}$	-	-	1	$\mu\text{A}$
		$V_{GS} = 0\text{ V}$ , $V_{DS} = 650\text{ V}$ , $T_C = 125\text{ °C}^{(1)}$	-	-	50	
$I_{GSS}$	Gate-body leakage current	$V_{DS} = 0\text{ V}$ , $V_{GS} = \pm 20\text{ V}$	-	-	$\pm 10$	$\mu\text{A}$
$V_{GS(th)}$	Gate threshold voltage	$V_{DS} = V_{GS}$ , $I_D = 100\text{ }\mu\text{A}$	3	3.75	4.5	V
$R_{DS(on)}$	Static drain-source on-resistance	$V_{GS} = 10\text{ V}$ , $I_D = 3.2\text{ A}$	-	1	1.2	$\Omega$

1. Specified by design, not tested in production.

**Table 5. Dynamic**

Symbol	Parameter	Test condition	Min.	Typ.	Max.	Unit
$C_{iss}$	Input capacitance	$V_{DS} = 25\text{ V}$ , $f = 1\text{ MHz}$ , $V_{GS} = 0\text{ V}$	-	1145	-	pF
$C_{oss}$	Output capacitance		-	130	-	pF
$C_{riss}$	Reverse transfer capacitance		-	28	-	pF
$C_{oss\ eq.}^{(1)}$	Equivalent output capacitance	$V_{DS} = 0\text{ to }400\text{ V}$ , $V_{GS} = 0\text{ V}$	-	55	-	pF
$Q_g$	Total gate charge	$V_{DD} = 520\text{ V}$ , $I_D = 6.4\text{ A}$ , $V_{GS} = 0\text{ to }10\text{ V}$ (see the Figure 16. Test circuit for gate charge behavior)	-	41	-	nC
$Q_{gs}$	Gate-source charge		-	7.5	-	nC
$Q_{gd}$	Gate-drain charge		-	22	-	nC

1.  $C_{oss\ eq.}$  is defined as a constant equivalent capacitance giving the same charging time as  $C_{oss}$  when  $V_{DS}$  increases from 0 to 80%  $V_{DSS}$ .

**Table 6. Switching times**

Symbol	Parameter	Test condition	Min.	Typ.	Max.	Unit
$t_{d(on)}$	Turn-on delay time	$V_{DD} = 325\text{ V}$ , $I_D = 3.2\text{ A}$ , $R_G = 4.7\text{ }\Omega$ , $V_{GS} = 10\text{ V}$	-	20	-	ns
$t_r$	Rise time		-	12	-	ns
$t_{d(off)}$	Turn-off delay time	(see the Figure 15. Test circuit for resistive load switching times and Figure 20. Switching time waveform)	-	45	-	ns
$t_f$	Fall time		-	15	-	ns

**Table 7. Source drain diode**

Symbol	Parameter	Test condition	Min.	Typ.	Max.	Unit
$I_{SD}$	Source-drain current		-	-	6.4	A
$I_{SDM}^{(1)}$	Source-drain current (pulsed)		-	-	25.6	A
$V_{SD}^{(2)}$	Forward on voltage	$I_{SD} = 6.4 \text{ A}, V_{GS} = 0 \text{ V}$	-	-	1.6	V
$t_{rr}$	Reverse recovery time	$I_{SD} = 6.4 \text{ A}, di/dt = 100 \text{ A}/\mu\text{s},$	-	400	-	ns
$Q_{rr}$	Reverse recovery charge	$V_{DD} = 50 \text{ V}, T_J = 150 \text{ }^\circ\text{C}$	-	2.6	-	$\mu\text{C}$
$I_{RRM}$	Reverse recovery current	(see the Figure 17. Test circuit for inductive load switching and diode recovery times)	-	13	-	A

1. Pulse width is limited by safe operating area.
2. Pulsed: pulse duration = 300  $\mu\text{s}$ , duty cycle 1.5%.

## 2.1 Electrical characteristics curves

Figure 1. Safe operating area for TO-220

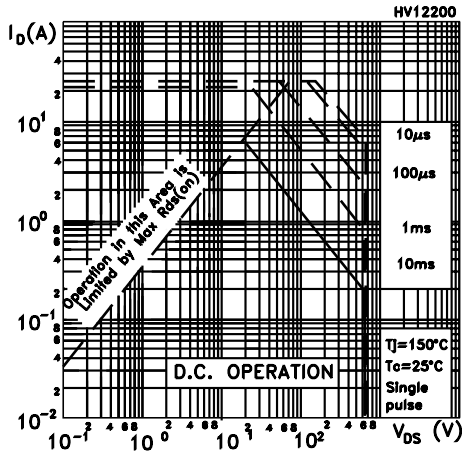

Figure 2. Normalized transient thermal impedance for TO-220

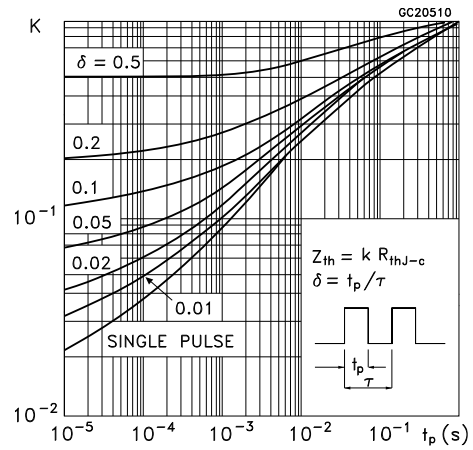

Figure 3. Safe operating area for TO-220FP

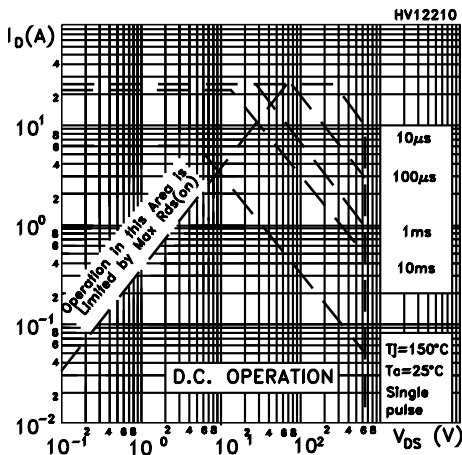

Figure 4. Normalized transient thermal impedance for TO-220FP

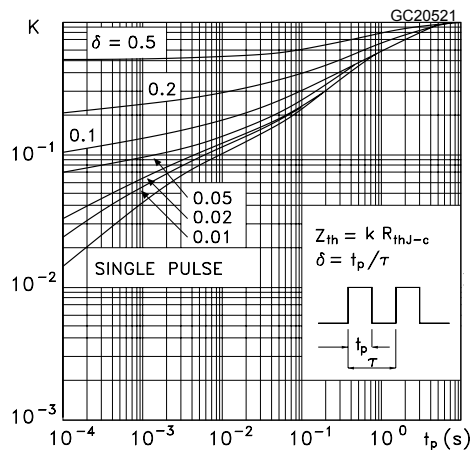

Figure 5. Typical output characteristics

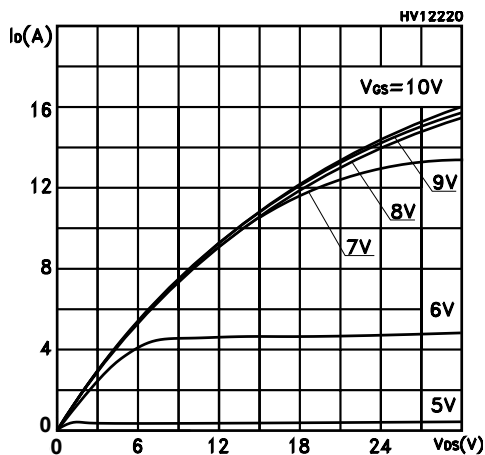

Figure 6. Typical transfer characteristics

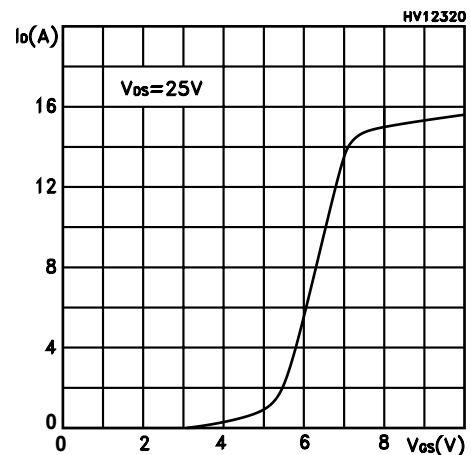

Figure 7. Typical static drain-source on-resistance

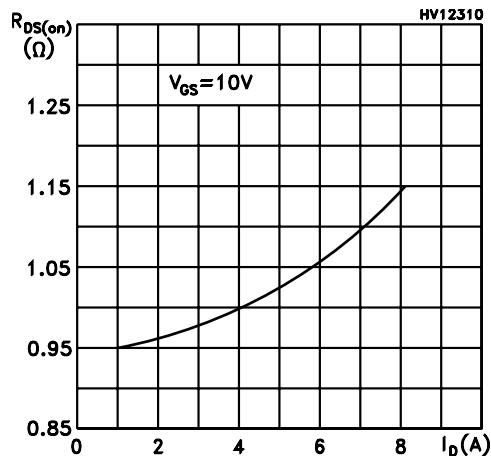

Figure 8. Typical gate charge characteristics

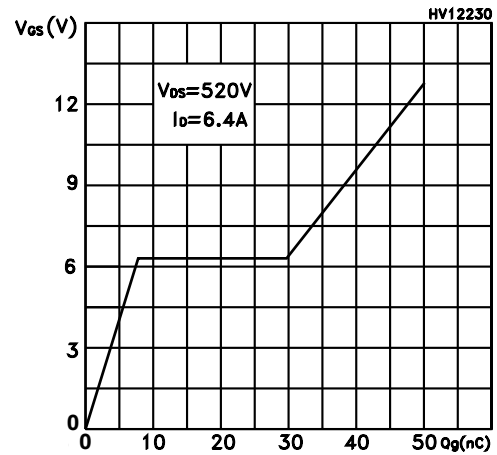

Figure 9. Typical capacitance variations

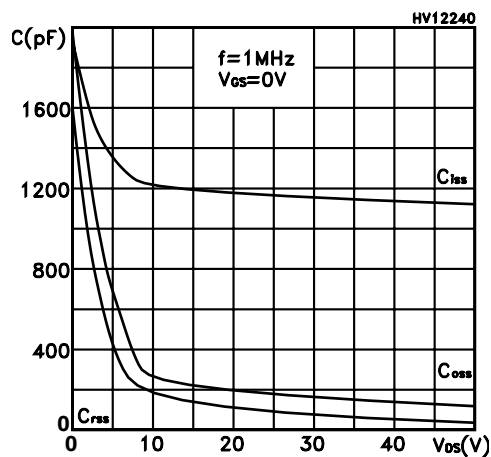

Figure 10. Normalized gate threshold vs temperature

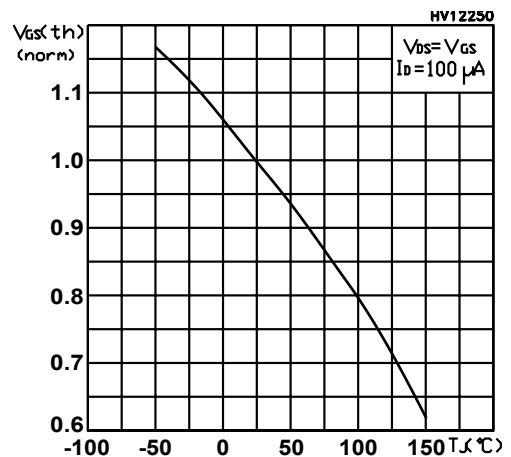

Figure 11. Normalized on-resistance vs temperature

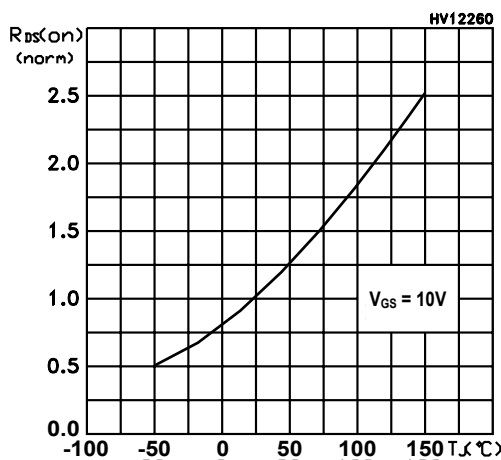

Figure 12. Typical reverse diode forward characteristics

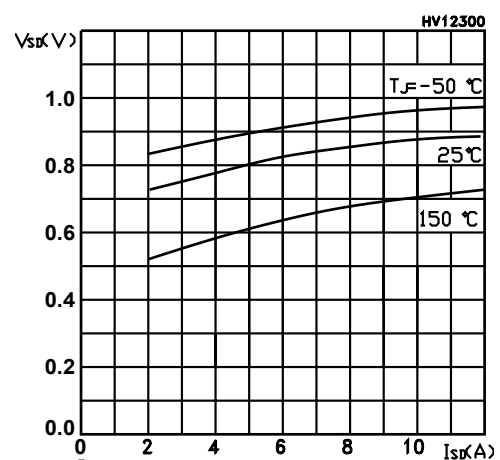

Figure 13. Normalized breakdown voltage vs temperature

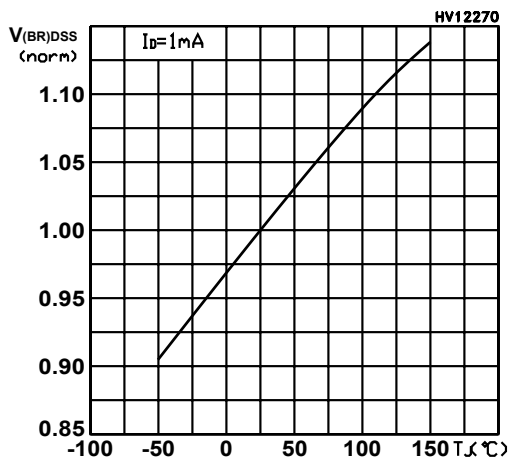
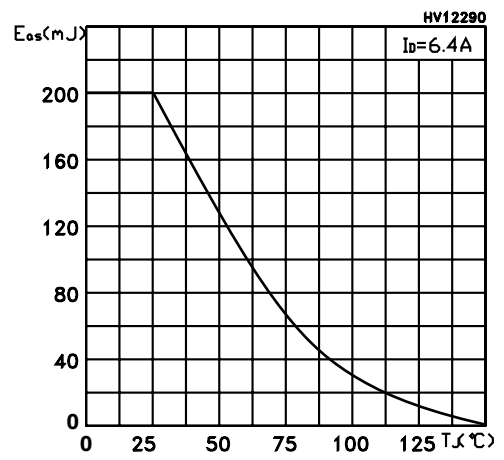
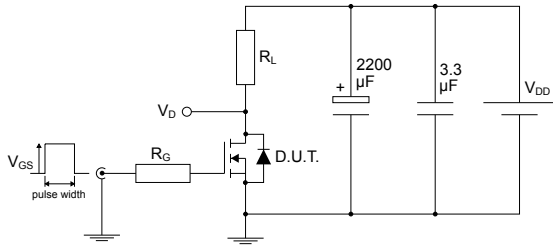

Figure 14. Maximum avalanche energy vs temperature



### 3 Test circuits

**Figure 15. Test circuit for resistive load switching times**

AM01468v1

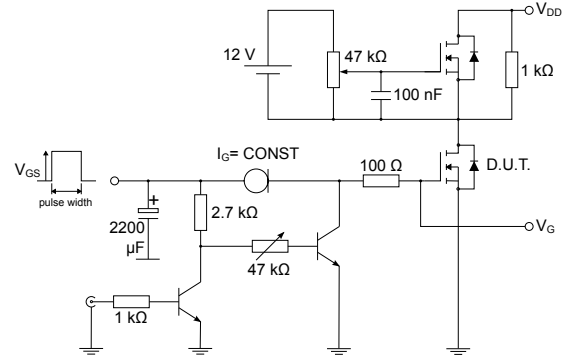
**Figure 16. Test circuit for gate charge behavior**

AM01469v1

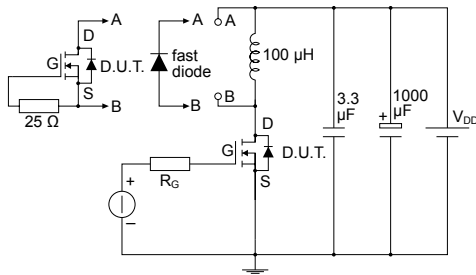
**Figure 17. Test circuit for inductive load switching and diode recovery times**

AM01470v1

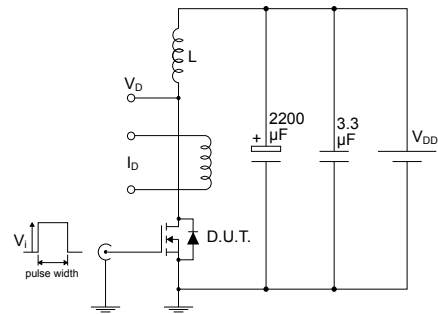
**Figure 18. Unclamped inductive load test circuit**

AM01471v1

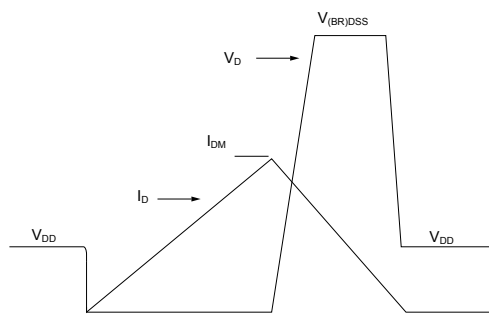
**Figure 19. Unclamped inductive waveform**

AM01472v1

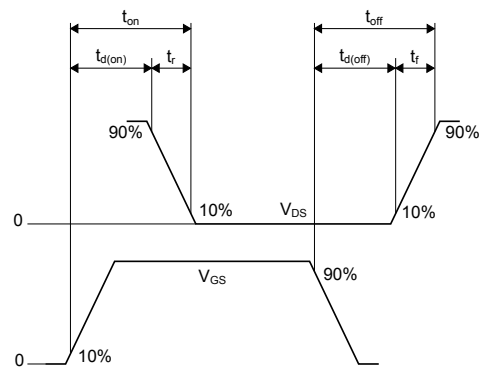
**Figure 20. Switching time waveform**

AM01473v1

## 4 Package information

To meet environmental requirements, ST offers these devices in different grades of **ECOPACK** packages, depending on their level of environmental compliance. ECOPACK specifications, grade definitions, and product status are available at: [www.st.com](http://www.st.com). ECOPACK is an ST trademark.

### 4.1 TO-220 type A package information

Figure 21. TO-220 type A package outline

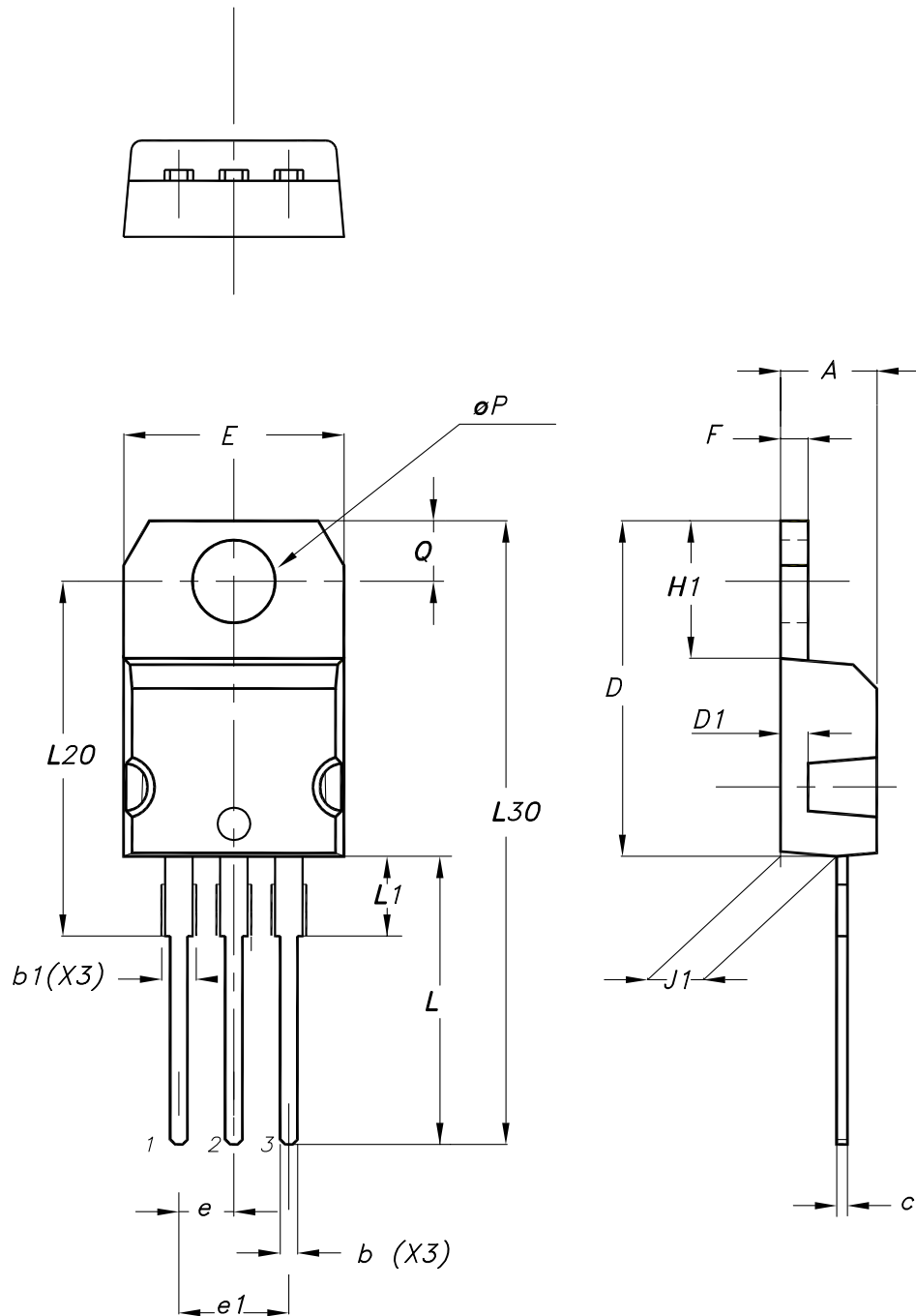

0015988\_typeA\_Rev\_24

Table 8. TO-220 type A package mechanical data

Dim.	mm		
	Min.	Typ.	Max.
A	4.40		4.60
b	0.61		0.88
b1	1.14		1.55
c	0.48		0.70
D	15.25		15.75
D1		1.27	
E	10.00		10.40
e	2.40		2.70
e1	4.95		5.15
F	1.23		1.32
H1	6.20		6.60
J1	2.40		2.72
L	13.00		14.00
L1	3.50		3.93
L20		16.40	
L30		28.90	
øP	3.75		3.85
Q	2.65		2.95
Slug flatness		0.03	0.10

## 4.2 TO-220FP type B package information

Figure 22. TO-220FP type B package outline

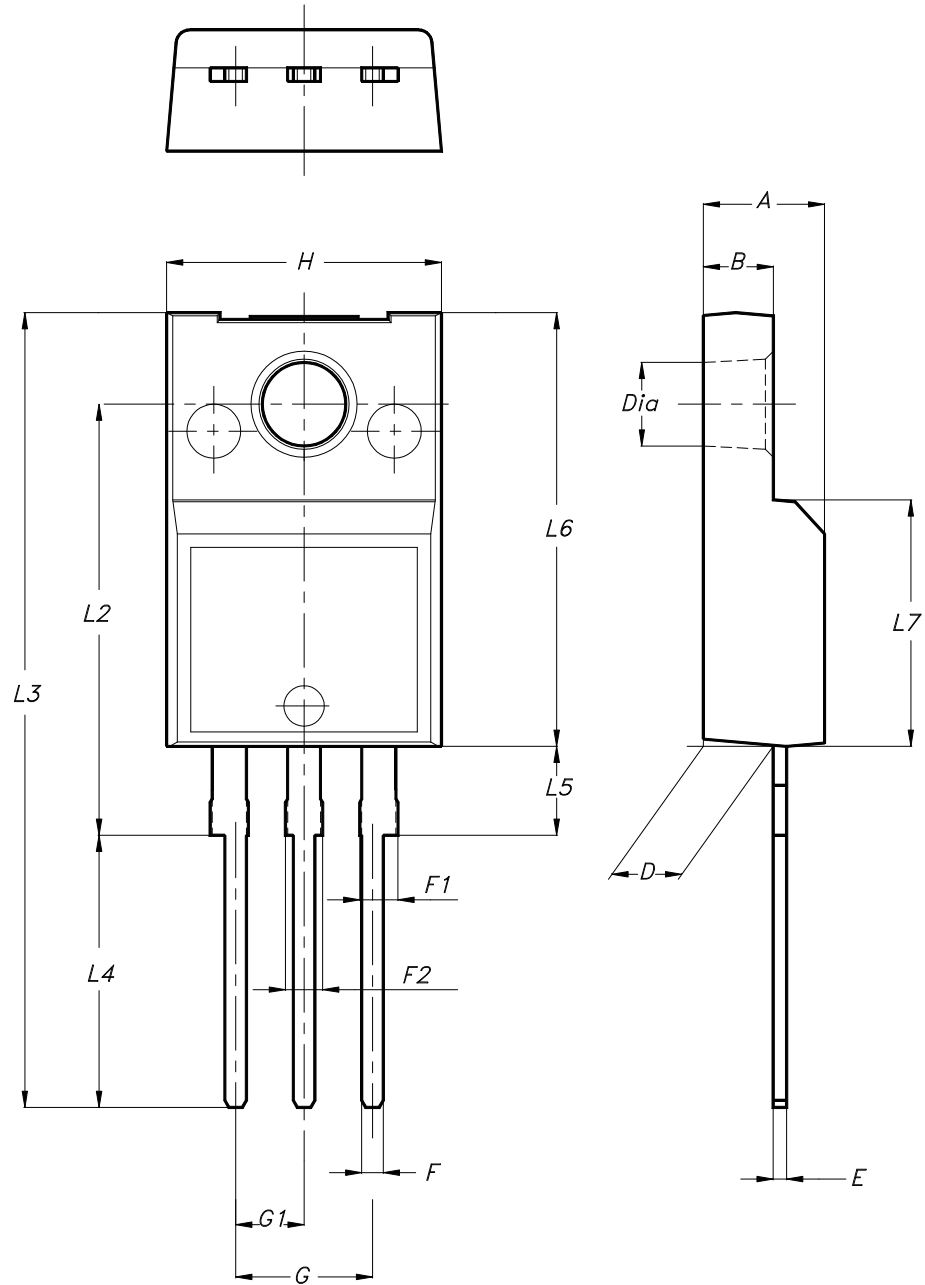

7012510\_B\_rev.14

Table 9. TO-220FP type B package mechanical data

Dim.	mm		
	Min.	Typ.	Max.
A	4.40		4.60
B	2.50		2.70
D	2.50		2.75
E	0.45		0.70
F	0.75		1.00
F1	1.15		1.70
F2	1.15		1.70
G	4.95		5.20
G1	2.40		2.70
H	10.00		10.40
L2		16.00	
L3	28.60		30.60
L4	9.80		10.60
L5	2.90		3.60
L6	15.90		16.40
L7	9.00		9.30
Dia	3.00		3.20

## Revision history

**Table 10. Document revision history**

Date	Version	Changes
11-Sep-2006	2	Complete version.
19-Dec-2007	3	The document has been reformatted.
26-Jan-2012	4	Modified: <i>Features</i> in cover page. Updated: <i>Section 4: Package mechanical data</i> . Minor text changes.
10-Feb-2026	5	Updated <a href="#">Section 4: Package information</a> . Minor text changes.



---

## Contents

<b>1</b>	<b>Electrical ratings</b> .....	<b>2</b>
<b>2</b>	<b>Electrical characteristics</b> .....	<b>3</b>
<b>2.1</b>	Electrical characteristics curves .....	<b>5</b>
<b>3</b>	<b>Test circuits</b> .....	<b>8</b>
<b>4</b>	<b>Package information</b> .....	<b>9</b>
<b>4.1</b>	TO-220 type A package information .....	<b>9</b>
<b>4.2</b>	TO-220FP type B package information .....	<b>11</b>
	<b>Revision history</b> .....	<b>13</b>

**IMPORTANT NOTICE – READ CAREFULLY**

STMicroelectronics NV and its subsidiaries (“ST”) reserve the right to make changes, corrections, enhancements, modifications, and improvements to ST products and/or to this document at any time without notice.

In the event of any conflict between the provisions of this document and the provisions of any contractual arrangement in force between the purchasers and ST, the provisions of such contractual arrangement shall prevail.

The purchasers should obtain the latest relevant information on ST products before placing orders. ST products are sold pursuant to ST’s terms and conditions of sale in place at the time of order acknowledgment.

The purchasers are solely responsible for the choice, selection, and use of ST products and ST assumes no liability for application assistance or the design of the purchasers’ products.

No license, express or implied, to any intellectual property right is granted by ST herein.

Resale of ST products with provisions different from the information set forth herein shall void any warranty granted by ST for such product.

If the purchasers identify an ST product that meets their functional and performance requirements but that is not designated for the purchasers’ market segment, the purchasers shall contact ST for more information.

ST and the ST logo are trademarks of ST. For additional information about ST trademarks, refer to [www.st.com/trademarks](http://www.st.com/trademarks). All other product or service names are the property of their respective owners.

Information in this document supersedes and replaces information previously supplied in any prior versions of this document.

© 2026 STMicroelectronics – All rights reserved