

Arm[®] Cortex[®]-M33 32-bit MCU, TrustZone[®], FPU, 1023 CoreMark[®],
250 MHz, 1-Mbyte flash memory, 304-Kbyte RAM

Datasheet - production data

Features

Includes ST state-of-the-art patented technology

Core

- Arm[®] Cortex[®]-M33 CPU with TrustZone[®], FPU, frequency up to 250 MHz, MPU, 1023 CoreMark[®]

ART Accelerator

- 8-Kbyte instruction cache for 0-wait-state execution from flash and external memories
- 4-Kbyte data cache for external memories

Benchmark

- 1023 CoreMark[®] (4.092 CoreMark[®]/MHz)

Memories

- Up to 1 Mbyte of embedded flash memory with ECC, two banks read-while-write
- Up to 48-Kbyte per bank with high-cycling capability (100 K cycles) for data flash
- 2-Kbyte OTP (one-time programmable)
- 304 Kbytes of SRAM (80-Kbyte SRAM2 with ECC)
- 2 Kbytes of backup SRAM available in the lowest power modes
- Flexible external memory controller with up to 16-bit: SRAM, PSRAM, SDRAM/LPDDR SDRAM, FRAM, NOR/NAND memories
- One Octo-SPI interface with support for serial PSRAM/NAND/NOR, hyper RAM/flash frame formats
- One SD/SDIO/MMC interface

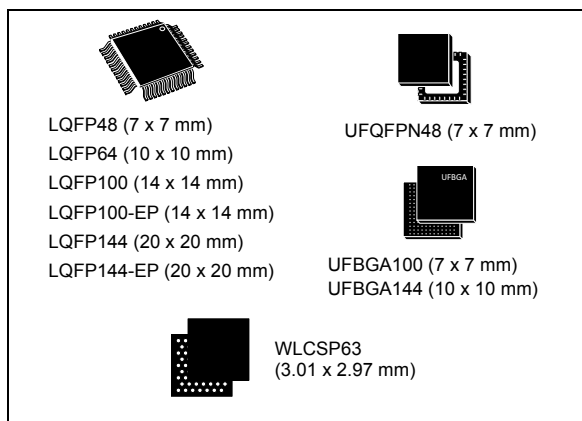

Clock management

- Internal oscillators: 64 MHz HSI, 48 MHz HSI48, 4 MHz CSI, 32 kHz LSI
- External oscillators: 4-50 MHz HSE, 32.768 kHz LSE

General-purpose inputs/outputs

- Up to 112 fast I/Os with interrupt capability (most of them 5 V-tolerant)
- Up to ten I/Os with independent supply down to 1.08 V

Low-power consumption

- Sleep, Stop, and Standby modes
- V_{BAT} supply for RTC, 32 backup registers (32-bit)

Security

- Arm[®] TrustZone[®] with Armv8-M mainline security extension
- Up to eight configurable SAU regions
- TrustZone[®] aware and securable peripherals
- Flexible life cycle scheme with secure debug authentication
- SFI (secure firmware installation)

- Root of trust thanks to unique boot entry and secure hide protection area (HDP)
- Secure firmware upgrade support with TF-M
- Public key accelerator, ECDSA signature verification
- HASH (SHA-1, SHA-2, SHA-3)
- True random number generator, NIST SP800-90B compliant
- 96-bit unique ID
- Active tampers

Two DMA controllers to offload the CPU

- Two dual-port DMAs with FIFO

Mathematical acceleration

- CORDIC for trigonometric functions acceleration

Reset and supply management

- 1.71 V to 3.6 V application supply and I/O
- POR, PDR, PVD, and BOR
- Embedded regulator with configurable scalable output to supply the digital circuitry

Up to 16 timers

- Ten 16-bit timers (including two low-power 16-bit timers available in Stop mode)
- Two 32-bit timers with up to four IC/OC/PWM or pulse counters and quadrature (incremental) encoder input
- Two watchdogs
- Two SysTick timers

Up to 23 communication interfaces

- Up to three I2Cs Fm+ (SMBus/PMBus®)
- Two I3Cs
- Up to eight U(S)ARTs (ISO7816 interface, LIN, IrDA, modem control) and one LPUART
- Up to four SPIs, including three muxed in full-duplex I2S audio class accuracy via internal audio PLL or external clock, and up to four additional SPIs from four USARTs when configured in Synchronous mode (one additional SPI with OctoSPI)
- Two FDCANs
- One HDMI-CEC
- Ethernet MAC interface with DMA controller
- One USB 2.0 full-speed host and device
- One USB Type-C®/USB Power Delivery r3.1
- Three 12-bit ADCs with up to 5 Msps in 12-bit
- One 12-bit DAC with two channels
- Digital temperature sensor
- Two ultra-low-power comparators

Programmable logic array (PLAY)

- PLAY interface with 128 inputs and 16 outputs

Debug

- Authenticated debug, flexible device life cycle
- Serial wire-debug (SWD), JTAG, Embedded Trace Macrocell™ (ETM)

Packages

- Exposed pad option available for industrial applications (selected packages)
- **ECOPACK2 compliant packages**

Table 1. Device summary

Reference	Part numbers
STM32H543xx	STM32H543CG, STM32H543RG, STM32H543VG, STM32H543UG, STM32H543ZG, STM32H543CE, STM32H543RE, STM32H543VE, STM32H543ZE

Contents

1	Introduction	13
2	Description	14
3	Functional overview	18
3.1	Arm Cortex-M33 core with TrustZone and FPU	18
3.2	ART Accelerator (ICACHE and DCACHE)	18
3.2.1	Instruction cache (ICACHE)	18
3.2.2	Data cache (DCACHE)	19
3.3	Memory protection unit	20
3.4	Embedded flash memory	20
3.4.1	FLASH security and protections	21
3.4.2	FLASH privilege protection	21
3.5	Embedded SRAMs	21
3.5.1	SRAMs TrustZone security	22
3.5.2	SRAMs privilege protection	22
3.6	Security overview	22
3.7	Boot modes	23
3.8	Global TrustZone controller (GTZC)	23
3.9	TrustZone security architecture	24
3.9.1	TrustZone peripheral classification	24
3.9.2	Default TrustZone security state	24
3.10	Power supply management	25
3.10.1	Power supply schemes	25
3.10.2	Startup with VCORE supplied by external source (Bypass)	28
3.10.3	Power supply supervisor	29
3.10.4	Reset mode	30
3.10.5	VBAT operation	30
3.10.6	PWR TrustZone security	30
3.11	Peripheral interconnect matrix	31
3.12	Reset and clock controller (RCC)	31
3.12.1	RCC TrustZone security	32
3.13	Clock recovery system (CRS)	32

- 3.14 General-purpose inputs/outputs (GPIOs) 32
 - 3.14.1 GPIOs TrustZone security 33
- 3.15 Multi-AHB bus matrix 33
- 3.16 General purpose direct memory access controller (GPDMA) 33
- 3.17 Programmable logic array (PLAY) 35
- 3.18 Interrupts and events 35
 - 3.18.1 Nested vectored interrupt controller (NVIC) 35
 - 3.18.2 Extended interrupt/event controller (EXTI) 35
- 3.19 Cyclic redundancy check calculation unit (CRC) 36
- 3.20 CORDIC coprocessor (CORDIC) 36
- 3.21 Flexible memory controller (FMC) 37
 - 3.21.1 LCD parallel interface 37
 - 3.21.2 FMC TrustZone security 37
- 3.22 Octo-SPI interface (OCTOSPI) 38
 - 3.22.1 OCTOSPI TrustZone security 38
- 3.23 Delay block (DLYB) 38
- 3.24 Analog-to-digital converters (ADC1, ADC2, and ADC3) 39
 - 3.24.1 Analog temperature sensor 39
 - 3.24.2 Internal voltage reference (VREFINT) 40
 - 3.24.3 VBAT battery voltage monitoring 40
- 3.25 Digital temperature sensor (DTS) 40
- 3.26 Digital to analog converter (DAC) 40
- 3.27 Voltage reference buffer (VREFBUF) 41
- 3.28 Comparators (COMP) 41
- 3.29 True random number generator (RNG) 41
- 3.30 HASH hardware accelerator (HASH) 42
- 3.31 Public key accelerator (PKA) 43
- 3.32 Timers and watchdogs 43
 - 3.32.1 Advanced-control timers (TIM1, TIM8) 44
 - 3.32.2 General-purpose timers (TIM2, TIM3, TIM4, TIM5, TIM15) 44
 - 3.32.3 Basic timers (TIM6, TIM7) 45
 - 3.32.4 Low-power timers (LPTIM1, LPTIM2) 45
 - 3.32.5 Independent watchdog (IWDG) 45
 - 3.32.6 Window watchdog (WWDG) 46
 - 3.32.7 SysTick timer 46

Prerelease product(s)

3.33	Real-time clock (RTC), tamper and backup registers	46
3.33.1	Real-time clock (RTC)	46
3.33.2	Tamper and backup registers (TAMP)	47
3.34	Inter-integrated circuit interface (I ² C)	48
3.35	Improved inter-integrated circuit (I3C)	49
3.36	Universal synchronous/asynchronous receiver transmitter (USART/UART) and low-power universal asynchronous receiver transmitter (LPUART)	50
3.36.1	Universal synchronous/asynchronous receiver transmitter (USART/UART)	51
3.36.2	Low-power universal asynchronous receiver transmitter (LPUART)	52
3.37	Serial peripheral interface (SPI) / inter-integrated sound interface (I2S)	54
3.38	Secure digital input/output and MultiMediaCards interface (SDMMC)	55
3.39	Controller area network (FDCAN)	56
3.40	USB full speed (USB)	57
3.41	USB Type-C/USB power delivery controller (UCPD)	57
3.42	Ethernet MAC interface with dedicated DMA controller (ETH)	58
3.43	High-definition multimedia interface (HDMI) - consumer electronics control (CEC)	58
3.44	Development support	59
3.44.1	Serial-wire/JTAG debug port (SWJ-DP)	59
3.44.2	Embedded Trace Macrocell	59
4	Pinout, pin description, and alternate functions	60
4.1	Pinout/ballout schematics	60
4.2	Pin description	67
4.3	Alternate functions	79
5	Electrical characteristics	93
5.1	Parameter conditions	93
5.1.1	Minimum and maximum values	93
5.1.2	Typical values	93
5.1.3	Typical curves	93
5.1.4	Loading capacitor	93
5.1.5	Pin input voltage	93
5.1.6	Power supply scheme	94

5.2 Absolute maximum ratings 95

5.3 Operating conditions 96

5.3.1 General operating conditions 96

5.3.2 VCAP external capacitor 100

5.3.3 Operating conditions at power-up/down 101

5.3.4 Embedded reset and power control block characteristics 101

5.3.5 Embedded reference voltage 103

5.3.6 Supply current characteristics 103

5.3.7 External clock source characteristics 114

5.3.8 Internal clock source characteristics 119

5.3.9 PLL characteristics 121

5.3.10 Memory characteristics 123

5.3.11 EMC characteristics 124

5.3.12 Absolute maximum ratings (electrical sensitivity) 126

5.3.13 I/O current injection characteristics 127

5.3.14 I/O port characteristics 127

5.3.15 NRST pin characteristics 141

5.3.16 Extended interrupt and event controller input (EXTI) characteristics .. 142

5.3.17 PLAY characteristics 142

5.3.18 FMC characteristics 144

5.3.19 Octo-SPI interface characteristics 164

5.3.20 Delay block (DLYB) characteristics 168

5.3.21 12-bit ADC characteristics 168

5.3.22 DAC characteristics 177

5.3.23 Analog temperature sensor characteristics 180

5.3.24 Digital temperature sensor characteristics 181

5.3.25 V_{CORE} monitoring characteristics 181

5.3.26 Temperature and V_{BAT} monitoring 182

5.3.27 Voltage booster for analog switch 182

5.3.28 V_{REFBUF} characteristics 183

5.3.29 Comparator characteristics 184

5.3.30 Timer characteristics 185

5.3.31 Low-power timer characteristics 186

5.3.32 Communication interfaces 186

6 Package information 204

6.1 Device marking 204

Prerelease product(s)

6.2	LQFP48 package information (5B)	205
6.3	UFQFPN48 package information (A0B9)	208
6.4	WLCSP63 package information (C02A)	210
6.5	LQFP64 package information (5W)	212
6.6	LQFP100 package information (1L)	215
6.7	LQFP100 package information (OS)	218
6.8	UFBGA100 package information (A0C2)	221
6.9	LQFP144 package information (1A)	224
6.10	LQFP144 package information (ZO)	227
6.11	UFBGA144 package information (A0Y2)	230
6.12	Package thermal characteristics	233
	6.12.1 Reference documents	234
7	Ordering information	235
8	Important security notice	236
9	Revision history	237

List of tables

Table 1.	Device summary	2
Table 2.	STM32H543xx features and peripheral counts	15
Table 3.	ADC features	39
Table 4.	Timer features.	43
Table 5.	I2C implementation.	48
Table 6.	I3C peripheral controller/target features versus MIPI v1.1	50
Table 7.	USART, UART and LPUART features	50
Table 8.	SPI features	55
Table 9.	SDMMC features	56
Table 10.	Legend/abbreviations used in the pinout table	67
Table 11.	STM32H543xx pin/ball definition	68
Table 12.	Alternate functions AF0 to AF7	79
Table 13.	Alternate functions AF8 to AF15	86
Table 14.	Voltage characteristics	95
Table 15.	Current characteristics	96
Table 16.	Thermal characteristics.	96
Table 17.	General operating conditions	96
Table 18.	Maximum allowed clock frequencies	99
Table 19.	Supply voltage and maximum frequency configuration	100
Table 20.	Operating conditions at power-up/down (regulator ON)	101
Table 21.	Embedded reset and power control block characteristics.	101
Table 22.	Embedded reference voltage	103
Table 23.	Internal reference voltage calibration value	103
Table 24.	Typical and maximum current consumption in Run mode, code with data processing running from flash memory, 2-way instruction cache ON, PREFETCH ON	104
Table 25.	Typical and maximum current consumption in Run mode, code with data processing running from flash memory, 1-way instruction cache ON, PREFETCH ON	105
Table 26.	Typical and maximum current consumption in Run mode, code with data processing running from SRAM with cache 1-way	105
Table 27.	Typical and maximum current consumption in Run mode, code with data processing running from SRAM with cache 2-way	106
Table 28.	Typical consumption in Run mode with CoreMark running from flash memory and SRAM	107
Table 29.	Typical consumption in Run mode with SecureMark running from flash memory and SRAM	108
Table 30.	Typical and maximum current consumption in Sleep mode	108
Table 31.	Typical and maximum current consumption in Stop mode	109
Table 32.	Typical and maximum current consumption in Standby mode	109
Table 33.	Typical and maximum current consumption in VBAT mode	110
Table 34.	Peripheral current consumption in Sleep mode	111
Table 35.	Low-power mode wake-up timings	114
Table 36.	High-speed external user clock characteristics.	114
Table 37.	Low-speed external user clock characteristics	116
Table 38.	4 to 50 MHz HSE oscillator characteristics.	116
Table 39.	Low-speed external user clock characteristics	118
Table 40.	HSI48 oscillator characteristics.	119
Table 41.	HSI oscillator characteristics.	119
Table 42.	CSI oscillator characteristics.	120

Table 43.	LSI oscillator characteristics	121
Table 44.	PLL characteristics (wide VCO frequency range)	121
Table 45.	PLL characteristics (medium VCO frequency range)	122
Table 46.	Flash memory characteristics	123
Table 47.	Flash memory programming	123
Table 48.	Flash memory endurance and data retention	124
Table 49.	EMS characteristics	125
Table 50.	EMI characteristics	126
Table 51.	ESD absolute maximum ratings	126
Table 52.	Electrical sensitivities	126
Table 53.	I/O current injection susceptibility	127
Table 54.	I/O static characteristics	127
Table 55.	Output voltage characteristics for all I/Os except PC13, PC14, and PC15.	130
Table 56.	Output voltage characteristics for FT_c I/Os	131
Table 57.	Output voltage characteristics for PC13	131
Table 58.	Output voltage characteristics for PC14 and PC15	132
Table 59.	Output timing characteristics (HSLV OFF)	133
Table 60.	Output timing characteristics (HSLV ON)	137
Table 61.	Output timing characteristics VDDIO2 1.2 V range (HSLV OFF)	138
Table 62.	Output timing characteristics VDDIO2 1.2 V (HSLV ON)	140
Table 63.	Output timing characteristics for FT_c I/Os (PB13/PB14).	141
Table 64.	NRST pin characteristics	142
Table 65.	EXTI input characteristics	142
Table 66.	PLAY timing measurement	143
Table 67.	PLAY filter characteristics	143
Table 68.	Asynchronous non-multiplexed SRAM/PSRAM/NOR read timings	146
Table 69.	Asynchronous non-multiplexed SRAM/PSRAM/NOR read-NWAIT timings	146
Table 70.	Asynchronous non-multiplexed SRAM/PSRAM/NOR write timings	147
Table 71.	Asynchronous non-multiplexed SRAM/PSRAM/NOR write-NWAIT timings	148
Table 72.	Asynchronous multiplexed PSRAM/NOR read timings	149
Table 73.	Asynchronous multiplexed PSRAM/NOR read-NWAIT timings	149
Table 74.	Asynchronous multiplexed PSRAM/NOR write timings	151
Table 75.	Asynchronous multiplexed PSRAM/NOR write-NWAIT timings	151
Table 76.	Synchronous multiplexed NOR/PSRAM read timings	153
Table 77.	Synchronous multiplexed PSRAM write timings	155
Table 78.	Synchronous non-multiplexed NOR/PSRAM read timings	156
Table 79.	Synchronous non-multiplexed PSRAM write timings	157
Table 80.	Switching characteristics for NAND flash read cycles	160
Table 81.	Switching characteristics for NAND flash write cycles	160
Table 82.	SDRAM read timings	161
Table 83.	LPSDR SDRAM read timings	162
Table 84.	SDRAM write timings	163
Table 85.	LPSDR SDRAM write timings	163
Table 86.	OCTOSPI characteristics in SDR mode	164
Table 87.	OCTOSPI characteristics in DTR mode (no DQS)	165
Table 88.	OCTOSPI characteristics in DTR mode (with DQS) / HyperBus	166
Table 89.	Delay block characteristics	168
Table 90.	12-bit ADC characteristics	168
Table 91.	Minimum sampling time versus R_{AIN}	171
Table 92.	ADC accuracy	174
Table 93.	DAC characteristics	177
Table 94.	DAC accuracy	179

Table 95.	Analog temperature sensor characteristics	180
Table 96.	Temperature sensor calibration values	181
Table 97.	Digital temperature sensor characteristics	181
Table 98.	V _{CORE} monitoring characteristics	181
Table 99.	V _{BAT} monitoring characteristics	182
Table 100.	V _{BAT} charging characteristics	182
Table 101.	Temperature monitoring characteristics	182
Table 102.	Voltage booster for analog switch characteristics	182
Table 103.	V _{REFBUF} characteristics	183
Table 104.	COMP characteristics	184
Table 105.	TIMx characteristics	185
Table 106.	LPTIMx characteristics	186
Table 107.	I2C analog filter characteristics	186
Table 108.	USART characteristics	187
Table 109.	I3C open-drain measured timings	189
Table 110.	I3C push-pull measured timings	189
Table 111.	SPI characteristics	190
Table 112.	I ² S dynamic characteristics	193
Table 113.	USB DC electrical characteristics	195
Table 114.	USB startup time	195
Table 115.	USB electrical characteristics	195
Table 116.	USB BCD DC electrical characteristics	196
Table 117.	UCPD electrical characteristics	197
Table 118.	Dynamic characteristics: SD/MMC, VDD = 2.7 to 3.6 V	197
Table 119.	Dynamic characteristics: eMMC, VDD = 1.71 to 1.9 V	198
Table 120.	Dynamic characteristics: Ethernet MAC signals for SMI	200
Table 121.	Dynamic characteristics: Ethernet MAC signals for RMII	200
Table 122.	Dynamic characteristics: Ethernet MAC signals for MII	200
Table 123.	Dynamic JTAG characteristics	202
Table 124.	Dynamic SWD characteristics	202
Table 125.	LQFP48 - Mechanical data	206
Table 126.	UFQFPN48 - Mechanical data	209
Table 127.	WLCSP63 - Mechanical data	211
Table 128.	LQFP64 - Mechanical data	213
Table 129.	LQFP100 - Mechanical data	216
Table 130.	LQFP100 - Mechanical data	219
Table 131.	UFBGA100 - Mechanical data	222
Table 132.	UFBGA100 - Example of PCB design rules (0.5 mm pitch BGA)	223
Table 133.	LQFP144 - Mechanical data	225
Table 134.	LQFP144 - Mechanical data	228
Table 135.	UFBGA144 - Mechanical data	231
Table 136.	UFBGA144 - Example of PCB design rules (0.80 mm pitch BGA)	232
Table 137.	Package thermal characteristics	233
Table 138.	Document revision history	237

List of figures

Figure 1.	STM32H543xx block diagram.	17
Figure 2.	STM32H543xx power supply overview.	27
Figure 3.	Power-up/down sequence	28
Figure 4.	LDO supply and LDO bypass	28
Figure 5.	LQFP48 pinout	60
Figure 6.	UFQFPN48 pinout	60
Figure 7.	WLCSP63 ballout	61
Figure 8.	LQFP64 pinout	61
Figure 9.	LQFP100 pinout	62
Figure 10.	LQFP100-EP pinout	63
Figure 11.	UFBGA100 ballout	63
Figure 12.	LQFP144 pinout	64
Figure 13.	LQFP144-EP pinout	65
Figure 14.	UFBGA144 ballout	66
Figure 15.	Pin loading conditions.	93
Figure 16.	Pin input voltage	93
Figure 17.	Power supply scheme.	94
Figure 18.	External capacitor C_{EXT}	100
Figure 19.	High-speed external clock source AC timing diagram	115
Figure 20.	Low-speed external clock source AC timing diagram	116
Figure 21.	Typical application with an 8 MHz crystal	117
Figure 22.	Typical application with a 32.768 kHz crystal	118
Figure 23.	VIL/VIH for all I/Os except BOOT0	129
Figure 24.	Recommended NRST pin protection	142
Figure 25.	PLAY timing diagram	143
Figure 26.	Asynchronous non-multiplexed SRAM/PSRAM/NOR read waveforms	145
Figure 27.	Asynchronous non-multiplexed SRAM/PSRAM/NOR write waveforms	147
Figure 28.	Asynchronous multiplexed PSRAM/NOR read waveforms.	148
Figure 29.	Asynchronous multiplexed PSRAM/NOR write waveforms	150
Figure 30.	Synchronous multiplexed NOR/PSRAM read timings	152
Figure 31.	Synchronous multiplexed PSRAM write timings.	154
Figure 32.	Synchronous non-multiplexed NOR/PSRAM read timings	156
Figure 33.	Synchronous non-multiplexed PSRAM write timings	157
Figure 34.	NAND controller waveforms for read access	158
Figure 35.	NAND controller waveforms for write access	159
Figure 36.	NAND controller waveforms for common memory read access.	159
Figure 37.	NAND controller waveforms for common memory write access.	160
Figure 38.	SDRAM read access waveforms (CL = 1)	161
Figure 39.	SDRAM write access waveforms	162
Figure 40.	OCTOSPI SDR read/write timing diagram	164
Figure 41.	OCTOSPI timing diagram - DTR mode.	167
Figure 42.	OCTOSPI HyperBus clock	167
Figure 43.	OCTOSPI HyperBus read.	167
Figure 44.	OCTOSPI HyperBus write	168
Figure 45.	ADC conversion timing diagram	173
Figure 46.	ADC accuracy characteristics.	175
Figure 47.	Typical connection diagram when using the ADC with FT/TT pins featuring analog switch function	175

Figure 48.	Power supply and reference decoupling (V_{REF+} not connected to V_{DDA}).	176
Figure 49.	Power supply and reference decoupling (V_{REF+} connected to V_{DDA}).	176
Figure 50.	12-bit buffered/non-buffered DAC.	180
Figure 51.	USART timing diagram in Master mode.	188
Figure 52.	USART timing diagram in Slave mode.	188
Figure 53.	SPI timing diagram - Master mode.	191
Figure 54.	SPI timing diagram - Slave mode and $CPHA = 0$.	192
Figure 55.	SPI timing diagram - Slave mode and $CPHA = 1$.	192
Figure 56.	I ² S slave timing diagram (Philips protocol) ⁽¹⁾ .	194
Figure 57.	I ² S master timing diagram (Philips protocol) ⁽¹⁾ .	194
Figure 58.	USB timings - definition of data signal rise and fall time.	195
Figure 59.	SDIO high-speed/eMMC timing.	199
Figure 60.	SD default speed timings.	199
Figure 61.	DDR mode timings.	199
Figure 62.	Ethernet RMII timing diagram.	201
Figure 63.	Ethernet MII timing diagram.	201
Figure 64.	Ethernet SMI timing diagram.	202
Figure 65.	JTAG timing diagram.	203
Figure 66.	SWD timing diagram.	203
Figure 67.	LQFP48 - Outline ⁽¹⁵⁾ .	205
Figure 68.	LQFP48 - Footprint example.	207
Figure 69.	UFQFPN48 - Outline.	208
Figure 70.	UFQFPN48 - Footprint example.	209
Figure 71.	WLCSP63 - Outline.	210
Figure 72.	LQFP64 - Outline ⁽¹⁵⁾ .	212
Figure 73.	LQFP64 - Footprint example.	214
Figure 74.	LQFP100 - Outline ⁽¹⁵⁾ .	215
Figure 75.	LQFP100 - Footprint example.	217
Figure 76.	LQFP100 - Outline.	218
Figure 77.	LQFP100 - Footprint example.	220
Figure 78.	UFBGA100 - Outline ⁽¹³⁾ .	221
Figure 79.	UFBGA100 - Footprint example.	223
Figure 80.	LQFP144 - Outline ⁽¹⁵⁾ .	224
Figure 81.	LQFP144 - Footprint example.	226
Figure 82.	LQFP144 - Outline.	227
Figure 83.	LQFP144 - Footprint example.	229
Figure 84.	UFBGA144 - Outline ⁽¹³⁾ .	230
Figure 85.	UFBGA144 - Footprint example.	232

1 Introduction

This document provides the ordering information and mechanical device characteristics of the STM32H543xx microcontrollers.

For information on the device errata with respect to the datasheet and reference manual, refer to the STM32H543xx errata sheet.

For information on the Arm[®] Cortex[®]-M33 core, refer to the Cortex[®]-M33 Technical Reference Manual, available from the www.arm.com website.



Note: Arm and Cortex are registered trademarks of Arm Limited (or its subsidiaries or affiliates) in the US and/or elsewhere.

Arm and TrustZone are registered trademarks of Arm Limited (or its subsidiaries or affiliates) in the US and/or elsewhere.

The Arm word and logo are trademarks of Arm Limited (or its subsidiaries) in the US and/or elsewhere. All rights reserved.

2 Description

The STM32H543xx devices are high-performance microcontrollers of the STM32H5 series, based on the high-performance Arm[®] Cortex[®]-M33 32-bit RISC core. They operate at a frequency of up to 250 MHz.

The Cortex[®]-M33 core features a single-precision floating-point unit (FPU), which supports all the Arm[®] single-precision data-processing instructions and all the data types. This core implements a full set of DSP (digital signal processing) instructions and a memory protection unit (MPU) that enhances the application security.

The devices embed high-speed memories (up to 1 Mbyte of dual bank flash memory and 304 Kbytes of SRAM), a flexible external memory controller (FMC) for devices with packages of 100 pins and more, one OCTOSPI memory interface (at least one Quad-SPI available on all packages), and an extensive range of enhanced I/Os and peripherals connected to three APB buses, three AHB buses, and a 32-bit multi-AHB bus matrix.

The devices offer security foundation compliant with the trusted-based security architecture (TBSA) requirements from Arm[®]. They embed the necessary security features to implement a secure boot, secure data storage and secure firmware update. Besides these capabilities, the devices incorporate a secure firmware installation that allows the customer to secure the provisioning of the code during its production. A flexible life cycle is managed thanks to multiple levels of protection and secure debug authentication. Firmware hardware isolation is supported thanks to securable peripherals, memories, and I/Os, and to privilege configuration of peripherals and memories.

The devices feature several protection mechanisms for embedded flash memory and SRAM: readout protection, write protection, secure, and hide protection areas.

Dedicated peripherals reinforce security: an HASH hardware accelerator, and a true random number generator.

The devices offer active tamper detection and protection against transient and environmental perturbation attacks, thanks to several internal monitoring, generating secret data erase in case of attack. This helps to fit the PCI requirements for point of sales applications.

The devices offer three fast 12-bit ADCs, two DAC channels, an internal voltage reference buffer, two comparators, a low-power RTC, two 32-bit general-purpose timers, two 16-bit PWM timers dedicated to motor control, four 16-bit general-purpose timers, two 16-bit basic timers, and two 16-bit low-power timers.

The devices also feature standard and advanced communication interfaces, namely: three I²Cs, two I3Cs, four SPIs, four USARTs, four UARTs and one low-power UART, one SDMMC, two FDCANs, one USB full-speed, one USB Type-C[®]/USB power delivery controller, one programmable logic array (PLAY).

The devices operate in the -40 to +85°C, -40 to +105°C, and, with exposed pad package, -40 to 125°C temperature ranges, with a 1.71 to 3.6 V power supply.

A comprehensive set of power-saving modes enables the design of low-power applications.

Independent power supplies are supported: an analog independent supply input for ADC, DACs, a 3.3 V dedicated supply input for USB, and a dedicated supply input for some GPIOs and SDMMC. A VBAT input is available to connect a backup battery, to preserve the RTC functionality, and to backup 32 32-bit registers and a 2-Kbyte SRAM.

The devices offer eight packages, from 48 to 144 pins.

Table 2. STM32H543xx features and peripheral counts

Peripherals		STM32H543CG STM32H543CE	STM32H543UG	STM32H543RG STM32H543RE	STM32H543VG STM32H543VE	STM32H543ZG STM32H543ZE
Flash memory (Mbytes)		Up to 1				
SRAM	System (Kbytes)	304 (128 + 80 + 96)				
	Backup (Kbytes)	2				
Flexible memory controller for external memories (FMC)		No		Yes ⁽¹⁾	Yes	
OCTOSPI		Yes				
Timers	Advanced control	2 (16 bits)				
	General purpose	2 (32 bits) + 4 (16 bits)				
	Basic	2 (16 bits)				
	Low power	2 (16 bits)				
	SysTick timer	2				
	Watchdog timers (independent, window)	2				
Communication interfaces	SPI / I2S	4 / 3				
	I2C	2		3		
	I3C	2				
	USART	4				
	UART	3		4		
	LPUART	1				
	FDCAN	2				
	USB FS	Yes				
	UCPD	Yes				
	SDMMC	No	Yes			
	Ethernet	No	Yes			
PLAY		Yes				
HDMI-CEC		Yes				
CORDIC coprocessor		Yes				
Real time clock (RTC)		Yes				
Tamper pins		4	5		8	
Active tampers ⁽²⁾		3	4		7	

Prerelease product(s)

Table 2. STM32H543xx features and peripheral counts (continued)

Peripherals		STM32H543CG STM32H543CE	STM32H543UG	STM32H543RG STM32H543RE	STM32H543VG STM32H543VE	STM32H543ZG STM32H543ZE
True random number generator		Yes				
PKA (EDCSA signature verification)		Yes				
HASH (SHA-1, SHA-2, SHA-3)		Yes				
GPIOs		35	47	49	80	112
Wake-up pins		4	5	7		
Number of I/Os down to 1.08 V		N/A			4 ⁽³⁾	10
ADC	12-bit ADC	3				
	Number of channels	13	19		26	30
DAC	12-bit DAC controller	1				
	Number of channels	2				
COMP		2				
Internal voltage reference buffer		No	Yes	No	Yes	
Maximum CPU frequency		250 MHz				
Operating voltage		1.71 to 3.6 V				
Operating temperature	Ambient	-40 to 85, -40 to 105, -40 to 125°C				
	Junction	-40 to 105°C (voltage range VOS0, up to 250 MHz) -40 to 140°C (voltage range VOS1, up to 200 MHz)				
Package		UFQFPN48 LQFP48	WLCSP63	LQFP64	LQFP100 LQFP100-EP UFBGA100	LQFP144 LQFP144-EP UFBGA144

1. For the LQFP100 package, only FMC Bank1 is available. Bank1 can only support a multiplexed NOR/PSRAM memory using the NE1 chip select.
2. Active tamper in output sharing mode (one output shared by all inputs).
3. Available only on UFBGA100 package.

Figure 1. STM32H543xx block diagram



Note: PC[15:13] are in the V_{BAT} domain.

Prerelease product(s)

3 Functional overview

3.1 Arm Cortex-M33 core with TrustZone and FPU

The Cortex-M33 with TrustZone and FPU is a highly energy-efficient processor designed for microcontrollers and deeply embedded applications, especially those requiring efficient security. This processor delivers a high computational performance with low-power consumption and an advanced response to interrupts. It features:

- Arm TrustZone technology, using the Armv8-M main extension supporting secure and nonsecure states
- Memory protection units (MPUs), supporting up to 16 regions for secure and nonsecure applications
- Configurable secure attribute unit (SAU) supporting up to eight memory regions as secure or nonsecure
- Floating-point arithmetic functionality with support for single precision arithmetic

The processor supports a set of DSP instructions that allows an efficient signal processing and a complex algorithm execution.

The Cortex-M33 processor supports the following bus interfaces:

- System AHB bus:
The system AHB (S-AHB) bus interface is used for any instruction fetch and data access to the memory-mapped SRAM, peripheral, external RAM and external device, or Vendor_SYS regions of the Armv8-M memory map.
- Code AHB bus:
The code AHB (C-AHB) bus interface is used for any instruction fetch and data access to the code region of the Armv8-M memory map.

Figure 1 shows the general block diagram of the STM32H543xx devices.

3.2 ART Accelerator (ICACHE and DCACHE)

3.2.1 Instruction cache (ICACHE)

The instruction cache (ICACHE) is introduced on C-AHB code bus of Cortex-M33 processor to improve performance when fetching instruction (or data) from both internal and external memories.

ICACHE offers the following features:

- Multi-bus interface:
 - Slave port receiving the memory requests from the Cortex-M33 C-AHB code execution port
 - Master1 port performing refill requests to internal memories (flash memory and SRAMs)
 - Master2 port performing refill requests to external memories (external flash memory and RAMs through Octo-SPI and FMC interfaces)
 - Second slave port dedicated to ICACHE registers access

- Close to 0 wait-states instructions/data access performance:
 - 0 wait-states on cache hit
 - Hit-under-miss capability, allowing to serve new processor requests while a line refill (due to a previous cache miss) is still ongoing
 - Critical-word-first refill policy, minimizing processor stalls on cache miss
 - Hit ratio improved by two-way set-associative architecture and pLRU-t replacement policy (pseudo-least-recently-used, based on binary tree), algorithm with best complexity/performance balance
 - Dual master ports to decouple internal and external memory traffic, respectively, on fast and slow buses, minimizing impact on interrupt latency
 - Optimal cache line refill thanks to AHB burst transactions (of the cache line size)
 - Performance monitoring by means of a hit counter and a miss counter
- Extension of cacheable region beyond the code memory space, by means of address remapping logic that allows four cacheable external regions to be defined
- Power consumption reduced intrinsically (more accesses to cache memory rather than to bigger main memories); even improved by configuring ICACHE as direct mapped (rather than the default two-way set-associative mode)
- TrustZone security support
- Maintenance operation for software management of cache coherency
- Error management: detection of unexpected cacheable write access, with optional interrupt raising

3.2.2 Data cache (DCACHE)

The data cache (DCACHE) is introduced on S-AHB system bus of Cortex-M33 processor to improve the performance of data traffic to/from external memories. DCACHE offers the following features:

- Multi-bus interface:
 - Slave port receiving the memory requests from the Cortex-M33 S-AHB system port
 - Master port performing refill requests to external memories (external flash memory and RAMs through Octo-SPI and FMC interfaces)
 - A second slave port dedicated to DCACHE registers access
- Close to 0 wait-states external data access performance:
 - 0 wait-states on cache hit
 - Hit-under-miss capability, allowing to serve new processor requests to cached data, while a line refill (due to a previous cache miss) is still ongoing
 - Critical-word-first refill policy for read transactions, minimizing processor stalls on cache miss
 - Hit ratio improved by two-way set-associative architecture and pLRU-t replacement policy (pseudo-least-recently-used, based on binary tree), algorithm with best complexity/performance balance
 - Optimal cache line refill thanks to AHB burst transactions (of the cache line size)
 - Performance monitoring by means of two hit counters (for read and write) and two miss counters (for read and write)

- Supported cache accesses:
 - Supports both write-back and write-through policies (selectable with AHB bufferable attribute)
 - Read and write-back always allocated
 - Write-through always non-allocated (write-around)
 - Supports byte, half-word, and word writes
- TrustZone security support
- Maintenance operations for software management of cache coherency:
 - Full cache invalidation (non interruptible)
 - Address range clean and/or invalidate operations (background task, interruptible)
- Error management: detection of error for master port request initiated by DCACHE (line eviction or clean operation), with optional interrupt raising

3.3 Memory protection unit

The memory protection unit (MPU) is used to manage the CPU accesses to the memory and to prevent one task to accidentally corrupt the memory or the resources used by other active tasks. This memory area is organized into up to 20 protected areas (12 secure and 8 nonsecure). The MPU regions and registers are banked across secure and nonsecure states.

The MPU is especially helpful for applications where critical or certified code must be protected against the misbehavior of other tasks. It is usually managed by an RTOS (real-time operating system).

If a program accesses a memory location prohibited by the MPU, the RTOS can detect it and take action. In an RTOS environment, the kernel can dynamically update the MPU area settings based on the process to be executed.

3.4 Embedded flash memory

The devices feature up to 1 Mbyte of embedded flash memory for storing programs and data. The flash memory supports a high-cycle data area of up to 100 K cycles.

The flash memory interface features dual-bank operating modes, and read-while-write (RWW). A read operation can be performed on one bank, while an erase or program operation is performed on the other bank. Each bank contains 64 8-Kbyte pages.

The flash memory embeds a 2-Kbyte OTP (one-time programmable) for user data, and up to 96 Kbytes supporting high cycling capability (100 K cycles), to use for data (EEPROM emulation).

Option bytes are available to set the flash memory protection mechanisms:

- Different product states for protecting memory content from debug access
- Write protection (WRP) to protect areas against erasing and programming. Two areas per bank can be selected with 8-Kbyte granularity.
- Sector group write-protection (WRPSG), protecting up to 32 groups of four sectors (32 Kbytes) per bank
- Two secure-only areas (one per user flash memory bank). When enabled, this area is accessible only if the device operates in Secure-access mode

- One HDP area per bank providing temporal isolation for startup code

The whole non-volatile memory embeds the error correction code (ECC) feature supporting:

- Single-error detection and correction
- Double-error detection
- ECC fail address report

3.4.1 FLASH security and protections

Sensitive information is stored in the flash memory and it is important to protect the memory against unwanted operations such as reading confidential areas, illegal programming of immutable sectors, or malicious flash memory erasing.

For that purpose the following protection mechanisms are implemented:

- TrustZone backed watermark and block security protection
- Temporal isolation protection (HDP)
- Configuration protection
- User flash memory write protection
- Device non-volatile security life cycle and application boot state management
- OTP locking

Refer to the product reference manual for a detailed description of the security mechanisms.

3.4.2 FLASH privilege protection

Each flash memory sector can be programmed on the fly as privileged or unprivileged.

3.5 Embedded SRAMs

Four SRAMs are embedded in the STM32H543xx devices, each with specific features. SRAM1, SRAM2, and SRAM3 are the main ones.

These SRAMs are made of several blocks that can be powered down in Stop mode to reduce consumption:

- SRAM1: 128 Kbytes
- SRAM2: 80 Kbytes with ECC
- SRAM3: 96 Kbytes (the first 64 Kbytes with ECC, the next 16 Kbytes without, the last 16 Kbytes used to store the ECC)
- BKPSRAM (backup SRAM): 2 Kbytes with ECC, can be retained in all low-power modes and when V_{DD} is off in VBAT mode

Note: The ECC is supported by SRAM2, and BKPSRAM when enabled with the SRAM2_ECC, SRAM3_ECC, and BKPRAM_ECC user option bits.

3.5.1 SRAMs TrustZone security

When the TrustZone security is enabled, all SRAMs are secure after reset. The SRAM1, SRAM2, SRAM3, can be programmed as secure or nonsecure by blocks, using the MPCBB (block-based memory protection controller).

The granularity of SRAM secure block based is a page of 512 bytes. Backup SRAM regions can be programmed as secure or nonsecure with watermark, using the TZSC (TrustZone security controller) in the GTZC (global TrustZone controller).

3.5.2 SRAMs privilege protection

SRAM1, SRAM2, and SRAM3 can be programmed as privileged or non-privileged by blocks, using the MPCBB. The granularity of SRAM privilege block based is a page of 512 bytes. Backup SRAM regions can be programmed as privileged or non-privileged with watermark, using the TZSC (TrustZone security controller) in the GTZC (global TrustZone controller).

3.6 Security overview

The STM32H543xx security enables the possibility to reopen the debug mode even if the product is in secure state.

The reopening of the debug mode is controlled with a debug authentication procedure which permits the authentication of the host.

Sensible assets (such as keys or secret codes) must be protected when opening the debug mode. The protection is made via code protection and hardware keys storage solutions where all *root of trust* can be protected thanks to hardware mechanisms.

In cases where sensitive information cannot be protected, a partial or a full regression can be launched to start a debug. Regressions are enabled by a debug authentication method.

Developers can introduce their own root of trust solution (OEM-iROT), including their installation in a non-trusted environment, thanks to a secure firmware install (SFI) solution.

The boot stages are isolated via a hardware mechanism called HDPL (temporal isolation level). The HDPL guarantees isolation of the different boot stages: ST assets, iROT (immutable root of trust), uROT (updatable root of trust), secure operating system and nonsecure applications.

The devices are powered by an Arm Cortex-M33 core, associated with all the TrustZone isolation infrastructure. This design permits to benefit from a run time isolation to run secure applications.

3.7 Boot modes

At startup, a BOOT0 pin and NSBOOTADD[31:8]/SECBOOTADD[31:8] option bytes are used to select the boot memory address that includes:

- Boot from any address in user flash memory
- Boot from system memory
 - Bootloader
 - Root security service (RSS)
 - Debug authentication library (RSS-DA)

Embedded bootloader

The embedded bootloader is located in the system memory, programmed by ST during production. It is used to reprogram the flash memory by using USART, I2C, I3C, SPI, FDCAN, or USB in device mode through the DFU (device firmware upgrade).

Refer to AN2606 “*Introduction to system memory boot mode on STM32 MCUs*”.

Embedded root security services (RSS)

The embedded RSS are located in the secure information block, programmed by ST during production.

Refer to AN4992 “*Introduction to secure firmware install (SFI) for STM32 MCUs*”.

Embedded debug authentication (ST-DA)

The embedded ST-DA in the system memory is programmed by ST during production. ST-DA is the library that manages the debug authentication protocol, making it possible to securely reopen the debug or to launch regressions on secured products in the field.

3.8 Global TrustZone controller (GTZC)

GTZC is used to configure TrustZone and privileged attributes within the full system.

The GTZC includes three different sub-blocks:

- TZSC: TrustZone security controller

This sub-block defines the secure/privilege state of slave/master peripherals. It also controls the nonsecure area size for the watermark memory peripheral controller (MPCWM). The TZSC block informs some peripherals (such as RCC or GPIOs) about the secure status of each securable peripheral, by sharing with RCC and I/O logic.
- TZIC: TrustZone illegal access controller

This sub-block gathers all security illegal access events in the system and generates a secure interrupt towards NVIC.
- MPCBB: MPCBB: block-based memory protection controller

This sub-block controls secure states of all memory blocks (512-byte pages) of the associated SRAM. This peripheral aims at configuring the internal RAM in a TrustZone system product having segmented SRAM with programmable-security and privileged attributes.

The GTZC main features are:

- Three independent 32-bit AHB interfaces for TZSC, TZIC and MPCBB

- MPCBB and TZIC accessible only with secure transactions
 - Enable illegal access events that may trigger a secure interrupt
- Secure and nonsecure access supported for privileged/non-privileged part of TZSC
- Set of registers to define product security settings:
 - Secure/privilege regions for external memories
 - Secure/privilege access mode for securable peripherals
 - Secure/privilege access mode for securable legacy masters

3.9 TrustZone security architecture

The security architecture is based on Arm TrustZone with the Armv8-M main extension.

The TrustZone security is activated by the TZEN option bit in the FLASH_OTPR register.

When the TrustZone is enabled, the SAU (security attribution unit) and IDAU (implementation defined attribution unit) define the access permissions based on secure and nonsecure state.

- SAU: up to eight SAU configurable regions are available for security attribution.
- IDAU: It provides a first memory partition as nonsecure or nonsecure callable attributes. It is then combined with the results from the SAU security attribution and the higher security state is selected.

Based on IDAU security attribution, the flash memory, system SRAMs and peripherals memory space is aliased twice for secure and nonsecure states. However, the external memories space is not aliased.

3.9.1 TrustZone peripheral classification

When the TrustZone security is active, a peripheral can be either securable or TrustZone-aware type as follows:

- securable: peripheral protected by an AHB/APB firewall gate controlled from TZSC to define security properties
- TrustZone-aware: peripheral connected directly to AHB or APB bus and implementing a specific TrustZone behavior such as a subset of registers being secure

3.9.2 Default TrustZone security state

The default system security state is detailed below:

- CPU:
 - Cortex-M33 is in secure state after reset. The boot address must be in secure address.
- Memory map:
 - SAU is fully secure after reset. Consequently, all memory map is fully secure. Up to eight SAU configurable regions are available for security attribution.
- Flash memory:
 - Flash memory security area is defined by watermark user options.
 - Flash memory block based area is nonsecure after reset.
- SRAMs:

- All SRAMs are secure after reset. MPCBB (memory protection block based controller) is secure.
- External memories:
 - FMC, OCTOSPI banks are secure after reset. MPCWMx (memory protection watermark based controller) is secure.
- Peripherals
 - Securable peripherals are nonsecure after reset.
 - TrustZone-aware peripherals are nonsecure after reset. Their secure configuration registers are secure.
- All GPIOs are secure after reset.
- Interrupts:
 - NVIC: All interrupts are secure after reset. NVIC is banked for secure and nonsecure state.
- TZIC: All illegal access interrupts are disabled after reset.

3.10 Power supply management

The power controller (PWR) main features are:

- Power supplies and supply domains
 - Core domain (V_{CORE})
 - V_{DD} domain
 - Backup domain (V_{BAT})
 - Analog domain (V_{DDA})
 - V_{DDIO2} domain
 - V_{DDUSB}
- System supply voltage regulation
 - Voltage regulator (LDO)
- Power supply supervision
 - POR/PDR monitor
 - BOR monitor
 - PVD monitor
- Power management
 - Operating modes
 - Voltage scaling control
 - Low-power modes
- VBAT battery charging
- TrustZone security and privileged protection

3.10.1 Power supply schemes

The devices require a 1.71 to 3.6 V V_{DD} operating voltage supply. Several independent supplies can be provided for specific peripherals:

- $V_{DD} = 1.71\text{ V to }3.6\text{ V}$
 V_{DD} is the external power supply for the I/Os, the internal regulator and the system

analog such as reset, power management and internal clocks. It is provided externally through the VDD pins.

- $V_{DDA} = 1.62\text{ V}$ (ADCs, COMP), 1.8 V (DACs), or 2.1 V (VREFBUF) to 3.6 V
 V_{DDA} is the external analog power supply for ADCs, DACs and voltage reference buffer. This voltage level is independent from V_{DD} , and must preferably be connected to V_{DD} when these peripherals are not used.
- $V_{DDUSB} = 3.0\text{ V}$ to 3.6 V
 V_{DDUSB} is the external independent power supply for USB transceivers. It is independent from V_{DD} , and must preferably be connected to VDD when the USB is not used.
- $V_{DDIO2} = 1.08\text{ V}$ to 3.6 V
 V_{DDIO2} is the external power supply for ten I/Os (PD6, PD7, PG9:14, PB8, PB9). This voltage level is independent from V_{DD} , voltage and must preferably be connected to VDD when those pins are not used.
- $V_{BAT} = 1.62\text{ V}$ to 3.6 V
 V_{BAT} is the power supply for RTC, external clock 32 kHz oscillator and backup registers (through power switch) when V_{DD} is not present.
- VREF-, VREF+
 V_{REF+} is the input reference voltage for ADCs and DACs. It is also the output of the internal voltage reference buffer when enabled.
 V_{REF+} can be grounded when ADC and DAC are not active.
VREF- and VREF+ pins are not available on all packages. When not available, they are bonded to VSSA and VDDA, respectively.
When the VREF+ is double-bonded with VDDA in a package, the internal voltage reference buffer is not available and must be kept disabled.
 V_{REF-} must always be equal to V_{SSA} .

The devices embed an LDO regulator to provide the V_{CORE} supply for digital peripherals, SRAM1, SRAM2, SRAM3, and embedded flash memory. The LDO generates this voltage on VCAP pin connected to an external capacitor of $2 \times 2.2\ \mu\text{F}$ (typical).

This regulator can provide four different voltages (voltage scaling), and can operate in Stop modes.

Figure 2. STM32H543xx power supply overview

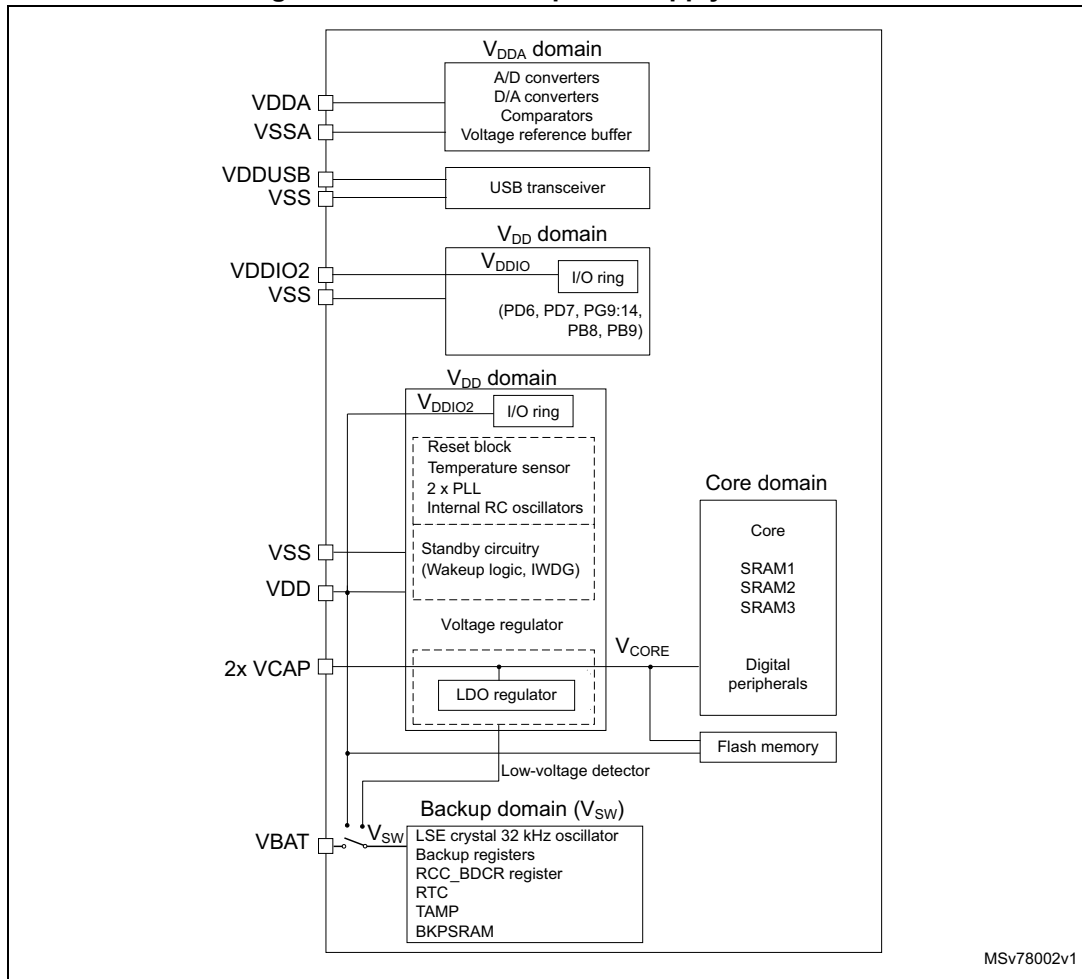

Prerelease product(s)

During power-up and power-down phases, the following power sequence requirements must be respected:

- When V_{DD} is below 1 V, other power supplies (V_DD_A, V_DD_{IO2}, V_DD_{USB}) must remain below V_{DD} + 300 mV.
- When V_{DD} is above 1 V, all power supplies are independent.
- During the power-down phase, V_{DD} can temporarily become lower than other supplies only if the energy provided to the MCU remains below 1 mJ. This allows external decoupling capacitors to be discharged with different time constants during the power-down transient phase.

Figure 3. Power-up/down sequence

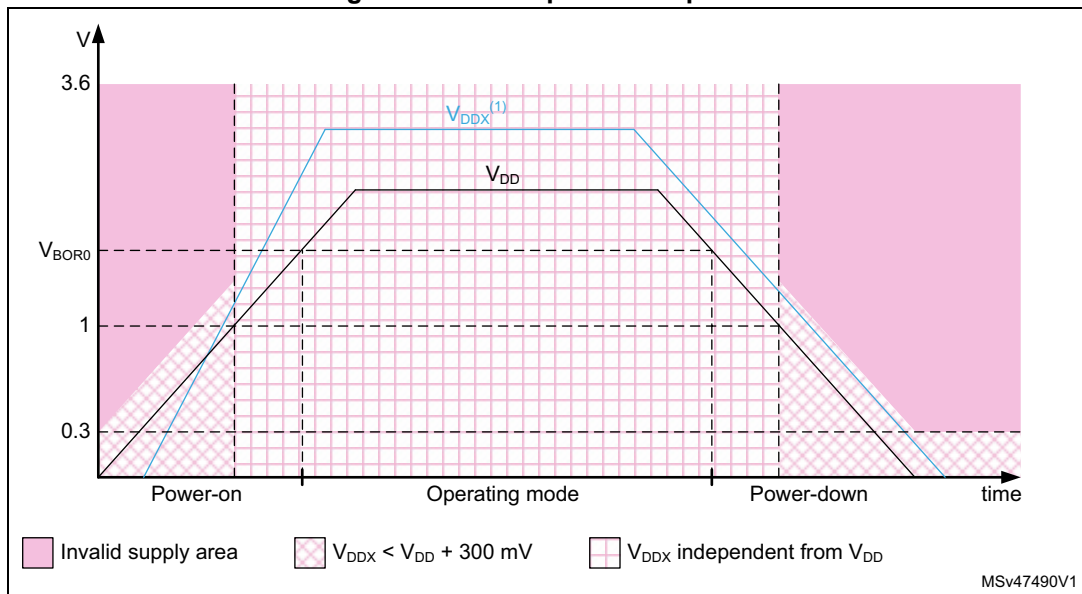

1. V_{DDX} refers to any power supply among V_{DDA}, V_{DDUSB}, and V_{DDIO2}.

3.10.2 Startup with V_{CORE} supplied by external source (Bypass)

The low-dropout (LDO) regulator can also be bypassed to allow an external power supply on V_{CORE}. When the device operates in bypass mode, the supply must first settle at its default level, which is 1.1 V or higher, before it reaches the power-on reset (POR) threshold. Since the LDO is enabled by default after power-up, the external voltage must remain above 1.1 V until software disables the LDO.

Figure 4. LDO supply and LDO bypass

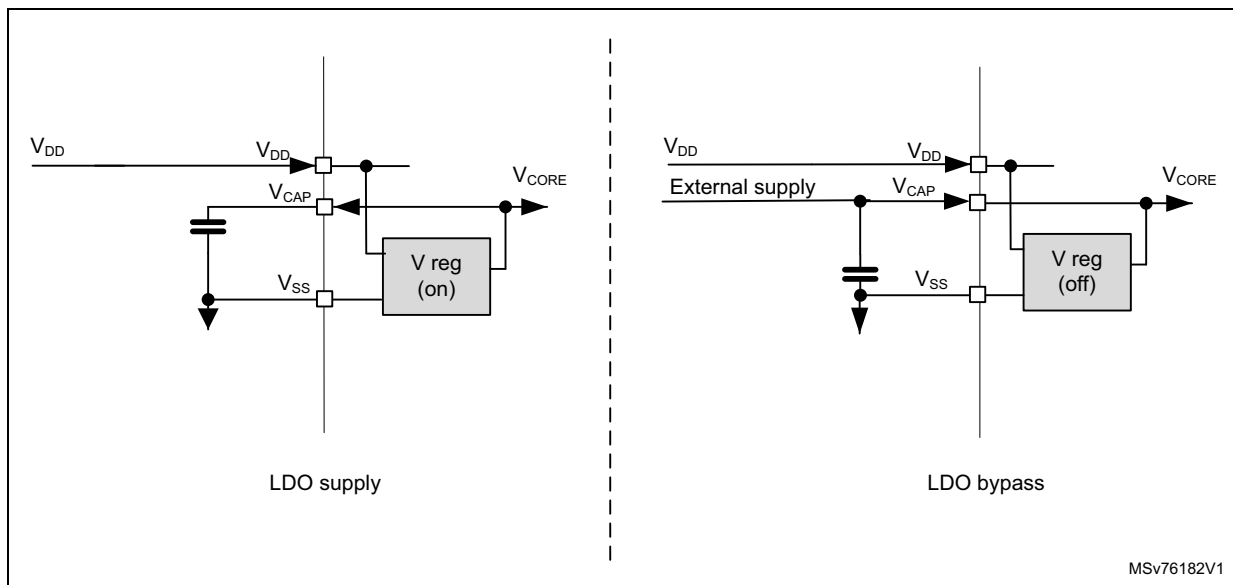

Prerelease product(s)

3.10.3 Power supply supervisor

The devices have an integrated ultra-low-power brownout reset (BOR) active in all modes; The BOR ensures proper operation of the devices after power on and during power down. The devices remain in reset mode when the monitored supply voltage V_{DD} is below a specified threshold, without the need for an external reset circuit.

The lowest BOR level is 1.71 V at power on, and other higher thresholds can be selected through option bytes. The devices feature an embedded programmable voltage detector (PVD) that monitors the V_{DD} power supply and compares it to the V_{PVD} threshold.

An interrupt can be generated when V_{DD} drops below the V_{PVD} threshold and/or when V_{DD} is higher than the V_{PVD} threshold. The interrupt service routine can then generate a warning message and/or put the MCU into a safe state. The PVD is enabled by software.

In addition, the devices embed a peripheral voltage monitor that compares the independent supply voltages V_{DDA} , V_{DDUSB} and V_{DDIO2} to ensure that the peripheral is in its functional supply range.

The devices support dynamic voltage scaling to optimize power consumption in Run mode. The voltage from the main regulator that supplies the logic (V_{CORE}) can be adjusted according to the system maximum operating frequency.

The main regulator operates in the following ranges:

- VOS0 ($V_{CORE} = 1.35$ V) with CPU and peripherals running at up to 250 MHz
- VOS1 ($V_{CORE} = 1.2$ V) with CPU and peripherals running at up to 200 MHz
- VOS2 ($V_{CORE} = 1.1$ V) with CPU and peripherals running at up to 150 MHz
- VOS3 ($V_{CORE} = 1.0$ V) with CPU and peripherals running at up to 100 MHz

Low-power modes

By default, the microcontroller is in Run mode after a system or a power reset. It is up to the user to select one of the low-power modes described below:

- **Sleep mode**
Only the CPU is stopped. All peripherals continue to operate and can wake up the CPU when an interrupt/event occurs.
- **Stop mode**
This mode achieves the lowest power consumption while retaining the content of SRAM and registers. All clocks in the V_{CORE} domain are stopped, the PLL, the CSI, the HSI, the HSI48, and the HSE crystal oscillators are disabled. The LSE or LSI is still running.
The RTC can remain active (Stop mode with RTC, Stop mode without RTC).
The system clock when exiting from Stop mode can be either HSI up to 64 MHz, or CSI (4 MHz), depending on software configuration.

- **Standby mode**

This mode is used to achieve the lowest power consumption with BOR. The PLL, the HSI, the CSI, the HSI48, and the HSE crystal oscillators are also switched off.

The RTC can remain active (Standby mode with RTC, Standby mode without RTC).

The BOR always remains active.

The I/Os state during Standby mode can be retained.

After entering Standby mode, SRAMs and register contents are lost, except for registers and backup SRAM in the Backup domain and Standby circuitry.

The device exits Standby mode when an external reset (NRST pin), an IWDG reset, a WKUP pin event (configurable rising or falling edge), an RTC event (alarm, periodic wake-up, timestamp), or a tamper detection occurs. The tamper detection can be due to external pins or to an internal failure detection.

The system clock after wake-up is HSI at 32 MHz.

3.10.4 Reset mode

To improve the consumption under reset, the I/Os state under and after reset is “analog state” (the I/O Schmitt trigger is disabled).

3.10.5 VBAT operation

The VBAT pin allows the device VBAT domain to be powered from an external battery or by an external super-capacitor.

The VBAT pin supplies the RTC with LSE, anti-tamper detection (TAMP), backup registers, and 2-Kbyte backup SRAM. Eight anti-tamper detection pins are available in VBAT mode.

The VBAT operation is automatically activated when V_{DD} is not present. An internal VBAT battery charging circuit is embedded and can be activated when V_{DD} is present.

Note: When the microcontroller is supplied from V_{BAT} , neither external interrupts nor RTC alarm/events exit it from the VBAT operation.

3.10.6 PWR TrustZone security

When the TrustZone security is activated by the TZEN option bit, the PWR is switched in TrustZone security mode.

The PWR TrustZone security secures the following configuration:

- Low-power mode
- Wake-up (WKUP) pins
- Voltage detection and monitoring
- VBAT mode

Some of the PWR configuration bits security are defined by the security of other peripherals:

- The voltage scaling (VOS) configuration is secure when the system clock selection is secure in RCC.
- The I/O pull-up/pull-down in Standby mode configuration is secure when the corresponding GPIO is secure.
- The backup domain write protection is secure when the RTC is secure.

3.11 Peripheral interconnect matrix

Several peripherals have direct connections between them, for autonomous communication, and to support the saving of CPU resources (thus power supply consumption). In addition, these hardware connections allow fast and predictable latency.

Depending on the peripherals, these interconnections can operate in Run and Sleep modes.

3.12 Reset and clock controller (RCC)

The clock controller distributes the clocks coming from the different oscillators to the core and to the peripherals. It also manages the clock gating for low-power modes and ensures the clock robustness. It features:

- **Clock prescaler:** to get the best trade-off between speed and current consumption, the clock frequency to the CPU and peripherals can be adjusted by a programmable prescaler.
- **Clock security system:** clock sources can be changed safely on the fly in Run mode through a configuration register.
- **Clock management:** to reduce the power consumption, the clock controller can stop the clock to the core, individual peripherals, or memory.
- **System clock source:** four different clock sources can be used to drive the master clock SYSCLK:
 - 4 to 50 MHz high-speed external crystal or ceramic resonator (HSE), can supply a PLL. The HSE can also be configured in bypass mode for an external clock.
 - 64 MHz high-speed internal RC oscillator (HSI), trimmable by software, can supply a PLL.
 - 4 MHz low-power internal oscillator (CSI), trimmable by software, can supply a PLL.
 - System PLL, which can be fed by HSE, HSI, or CSI, with a maximum frequency at 250 MHz.
- **RC48 with clock recovery system (HSI48):** internal 48 MHz clock source (HSI48), can be used to drive the USB.
- **UCPD kernel clock,** derived from HSI clock. The HSI RC oscillator must be enabled prior to the UCPD kernel clock use.
- **Auxiliary clock source:** two ultra-low power clock sources that can be used to drive the real-time clock:
 - 32.768 kHz low-speed external crystal (LSE), supporting four drive capability modes. The LSE can also be configured in bypass mode for an external clock.
 - 32 kHz low-speed internal RC (LSI), also used to drive the independent watchdog.
- **Peripheral clock sources:** several peripherals have their own independent clock, whatever the system clock. Two PLLs, each having two independent outputs allowing the highest flexibility, can generate independent clocks for the ADC, USB, SDMMC, RNG, FDCAN1, OCTOSPI.
- **Startup clock:** after reset, the microcontroller restarts by default with an internal 32 MHz clock (HSI/2). The prescaler ratio and clock source can be changed by the application program as soon as the code execution starts.

- **Clock security system (CSS):** this feature can be enabled by software. If a HSE clock failure occurs, the master clock automatically switches to HSI and a software interrupt is generated if enabled. LSE failure can also be detected and generates an interrupt.
- Clock-out capability:
 - **MCO (microcontroller clock output):** outputs one of the internal clocks for external use by the application.
 - **LSCO (low-speed clock output):** outputs LSI or LSE in all low-power modes (except VBAT mode).

Several prescalers allow AHB and APB frequencies configuration. The maximum frequency of the AHB and the APB clock domains is 250 MHz.

3.12.1 RCC TrustZone security

When the TrustZone security is activated by the TZEN option bit, the RCC is switched in TrustZone security mode.

The RCC TrustZone security secures some RCC system configuration and peripheral configuration clock from being read or modified by nonsecure accesses: when a peripheral is secure, the related peripheral clock, reset, clock source selection and clock enable during low-power modes control bits are secure.

A peripheral is in secure state:

- when its corresponding SEC security bit is set in the TZSC (TrustZone security controller), for securable peripherals.
- when a security feature of this peripheral is enabled through its dedicated bits, for TrustZone-aware peripherals.

3.13 Clock recovery system (CRS)

The devices embed a special block that allows automatic trimming of the internal 48 MHz oscillator to guarantee its optimal accuracy over the whole device operational range. The trimming is based on the external synchronization signal, derived from USB SOF signalization, from LSE oscillator, from an external signal on CRS_SYNC pin, or generated by user software. For faster lock-in during startup, automatic and manual trimming actions can be combined.

3.14 General-purpose inputs/outputs (GPIOs)

Each of the GPIO pins can be configured by software as output (push-pull or open-drain), as input (with or without pull-up or pull-down) or as peripheral alternate function. Most of the GPIO pins are shared with digital or analog alternate functions.

After reset, all GPIOs are in analog mode to reduce power consumption.

If needed, the I/Os alternate function configuration can be locked following a specific sequence, to avoid spurious writing to the I/Os registers.

Ten I/Os (PD6, PD7, PG9:14, PB8, PB9) can be independently supplied by a dedicated V_{DDIO} supply.

3.14.1 GPIOs TrustZone security

Each I/O pin of GPIO port can be individually configured as secure. When the selected I/O pin is configured as secure, its corresponding configuration bits for alternate function, mode selection, I/O data are secure against a nonsecure access. The associated registers bit access is restricted to a secure software only. After reset, all GPIO ports are secure.

3.15 Multi-AHB bus matrix

A 32-bit multi-AHB bus matrix interconnects all the masters (CPU, GPDMA1, GPDMA2, SDMMC1, Ethernet) and the slaves (flash memory, FMC, OCTOSPI, SRAMs, AHB and APB) peripherals. It ensures seamless and efficient operation, even when several high-speed peripherals work simultaneously.

3.16 General purpose direct memory access controller (GPDMA)

The GPDMA controller is a bus master and system peripheral. It used to perform programmable data transfers between memory-mapped peripherals and/or memories via linked-lists, upon the control of an off-loaded CPU. The GPDMA main features are:

- Dual bidirectional AHB master
- Memory-mapped data transfers from a source to a destination:
 - Peripheral-to-memory
 - Memory-to-peripheral
 - Memory-to-memory
 - Peripheral-to-peripheral
- Autonomous data transfers during Sleep mode
- Transfers arbitration based on a four-grade programmed priority at a channel level:
 - One high-priority traffic class, for time-sensitive channels (queue 3)
 - Three low-priority traffic classes, with a weighted round-robin allocation for non time-sensitive channels (queues 0, 1, 2)
- Per channel event generation, on any of the following events: transfer complete or half transfer complete or data transfer error or user setting error, and/or update linked-list item error or completed suspension
- Per channel interrupt generation, with separately programmed interrupt enable per event
- Eight concurrent DMA channels:
 - Per channel FIFO for queuing source and destination transfers
 - Intra-channel DMA transfers chaining via programmable linked-list into memory, supporting two execution modes: run-to-completion and link step mode
 - Intra-channel and inter-channel DMA transfers chaining via programmable DMA input triggers connection to DMA task completion events
- Per linked-list item within a channel:
 - Separately programmed source and destination transfers

- Programmable data handling between source and destination: byte-based reordering, packing or unpacking, padding or truncation, sign extension and left/right realignment
- Programmable number of data bytes to be transferred from the source, defining the block level
- channels with linear source and destination addressing: either fixed or contiguously incremented addressing, programmed at a block level, between successive single transfers
- Four channels with 2D source and destination addressing: programmable signed address offsets between successive burst transfers (non-contiguous addressing within a block, combined with programmable signed address offsets between successive blocks, at a second 2D/repeated block level)
- Support for scatter-gather (multi-buffer transfers), data interleaving and de-interleaving via 2D addressing
- Programmable DMA request and trigger selection
- Programmable DMA half-transfer and transfer complete events generation
- Pointer to the next linked-list item and its data structure in memory, with automatic update of the DMA linked-list control registers
- Debug:
 - Channel suspend and resume support
 - Channel status reporting including FIFO level and event flags
- TrustZone support:
 - Support for secure and nonsecure DMA transfers, independently at a first channel level, and independently at a source/destination and link sub-levels
 - Secure and nonsecure interrupts reporting, resulting from any of the respectively secure and nonsecure channels
 - TrustZone-aware AHB slave port, protecting any DMA secure resource (register, register field) from a nonsecure access
- Privileged/unprivileged support:
 - Support for privileged and unprivileged DMA transfers, independently at a channel level
 - Privileged-aware AHB slave port

3.17 Programmable logic array (PLAY)

The programmable logic array enables the user to create custom logic and state machines without the need for external programmable logic devices, such as FPGAs.

It enables the following features:

- Glitch-free programmable logic elements each comprising a 4-input look-up table and a register
- Configurable input and output interconnects
- Optional synchronization of inputs, with programmable glitch filters and edge detection/pulse extension feature.
- Software programmable inputs
- Flags with interrupt capability for communication with software
- Simple register-based configuration interface, protected by software lock
- Arm® TrustZone®-aware
- Privilege-aware

3.18 Interrupts and events

3.18.1 Nested vectored interrupt controller (NVIC)

The devices embed a nested vectored interrupt controller able to manage 16 priority levels and to handle up to 150 maskable interrupt channels plus the 16 interrupt lines of the Cortex-M33.

The NVIC benefits are the following:

- closely coupled NVIC giving low-latency interrupt processing
- interrupt entry vector table address passed directly to the core
- early processing of interrupts
- processing of late arriving higher priority interrupts
- support for tail chaining
- processor state automatically saved
- interrupt entry restored on interrupt exit with no instruction overhead
- TrustZone support: NVIC registers banked across secure and nonsecure states

The NVIC hardware block provides flexible interrupt management features with minimal interrupt latency.

3.18.2 Extended interrupt/event controller (EXTI)

The extended interrupts and event controller (EXTI) manages the individual CPU and system wake-up through configurable event inputs. It provides wake-up requests to the power control, and generates an interrupt request to the CPU NVIC and events to the CPU event input. For the CPU an additional event generation block (EVG) is needed to generate the CPU event signal.

The EXTI wake-up requests allow the system to be woken up from Stop modes.

The interrupt request and event request generation can also be used in Run modes. The EXTI also includes the EXTI multiplexer IO port selection.

The EXTI main features are the following:

- All event inputs allowed to wake up the system
- Configurable events (signals from I/Os or peripherals able to generate a pulse)
 - Selectable active trigger edge
 - Interrupt pending status register bit independent for the rising and falling edge
 - Individual interrupt and event generation mask, used for conditioning the CPU wake-up, interrupt and event generation
 - Software trigger possibility
- TrustZone secure events
 - The access to control and configuration bits of secure input events can be made secure
- EXTI IO port selection

3.19 Cyclic redundancy check calculation unit (CRC)

The CRC is used to get a CRC code using a configurable generator with polynomial value and size.

Among other applications, the CRC-based techniques are used to verify data transmission or storage integrity. In the scope of the EN/IEC 60335-1 standard, they offer a mean to verify the flash memory integrity.

The CRC calculation unit helps to compute a signature of the software during runtime, which can be ulteriorly compared with a reference signature generated at link-time and that can be stored at a given memory location.

3.20 CORDIC coprocessor (CORDIC)

The CORDIC coprocessor provides hardware acceleration of certain mathematical functions, notably trigonometric, commonly used in motor control, metering, signal processing and many other applications. It speeds up the calculation of these functions compared to a software implementation, allowing a lower operating frequency, or freeing up processor cycles in order to perform other tasks.

The CORDIC main features are:

- 24-bit CORDIC rotation engine
- Circular and hyperbolic modes
- Rotation and vectoring modes
- Functions: sine, cosine, sinh, cosh, atan, atan2, atanh, modulus, square root, natural logarithm
- Programmable precision
- Low-latency AHB slave interface
- Results can be read as soon as ready without polling or interrupt
- DMA read and write channels
- Multiple register read/write by DMA

3.21 Flexible memory controller (FMC)

The FMC includes three memory controllers:

- NOR/PSRAM memory controller
- NAND memory controller

The main features of the FMC controller are the following:

- Interface with static-memory mapped devices including:
 - Static random access memory (SRAM)
 - NOR flash memory/OneNAND flash memory
 - PSRAM (four memory banks)
 - NAND flash memory with ECC hardware to check up to 8 Kbytes of data
 - Ferroelectric RAM (FRAM, FeRAM)
- 8-, 16- bit data bus width
- Independent chip select control for each memory bank
- Independent configuration for each memory bank
- Write FIFO

3.21.1 LCD parallel interface

The FMC can be configured to interface seamlessly with most graphic LCD controllers. It supports the Intel® 8080 and Motorola® 6800 modes, and is flexible enough to adapt to specific LCD interfaces.

This LCD parallel interface capability makes it easy to build cost effective graphic applications using LCD modules with embedded controllers or high-performance solutions using external controllers with dedicated acceleration.

3.21.2 FMC TrustZone security

When the TrustZone security is enabled, the whole FMC banks are secure after reset. Nonsecure area can be configured using the TZSC MPCWMx controller.

- The FMC NOR/PSRAM bank:
 - Up to two nonsecure area can be configured through the TZSC MPCWM2 controller with a 64-Kbyte granularity
- The FMC NAND bank:
 - Can be either configured as fully secure or fully nonsecure using the TZSC MPCWM3 controller

The FMC registers can be configured as secure through the TZSC controller.

3.22 Octo-SPI interface (OCTOSPI)

The OCTOSPI supports external memories such as serial PSRAMs, serial NAND/NOR flash memories, HyperRAMs™ and HyperFlash™ memories, with the following functional modes:

- Indirect mode: all the operations are performed using the OCTOSPI registers.
- Status-polling mode: the external memory status register is periodically read and an interrupt can be generated in case of flag setting.
- Memory-mapped mode: the external memory is memory mapped and is seen by the system as if it were an internal memory supporting read and write operation.

The OCTOSPI supports the following protocols with associated frame formats:

- Standard frame format with the command, address, alternate byte, dummy cycles and data phase
- HyperBus™ frame format

The OCTOSPI offers the following features:

- Three functional modes: Indirect, Status-polling, and Memory-mapped
- Read and write support in Memory-mapped mode
- Supports for single, dual, quad and octal communication
- Dual-quad mode, where eight bits can be sent/received simultaneously by accessing two quad memories in parallel.
- SDR (single-data rate) and DTR (double-transfer rate) support
- Data strobe support
- Fully programmable opcode
- Fully programmable frame format
- HyperBus support
- Integrated FIFO for reception and transmission
- 8-, 16-, and 32-bit data accesses allowed
- DMA channel for Indirect mode operations
- Interrupt generation on FIFO threshold, timeout, operation complete, and access error
- Dual chip select
- Extended external memory support
- Possibility to disable the automatic prefetch

3.22.1 OCTOSPI TrustZone security

When the TrustZone security is enabled, the whole OCTOSPI bank is secure after reset.

Up to two nonsecure area can be configured through the TZSC MPCWM1 controller with a granularity of 64 Kbytes.

The OCTOSPI registers can be configured as secure through the TZSC controller.

3.23 Delay block (DLYB)

The delay block (DLYB) is used to generate an output clock dephased from the input clock. The phase of the output clock must be programmed by the user application. The output

clock is then used to clock the data received by another peripheral such as an SDMMC or Octo-SPI interface. The delay is voltage and temperature dependent, that may require the application to re-configure and recenter the output clock phase with the received data.

The delay block main features are:

- Input clock frequency ranging from 25 to 250 MHz
- Up to 12 oversampling phases

3.24 Analog-to-digital converters (ADC1, ADC2, and ADC3)

The devices embed three successive approximation analog-to-digital converters.

Table 3. ADC features

Mode/feature	ADC1	ADC2	ADC3
Resolution	12 bit		
Maximum sampling speed	5 Msps (12-bit resolution)		
Dual mode operation	X		-
Hardware offset calibration		X	
Hardware linearity calibration		-	
Single-end input		X	
Differential input	X		-
Injected channel conversion	X		-
Oversampling	Up to x256		
Data register	16 bits		
Data register FIFO depth	3 stages		
DMA support		X	
Parallel data output to ADF		-	
Offset compensation		X	
Gain compensation		-	
Number of analog watchdogs		3	

3.24.1 Analog temperature sensor

This sensor generates a voltage (V_{SENSE}) that varies linearly with temperature. It is internally connected to a comparator or to an ADC input channel used to convert the output voltage into a digital value.

The sensor provides good linearity but it must be calibrated to obtain a good accuracy of the temperature measurement. As the offset depends upon process variation, the uncalibrated internal temperature sensor is suitable for applications that detect only temperature changes.

To improve the measurement accuracy, each device is individually factory-calibrated by ST. The calibration data are stored in the system memory area, accessible in read-only mode.

3.24.2 Internal voltage reference (V_{REFINT})

The internal voltage reference (V_{REFINT}) provides a stable (bandgap) voltage output for the ADC. The V_{REFINT} is internally connected to ADC input channel.

The precise voltage of V_{REFINT} is individually measured for each part during manufacturing, and stored in the system memory area. It is accessible in read-only mode.

3.24.3 V_{BAT} battery voltage monitoring

This embedded hardware enables the application to measure the V_{BAT} battery voltage using ADC or input channel. As the V_{BAT} voltage may be higher than the V_{DDA} , and thus outside the ADC input range, the VBAT pin is internally connected to a bridge divider by four. As a consequence, the converted digital value is a quarter of the V_{BAT} voltage.

3.25 Digital temperature sensor (DTS)

The device embeds a sensor that converts the temperature into a square wave, whose frequency is proportional to the temperature. The PCLK or the LSE clock can be used as reference clock for the measurements. Use the formula given in the product reference manual to calculate the temperature according to the measured frequency stored in the DTS_DR register.

3.26 Digital to analog converter (DAC)

The DAC module is a 12-bit voltage output digital-to-analog converter. The DAC can be configured in 8- or 12-bit mode, and can be used in conjunction with the DMA controller. In 12-bit mode, the data can be left- or right-aligned.

The DAC features two output channels, each with its own converter. In dual DAC channel mode, conversions can be done independently or simultaneously when both channels are grouped together for synchronous update operations. An input reference pin, VREF+ (shared with other analog peripherals), is available for better resolution. An internal reference can also be set on the same input.

The DAC_OUTx pin can be used as general purpose input/output (GPIO) when the DAC output is disconnected from output pad and connected to on-chip peripheral. The DAC output buffer can be optionally enabled to allow a high drive output current. An individual calibration can be applied on each DAC output channel. The DAC output channels support a low power mode, the Sample and hold mode.

The digital interface supports the following features:

- One DAC interface, maximum two output channels
- Left or right data alignment in 12-bit mode
- Synchronized update capability
- Noise-wave and triangular-wave generation
- Sawtooth wave generation
- Dual DAC channel for independent or simultaneous conversions
- DMA capability for each channel including DMA underrun error detection
- Double data DMA capability to reduce the bus activity

- External triggers for conversion
- DAC output channel buffered/unbuffered modes
- Buffer offset calibration
- Each DAC output can be disconnected from the DAC_OUTx output pin
- DAC output connection to on chip peripherals
- Sample and Hold mode for low-power operation in Stop mode. The DAC voltage can be changed autonomously with the DMA while the device is in Stop mode.
- Voltage reference input

3.27 Voltage reference buffer (VREFBUF)

The devices embed a voltage reference buffer that can be used as reference for ADCs and DACs, and also as reference for external components through the VREF+ pin.

The internal voltage reference buffer supports voltages: 1.8, 2.048, and 2.5 V.

An external voltage reference can be provided through the VREF+ pin when the internal voltage reference buffer is off.

The VREF+ pin is double-bonded with VDDA on some packages. In these packages the internal voltage reference buffer is not available.

3.28 Comparators (COMP)

The devices embed two rail-to-rail comparators with programmable reference voltage (internal or external), hysteresis and speed (low speed for low power) and with selectable output polarity. The reference voltage can be one of the following:

- External I/O
- DAC output channels
- Internal reference voltage or submultiple (1/4, 1/2, 3/4)
- The analog temperature sensor
- The VBAT/4 supply.

All comparators can wake up from Stop mode, generate interrupts and breaks for the timers and can also be combined into a window comparator.

3.29 True random number generator (RNG)

The RNG is a true random number generator that provides full entropy outputs to the application as 32-bit samples. It is composed of a live entropy source (analog) and an internal conditioning component.

The RNG is a NIST SP 800-90B compliant entropy source that can be used to construct a non-deterministic random bit generator (NDRBG). It can be certified NIST SP800-90B.

The true random generator:

- delivers 32-bit true random numbers, produced by an analog entropy source conditioned by a NIST SP800-90B approved conditioning stage

- can be used as entropy source to construct a non-deterministic random bit generator (NDRBG)
- produces four 32-bit random samples every 412 AHB clock cycles if $f_{\text{AHB}} < 77$ MHz (256 RNG clock cycles otherwise)
- embeds start-up and NIST SP800-90B approved continuous health tests (repetition count and adaptive proportion tests), associated with specific error management
- can be disabled to reduce power consumption, or enabled with an automatic low-power mode (default configuration)
- has an AMBA AHB slave peripheral, accessible through 32-bit word single accesses only (else an AHB bus error is generated, and the write accesses are ignored)

3.30 HASH hardware accelerator (HASH)

The HASH is a fully compliant implementation of the secure hash (SHA-1, SHA-2 family, SHA-3 family) and the HMAC (keyed-hash message authentication code) algorithms. HMAC is suitable for applications requiring message authentication.

The HASH computes FIPS (Federal information processing standards) approved digests of length of 160, 224, 256, 512 bits, for messages of any length less than 2^{64} bits (SHA-1, SHA-224, and SHA-256) or less than 2^{128} bits (SHA-384, SHA-512).

The HASH main features are:

- Suitable for data authentication applications, compliant with:
 - FIPS PUB 180-4, *Secure Hash Standard* (SHA-1 and SHA-2 family)
 - FIPS PUB 186-4, *Digital Signature Standard* (DSS)
 - Internet Engineering Task Force (IETF) Request For Comments RFC 2104, *HMAC: Keyed-Hashing for Message Authentication* and Federal Information Processing Standards Publication FIPS PUB 198-1, *The Keyed-Hash Message Authentication Code* (HMAC)
 - Federal Information Processing Standards Publication FIPS PUB 202, *Secure Hash Standard* (SHA-3 family)
- Fast computation of SHA-1, SHA-224, SHA-256, SHA-512
 - 82 (respectively 66) clock cycles for processing one 512-bit block of data using SHA-1 (respectively SHA-256) algorithm
 - 98 clock cycles for processing one 1024-bit block of data using either SHA-384 or SHA-512 algorithm
 - Support for SHA-2 truncated outputs (SHA2-512/224, SHA2-512/256)
- Support for the six Keccak-based functions defined in FIPS 202 standard
 - Fixed output length: SHA3-224, SHA3-256, SHA3-384 and SHA3-512
 - Extendable-output functions: SHAKE128 and SHAKE256
 - One cycle per Keccak round, hence 58 cycles per 1088-bit block for SHA3-256
- Corresponding 32-bit words of the digest from consecutive message blocks are added to each other to form the digest of the whole message
 - Automatic 32-bit words swapping to comply with the internal little-endian representation of the input bit string
 - Word swapping supported: bits, bytes, half-words and 32-bit words
- Automatic padding to complete the input bit string to fit digest minimum block size

- Single 32-bit input register associated to an internal input FIFO of sixteen 32-bit words, corresponding to a 64-byte block size (16 x 32 bits)
- AHB slave peripheral, accessible through 32-bit word accesses only (else an AHB error is generated)
- 50 × 32-bit words (H0 to H41) for output message digest and general purpose SHA-3 outputs
- Automatic data flow control with support of direct memory access (DMA) using one channel. Single or fixed burst of 4 supported.
- Interruptible message digest computation, on a per-block word basis
 - Re-loadable digest registers
 - Hashing computation suspend/resume mechanism, including using DMA
- Support for HMAC mode with all supported algorithms

3.31 Public key accelerator (PKA)

The public key accelerator (PKA) can verify ECDSA signatures, with all needed computation performed within the accelerator. Application CPU is only needed to manage the inputs and the outputs of the operation.

The PKA main features are:

- ECDSA signature verification
- Capability to handle operands up to 640 bits
- AMBA AHB slave peripheral, accessible through 32-bit word single accesses only (otherwise an AHB bus error is generated, and write accesses are ignored)

3.32 Timers and watchdogs

The devices include two advanced control timers, up to six general-purpose timers, two basic timers, two low-power timers, two watchdog timers, and two SysTick timers.

Table 4 compares the features of the advanced control, general-purpose, and basic timers.

Table 4. Timer features

Type	Timer	Counter resolution	Counter type	Prescaler factor	DMA request generation	Capture/compare channels	Complementary outputs
Advanced control	TIM1, TIM8	16 bits	Up, down, up/down	Any integer between 1 and 65536	Yes	4	
General purpose	TIM2, TIM5	32 bits				4	No
	TIM3, TIM4	16 bits				4	No
General purpose	TIM12, TIM15	16 bits	Up			2	1
Basic	TIM6, TIM7	16 bits	Up			0	No

Prerelease product(s)

3.32.1 Advanced-control timers (TIM1, TIM8)

These timers can be seen as a three-phase PWM multiplexed on six channels. They have complementary PWM outputs with programmable inserted dead-times. They can also be seen as complete general-purpose timers.

The four independent channels can be used for:

- Input capture
- Output compare
- PWM generation (edge or center-aligned modes) with full modulation capability (0 - 100 %)
- One-pulse mode output

In Debug mode, the advanced-control timer counter can be frozen and the PWM outputs disabled to turn off any power switches driven by these outputs.

Many features are shared with the general-purpose TIMx timers (described in the next section) using the same architecture, so the advanced-control timers can work together with the TIMx timers via the *Timer Link* feature for synchronization or event chaining.

3.32.2 General-purpose timers (TIM2, TIM3, TIM4, TIM5, TIM15)

The devices embed up to seven synchronizable general-purpose timers (see [Table 4](#)), each of them can be used to generate PWM outputs, or act as a simple time base.

- TIM2 and TIM5

Full-featured general-purpose timers with 32-bit auto-reload up/down counter and 32-bit prescaler.

These timers feature four independent channels for input capture/output compare, PWM or one-pulse mode output. They can work together, or with the other general-purpose timers via the *Timer Link* feature for synchronization or event chaining.

The counters can be frozen in Debug mode. All have independent DMA request generation and support quadrature encoders.
- TIM3 and TIM4

Full-featured general-purpose timers, with 16-bit auto-reload up/down counter and 16-bit prescaler.

These timers feature four independent channels for input capture/output compare, PWM or one-pulse mode output.

They can work together, or with the other general-purpose timers via the *Timer Link* feature for synchronization or event chaining.

The counters can be frozen in Debug mode. All have independent DMA request generation and support quadrature encoders.
- TIM12, TIM15

General-purpose timers with mid-range features, with 16-bit auto-reload up counter and 16-bit prescaler.

 - TIM12 and TIM15 have two channels and one complementary channel

All channels can be used for input capture/output compare, PWM, or one-pulse mode output.

These timers can work together via the *Timer Link* feature for synchronization or event chaining. The timers have independent DMA request generation.

The counters can be frozen in Debug mode.

3.32.3 Basic timers (TIM6, TIM7)

These timers are mainly used for DAC trigger generation. They can also be used as generic 16-bit timebase.

3.32.4 Low-power timers (LPTIM1, LPTIM2)

The devices embed two low-power timers. These timers have an independent clock and are running in Stop mode if they are clocked by LSE, LSI or an external clock. They are able to wake up the system from Stop mode.

The low-power timers support the following features:

- 16-bit up counter with 16-bit autoreload register
- 3-bit prescaler with eight possible dividing factors (1, 2, 4, 8, 16, 32, 64, 128)
- Selectable clock
 - Internal clock sources: LSE, LSI, HSI or APB clock
 - External clock source over LPTIM input (working with no LP oscillator running, used by *Pulse Counter* application)
- 16-bit ARR autoreload register
- 16-bit capture/compare register
- Continuous/One-shot mode
- Selectable software/hardware input trigger
- Programmable digital glitch filter
- Configurable output: pulse, PWM
- Configurable I/O polarity
- Encoder mode
- Repetition counter
- Up to two independent channels for:
 - Input capture
 - PWM generation (edge-aligned mode)
 - One-pulse mode output
- Interrupt generation on ten events
- DMA request generation on the following events:
 - Update event
 - Input capture

3.32.5 Independent watchdog (IWDG)

The independent watchdog is based on a 12-bit downcounter and an 8-bit prescaler. It is clocked from an independent 32 kHz internal RC (LSI) and, as it operates independently from the main clock, it can operate in Stop and Standby modes. It can be used either as a watchdog to reset the device when a problem occurs, or as a free running timer for application timeout management. It is hardware or software configurable through the option bytes. The counter can be frozen in Debug mode.

3.32.6 Window watchdog (WWDG)

The window watchdog is based on a 7-bit downcounter that can be set as free running. It can be used as a watchdog to reset the device when a problem occurs. It is clocked from the main clock. It has an early warning interrupt capability and the counter can be frozen in Debug mode.

3.32.7 SysTick timer

The Cortex-M33 with TrustZone embeds two SysTick timers.

When TrustZone is activated, two SysTick timer are available:

- SysTick, secure instance
- SysTick, nonsecure instance

When TrustZone is disabled, only one SysTick timer is available. This timer (secure or nonsecure) is dedicated to real-time operating systems, but can also be used as a standard down counter. It features:

- A 24-bit down counter
- Autoreload capability
- Maskable system interrupt generation when the counter reaches 0
- Programmable clock source.

3.33 Real-time clock (RTC), tamper and backup registers

3.33.1 Real-time clock (RTC)

The RTC supports the following features:

- Calendar with subsecond, seconds, minutes, hours (12 or 24 format), weekday, date, month, year, in BCD (binary-coded decimal) format
- Binary mode with 32-bit free-running counter
- Automatic correction for 28, 29 (leap year), 30, and 31 days of the month
- Two programmable alarms
- On-the-fly correction from 1 to 32767 RTC clock pulses. This can be used to synchronize it with a master clock
- Reference clock detection: a more precise second source clock (50 or 60 Hz) can be used to enhance the calendar precision
- Digital calibration circuit with 0.95 ppm resolution, to compensate for quartz crystal inaccuracy
- Timestamp feature that can be used to save the calendar content. This function can be triggered by an event on the timestamp pin, or by a tamper event, or by a switch to VBAT mode
- 17-bit auto-reload wake-up timer (WUT) for periodic events with programmable resolution and period
- TrustZone support:
 - RTC fully securable
 - Alarm A, alarm B, wake-up timer and timestamp individual secure or nonsecure configuration

- Alarm A, alarm B, wake-up timer and timestamp individual privileged protection

The RTC is supplied through a switch that takes power either from the V_{DD} supply when present or from the VBAT pin.

The RTC clock sources can be one of the following:

- 32.768 kHz external crystal (LSE)
- external resonator or oscillator (LSE)
- internal low-power RC oscillator (LSI, with typical frequency of 32 kHz)
- high-speed external clock (HSE), divided by a prescaler in the RCC.

The RTC is functional in VBAT mode and in all low-power modes when it is clocked by the LSE. When clocked by the LSI, the RTC is not functional in VBAT mode, but is functional in all low-power modes.

All RTC events (alarm, wake-up timer, timestamp) can generate an interrupt and wake up the device from the low-power modes.

3.33.2 Tamper and backup registers (TAMP)

The anti-tamper detection circuit is used to protect sensitive data from external attacks. 32 32-bit backup registers are retained in all low-power modes and in VBAT mode. The backup registers, as well as other secrets in the device, are protected by this anti-tamper detection circuit with eight tamper pins and nine internal tampers. The external tamper pins can be configured for edge detection, or level detection with or without filtering, or active tamper that increases the security level by auto checking that the tamper pins are not externally opened or shorted.

TAMP main features:

- A tamper detection can erase the backup registers, backup SRAM, SRAM2, caches and cryptographic peripherals.
- 32 32-bit backup registers:
 - The backup registers (TAMP_BKPxR) are implemented in the Backup domain that remains powered-on by V_{BAT} when the V_{DD} power is switched off.
- Up to 8 tamper pins for 8 external tamper detection events:
 - Active tamper mode: continuous comparison between tamper output and input to protect from physical open-short attacks
 - Flexible active tamper I/O management: from 4 meshes (each input associated to its own exclusive output) to 7 meshes (single output shared for up to 7 tamper inputs)
 - Passive tampers: ultra-low power edge or level detection with internal pull-up hardware management
 - Configurable digital filter

Note: As input, only PC13, PA0, PA1, and PA2 are functional in Standby and VBAT modes. As output, only PC13 and PA1 are functional in Standby and VBAT modes.

- Internal tamper events to protect against transient or environmental perturbation attacks
- Each tamper can be configured in two modes:
 - Hardware mode: immediate erase of secrets on tamper detection, including backup registers erase

- Software mode: erase of secrets following a tamper detection launched by software
- Any tamper detection can generate an RTC time stamp event.
- TrustZone support:
 - Tamper secure or nonsecure configuration.
 - Backup registers configuration in three configurable-size areas:
 - 1 read/write secure area
 - 1 write secure/read nonsecure area
 - 1 read/write nonsecure area
- Tamper configuration and backup registers privilege protection
- Monotonic counter

3.34 Inter-integrated circuit interface (I2C)

The devices embed three I2Cs.

The I²C bus interface handles communications between the microcontroller and the serial I²C bus. It controls all I²C bus-specific sequencing, protocol, arbitration and timing.

The I2C peripheral supports:

- I²C-bus specification and user manual rev. 5 compatibility:
 - Target and controller modes, multicontroller capability
 - Standard-mode (Sm), with a bit rate up to 100 Kbit/s
 - Fast-mode (Fm), with a bit rate up to 400 Kbit/s
 - Fast-mode Plus (Fm+), with a bit rate up to 1 Mbit/s and 20 mA output drive I/Os
 - 7- and 10-bit addressing modes, multiple 7-bit target addresses
 - Programmable setup and hold times
 - Optional clock stretching
- System management bus (SMBus) specification rev 3.0 compatibility:
 - Hardware PEC (packet error checking) generation and verification with ACK control
 - Address resolution protocol (ARP) support
 - SMBus alert
- Power system management protocol (PMBus) specification rev 1.3 compatibility
- Independent clock: a choice of independent clock sources makes the I2C communication speed independent from the PCLK reprogramming
- Wake-up from Stop capability
- Programmable analog and digital noise filters
- 1-byte buffer with DMA capability

Table 5. I2C implementation

Feature ⁽¹⁾	I2C1	I2C2	I2C3
Standard-mode (up to 100 Kbit/s)	X	X	X
Fast-mode (up to 400 Kbit/s)	X	X	X

Table 5. I2C implementation (continued)

Feature ⁽¹⁾	I2C1	I2C2	I2C3
Fast-mode Plus with 20 mA output drive I/Os (up to 1 Mbit/s)	X	X	X
Programmable analog and digital noise filters	X	X	X
SMBus/PMBus hardware support	X	X	X
Independent clock	X	X	X
Wake-up capability	X	X	X

1. X: supported

3.35 Improved inter-integrated circuit (I3C)

The I3C interface handles communication between the MCU and others, like sensors and host processor(s), all connected on an I3C bus.

The peripheral implements the required features of the MIPI I3C specification v1.1. It can control I3C bus-specific sequencing, protocol, arbitration and timing, and can act as controller (formerly known as master) or as target (formerly known as slave). When acting as controller, the peripheral improves the features of the I2C interface, preserving some backward compatibility. It allows an I2C target to operate on an I3C bus in legacy I2C fast-mode (Fm) or legacy I2C fast-mode plus (Fm+), provided that the latter does not perform clock stretching.

After reset, the software can initialize the I3C peripheral as primary controller or as target:

- As controller, the software can enable the peripheral and initialize the I3C bus.
- As target, the software can enable the peripheral to operate on an I3C or an I2C bus, provided that the I2C bus is restricted to the I2C sub-features compliant with a MIPI I3C bus protocol:
 - Only Sm, Fm or Fm+ speed
 - No clock stretching
 - No multiple 7-bit addresses
 - No general call message
 - No 10-bit addressing
 - No SMBus

The I3C peripheral can be used with DMA to off-load the CPU.

Prerelease product(s)

Table 6. I3C peripheral controller/target features versus MIPI v1.1

Feature	MIPI v1.1	When controller	When target	Comments
I3C SDR message	X	X	X	-
Legacy I ² C message (Fm/Fm+)	X	X		Mandatory when controller, and the I3C bus is mixed with (external) legacy I ² C target(s). Optional in MIPI v1.1 when target. Supported when target on an I2C or an I3C bus.
HDR DDR message	X	-	-	Optional in MIPI v1.1
HDR-TSL/TSP, HDR-BT	X	-	-	
Static address	X	X	X	Supported when target on an I2C bus. Can be used during the initialization phase when target on an I3C bus.
Grouped addressing	X	X	-	Optional in MIPI v1.1
CCCs	X	X	X	Mandatory and some optional CCCs supported
Error detection and recovery	X	X	X	-
In-band interrupt (with MDB)	X	X	X	-
Secondary controller	X	X	X	-
Hot-join mechanism	X	X	X	-
Target reset	X	X	X	-
Synchronous timing control	X	X	-	Optional in MIPI v1.1
Asynchronous timing control 0	X	X	-	Mandatory in MIPI v1.1 when controller, optional when target
Asynchronous timing control 1, 2, 3	X	-	-	Optional in MIPI v1.1
Device to device tunneling	X	X	-	
Multi-lane data transfer	X	-	-	
Monitoring device early termination	X	-	-	

3.36 Universal synchronous/asynchronous receiver transmitter (USART/UART) and low-power universal asynchronous receiver transmitter (LPUART)

The devices embed four universal synchronous receiver transmitters (USART1/USART2/USART3/USART6), four universal asynchronous receiver transmitters (UART4/UART5/UART7/UART8), one low-power universal asynchronous receiver transmitter (LPUART1).

Table 7. USART, UART and LPUART features

Mode/feature ⁽¹⁾	USART1/2/3/6	UART4/5/7/8	LPUART1
Hardware flow control for modem	X	X	X
Continuous communication using DMA	X	X	X

Table 7. USART, UART and LPUART features (continued)

Mode/feature ⁽¹⁾	USART1/2/3/6	UART4/5/7/8	LPUART1
Multiprocessor communication	X	X	X
Synchronous mode (master/slave)	X	-	-
Smartcard mode	X	-	-
Single-wire half-duplex communication	X	X	X
IrDA SIR ENDEC block	X	X	-
LIN mode	X	X	-
Dual-clock domain and wake-up from Stop mode	X ⁽²⁾	X ⁽²⁾	X ⁽²⁾
Receiver timeout interrupt	X	X	-
Modbus communication	X	X	-
Auto-baud rate detection	X	X	-
Driver enable	X	X	X
USART data length	7, 8, and 9 bits		
Tx/Rx FIFO	X	X	X
Tx/Rx FIFO size	8 bytes		

1. X = supported.
2. Wake-up supported from Stop mode.

3.36.1 Universal synchronous/asynchronous receiver transmitter (USART/UART)

The USART offers a flexible means to perform full-duplex data exchange with external equipments requiring an industry standard NRZ asynchronous serial data format. A very wide range of baud rates can be achieved through a fractional baud rate generator.

The USART supports both synchronous one-way and half-duplex single-wire communications, as well as LIN (local interconnection network), Smartcard protocol, IrDA (infrared data association) SIR ENDEC specifications, and modem operations (CTS/RTS). Multiprocessor communications are also supported.

High-speed data communication (up to 20 Mbauds) is possible by using the DMA (direct memory access) for multibuffer configuration.

The USART main features are:

- Full-duplex asynchronous communication
- NRZ standard format (mark/space)
- Configurable oversampling method by 16 or by 8, to achieve the best compromise between speed and clock tolerance
- Baud rate generator systems
- Two internal FIFOs for transmit and receive data
Each FIFO can be enabled/disabled by software and come with a status flag.
- A common programmable transmit and receive baud rate
- Dual-clock domain with dedicated kernel clock for peripherals independent from PCLK
- Auto baud rate detection

- Programmable data word length (7, 8 or 9 bits)
- Programmable data order with MSB-first or LSB-first shifting
- Configurable stop bits (1 or 2 stop bits)
- Synchronous Master/Slave mode and clock output/input for synchronous communications
- SPI slave transmission underrun error flag
- Single-wire half-duplex communications
- Continuous communications using DMA
- Received/transmitted bytes are buffered in reserved SRAM using centralized DMA
- Separate enable bits for transmitter and receiver
- Separate signal polarity control for transmission and reception
- Swappable Tx/Rx pin configuration
- Hardware flow control for modem and RS-485 transceiver
- Communication control/error detection flags
- Parity control:
 - Transmits parity bit
 - Checks parity of received data byte
- Interrupt sources with flags
- Multiprocessor communications: wake-up from Mute mode by idle line detection or address mark detection
- Autonomous functionality in Stop mode with wake-up from stop capability
- LIN master synchronous break send capability and LIN slave break detection capability
 - 13-bit break generation and 10/11-bit break detection when USART is hardware configured for LIN
- IrDA SIR encoder decoder supporting 3/16 bit duration for Normal mode
- Smartcard mode
 - Supports the T = 0 and T = 1 asynchronous protocols for smartcards as defined in the ISO/IEC 7816-3 standard
 - 0.5 and 1.5 stop bits for Smartcard operation
- Support for Modbus communication
 - Timeout feature
 - CR/LF character recognition

3.36.2 Low-power universal asynchronous receiver transmitter (LPUART)

The LPUART supports bidirectional asynchronous serial communication with minimum power consumption. It also supports half-duplex single-wire communication and modem operations (CTS/RTS). It allows multiprocessor communication.

Only a 32.768 kHz clock (LSE) is needed to allow LPUART communication up to 9600 baud. Therefore, even in Stop mode, the LPUART can wait for an incoming frame while having an extremely low energy consumption. Higher-speed clock can be used to reach higher baud-rates.

The LPUART interface can be served by the DMA controller.

The LPUART main features are:

- Full-duplex asynchronous communications
- NRZ standard format (mark/space)
- Programmable baud rate
- From 300 to 9600 bauds using a 32.768 kHz clock source
- Higher baud rates can be achieved by using a higher frequency clock source
- Two internal FIFOs to transmit and receive data
Each FIFO can be enabled/disabled by software and come with status flags for FIFOs states.
- Dual-clock domain with dedicated kernel clock for peripherals independent from PCLK
- Programmable data word length (7 or 8 or 9 bits)
- Programmable data order with MSB-first or LSB-first shifting
- Configurable stop bits (1 or 2 stop bits)
- Single-wire half-duplex communications
- Continuous communications using DMA
- Received/transmitted bytes are buffered in reserved SRAM using centralized DMA
- Separate enable bits for transmitter and receiver
- Separate signal polarity control for transmission and reception
- Swappable Tx/Rx pin configuration
- Hardware flow control for modem and RS-485 transceiver
- Transfer detection flags:
 - Receive buffer full
 - Transmit buffer empty
 - Busy and end of transmission flags
- Parity control:
 - Transmits parity bit
 - Checks parity of received data byte
- Four error detection flags:
 - Overrun error
 - Noise detection
 - Frame error
 - Parity error
- Interrupt sources with flags
- Multiprocessor communications: wake-up from Mute mode by idle line detection or address mark detection
- Wake-up from Stop capability

3.37 Serial peripheral interface (SPI) / inter-integrated sound interface (I2S)

The devices embed four serial peripheral interfaces (SPI) that can be used to communicate with external devices while using the specific synchronous protocol. The SPI protocol supports half-duplex, full-duplex and simplex synchronous, serial communication with external devices.

The interface can be configured as master or slave, and can operate in multi-slave or multi-master configurations. The device configured as master provides communication clock (SCK) to the slave device. The slave select (SS) and ready (RDY) signals can be applied optionally just to set up communication with concrete slave and to assure it handles the data flow properly. The Motorola data format is used by default, but some other specific modes are supported as well.

The SPI main features are:

- Full-duplex synchronous transfers on three lines
- Half-duplex synchronous transfer on two lines (with bidirectional data line)
- Simplex synchronous transfers on two lines (with unidirectional data line)
- 4-bit to 32-bit data size selection or fixed to 8-bit and 16-bit only
- Multi master or multi slave mode capability
- Dual-clock domain, separated clock for the peripheral kernel that can be independent of PCLK
- Baud rate prescaler up to kernel frequency divided by 2 or bypass from RCC in Master mode
- Protection of configuration and setting
- Hardware or software management of SS for both master and slave
- Adjustable minimum delays between data and between SS and data flow
- Configurable SS signal polarity and timing, MISO x MOSI swap capability
- Programmable clock polarity and phase
- Programmable data order with MSB-first or LSB-first shifting
- Programmable number of data within a transaction to control SS and CRC
- Dedicated transmission and reception flags with interrupt capability
- SPI Motorola and TI formats support
- Hardware CRC feature can secure communication at the end of transaction by:
 - Adding CRC value in Tx mode
 - Automatic CRC error checking for Rx mode
- Error detection with interrupt capability in case of data overrun, CRC error, data underrun at slave, mode fault at master
- Two 16x or 8x 8-bit embedded Rx and Tx FIFOs with DMA capability
- Programmable number of data in transaction
- Configurable FIFO thresholds (data packing)
- Configurable behavior at slave underrun condition (support of cascaded circular buffers)
- Wake-up from Stop capability
- Optional status pin RDY signaling the slave device ready to handle the data flow.

Three standard I2S interfaces (multiplexed with SPI1, SPI2 and SPI3) are available. They can be operated in Master or Slave mode, in full-duplex communication modes, and can be configured to operate with configurable resolution as input or output channel.

I2S main features:

- Full duplex communication
- Simplex communication (only transmitter or receiver)
- Master or slave operations
- 8-bit programmable linear prescaler
- Data length may be 16, 24 or 32 bits
- Channel length can be 16 or 32 in master, any value in slave
- Programmable clock polarity
- Error flags signaling for improved reliability: Underrun, Overrun, and Frame Error
- Embedded Rx and Tx FIFOs
- Supported I2S protocols:
 - I2S Philips standard
 - MSB-Justified standard (left-justified)
 - LSB-Justified standard (right-justified)
 - PCM standard (with short and long frame synchronization)
- Data ordering programmable (LSb or MSb first)
- DMA capability for transmission and reception
- Master clock can be output to drive an external audio component. The ratio is fixed at 256 x FWS (where FWS is the audio sampling frequency)

Table 8. SPI features

Feature	SPI1, SPI2, SPI3 (full feature set instances)
Data size	Configurable from 4 to 32-bit
CRC computation	CRC polynomial length configurable from 5 to 33-bit
Size of FIFOs	16x 8-bit
Number of transferred data	Unlimited, expandable
I2S feature	Yes

3.38 Secure digital input/output and MultiMediaCards interface (SDMMC)

The SD/SDIO, embedded MultiMediaCard (eMMC™) host interface (SDMMC) provides an interface between the AHB bus and SD memory cards, SDIO cards, and eMMC devices.

The MultiMediaCard system specifications are available through the MultiMediaCard association website at www.mmca.org, published by the MMCA technical committee.

SD memory card and SD I/O card system specifications are available through the SD card association website at www.sdcard.org.

The SDMMC features include the following:

- Compliance with Embedded MultiMediaCard System Specification Version 5.1

- Card support for three different databus modes: 1-bit (default), 4-bit and 8-bit (HS200 SDMMC_CK speed limited to maximum allowed I/O speed, HS400 is not supported).
- Full compatibility with previous versions of MultiMediaCards (backward compatibility).
- Full compliance with SD memory card specifications version 6.0 (SDR104 SDMMC_CK speed limited to maximum allowed I/O speed, SPI mode and UHS-II mode not supported).
- Full compliance with SDIO card specification version 4.0
- Card support for two different databus modes: 1-bit (default) and 4-bit (SDR104 SDMMC_CK speed limited to maximum allowed I/O speed, SPI mode and UHS-II mode not supported).
- Data transfer up to 208 Mbyte/s for the 8-bit mode, depending maximum allowed I/O speed.
- Data and command output enable signals to control external bidirectional drivers
- IDMA linked list support

The MultiMediaCard/SD bus connects cards to the host.

The current version of the SDMMC supports only one SD/SDIO/eMMC card at any one time and a stack of eMMC.

Table 9. SDMMC features

Mode/feature ⁽¹⁾	SDMMC1
Variable delay (SDR104, HS200)	X
SDMMC_CKIN	X
SDMMC_CDIR, SDMMC_D0DIR	X
SDMMC_D123DIR	X

1. X = supported.

3.39 Controller area network (FDCAN)

The controller area network (CAN) subsystem consists of one CAN module, a shared message RAM memory and a configuration block.

The modules (FDCAN) are compliant with ISO 11898-1: 2015 (CAN protocol specification version 2.0 part A, B) and CAN FD protocol specification version 1.0.

A 0.8-Kbyte message RAM implements filters, receives FIFOs, transmits event FIFOs, and transmits FIFOs.

The FDCAN main features are:

- Conform with CAN protocol version 2.0 part A, B and ISO 11898-1: 2015, -4
- CAN FD with maximum 64 data bytes supported
- CAN error logging
- AUTOSAR and J1939 support
- Improved acceptance filtering
- Two receive FIFOs of three payloads each (up to 64 bytes per payload)
- Separate signaling on reception of high priority messages

- Configurable transmit FIFO / queue of three payload (up to 64 bytes per payload)
- Configurable transmit Event FIFO
- Programmable loop-back test mode
- Maskable module interrupts
- Two clock domains: APB bus interface and CAN core kernel clock
- Power-down support

3.40 USB full speed (USB)

USB main features:

- USB specification version 2.0 full-speed compliant
- Host and device functions
- 2048 bytes of dedicated SRAM data buffer memory with 32-bit access
- USB clock recovery
- Configurable number of endpoints from 1 to 8
- Cyclic redundancy check (CRC) generation/checking, non-return-to-zero inverted (NRZI) encoding/decoding and bit-stuffing
- Isochronous transfers support
- Double-buffered bulk/isochronous endpoint support
- USB suspend/resume operations
- Frame-locked clock pulse generation
- USB 2.0 Link power management support
- Battery charging specification revision 1.2 support in device

3.41 USB Type-C/USB power delivery controller (UCPD)

The devices embed one controller (UCPD) compliant with USB Type-C Cable and Connector Specification release 2.4 and USB Power Delivery Rev. 3.0 specifications.

The controller uses specific I/Os supporting the USB Type-C and USB power delivery requirements, featuring:

- USB Type-C pull-up (R_p , all values) and pull-down (R_d) resistors
- “Dead battery” support
- USB power delivery message transmission and reception
- FRS (fast role swap) support

The digital controller handles:

- USB Type-C level detection with debounce, generating interrupts
- FRS detection, generating an interrupt
- Byte-level interface for USB power delivery payload, generating interrupts (DMA compatible)
- USB power delivery timing dividers (including a clock pre-scaler)
- CRC generation/checking
- 4b5b encode/decode

- Ordered sets (with a programmable ordered set mask at receive)
- Frequency recovery in receiver during preamble

The interface offers low-power operation compatible with Stop mode, maintaining the capacity to detect incoming USB power delivery messages and FRS signaling.

3.42 Ethernet MAC interface with dedicated DMA controller (ETH)

The devices provide an IEEE-802.3-2002-compliant media access controller (MAC) for Ethernet LAN communications through an industry-standard medium-independent interface (MII) or a reduced medium-independent interface (RMII). The microcontroller requires an external physical interface device (PHY) such as twisted-pair or fiber to connect to the physical LAN bus. The PHY is connected to the device MII port using 17 signals for MII or 9 signals for RMII, and can be clocked using the 25 MHz (MII) from the microcontroller.

The devices include the following features:

- Support of 10 and 100 Mbit/s rates
- Dedicated DMA controller allowing high-speed transfers between the dedicated SRAM and the descriptors
- Tagged MAC frame support (VLAN support)
- Half-duplex (CSMA/CD) and full-duplex operation
- MAC control sublayer (control frames) support
- 32-bit CRC generation and removal
- Several address filtering modes for physical and multicast address (multicast and group addresses)
- 32-bit status code for each transmitted or received frame
- Internal 2-Kbyte FIFOs to buffer transmit and receive frames
- Support of hardware PTP (precision time protocol) in accordance with IEEE 1588 2008 (PTP V2) with the time stamp comparator connected to the TIM2 input
- Trigger of interrupt when system time becomes greater than target time

3.43 High-definition multimedia interface (HDMI) - consumer electronics control (CEC)

The devices embed an HDMI-CEC controller that provides hardware support for the Consumer Electronics Control (CEC) protocol (Supplement 1 to the HDMI standard).

This protocol provides high-level control functions between all audiovisual products in an environment. It is specified to operate at low speeds with minimum processing and memory overhead. It has a clock domain independent from the CPU clock, allowing the HDMI-CEC controller to wake up the MCU from Stop mode on data reception.

3.44 Development support

3.44.1 Serial-wire/JTAG debug port (SWJ-DP)

The Arm SWJ-DP interface is embedded and is a combined JTAG and serial-wire debug port that enables either a serial wire debug or a JTAG probe to be connected to the target.

Debug is performed using two pins only instead of five required by the JTAG (JTAG pins can be re-used as GPIO with alternate function): the JTAG TMS and TCK pins are shared with SWDIO and SWCLK, respectively, and a specific sequence on the TMS pin is used to switch between JTAG-DP and SW-DP.

3.44.2 Embedded Trace Macrocell

The Arm Embedded Trace Macrocell (ETM) provides a greater visibility of the instruction and data flow inside the CPU core by streaming compressed data at a very high rate from the devices through a small number of ETM pins to an external hardware trace port analyzer (TPA) device.

Real-time instruction and data flow activity be recorded and then formatted for display on the host computer that runs the debugger software. TPA hardware is commercially available from common development tool vendors.

The ETM operates with third party debugger software tools.

4 Pinout, pin description, and alternate functions

4.1 Pinout/ballout schematics

Figure 5. LQFP48 pinout

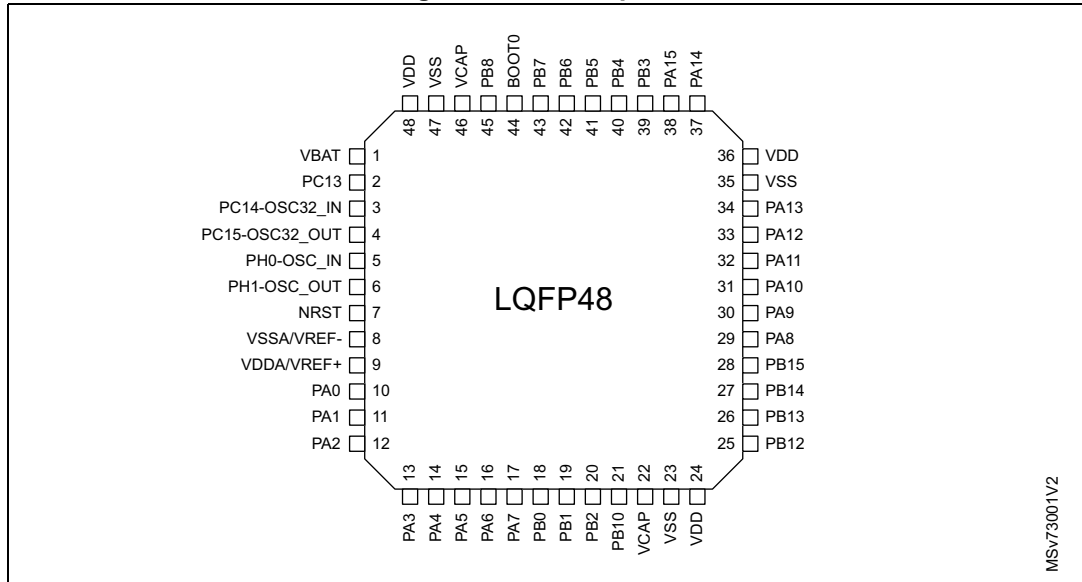

1. The above figure shows the package top view.

Figure 6. UFQFPN48 pinout

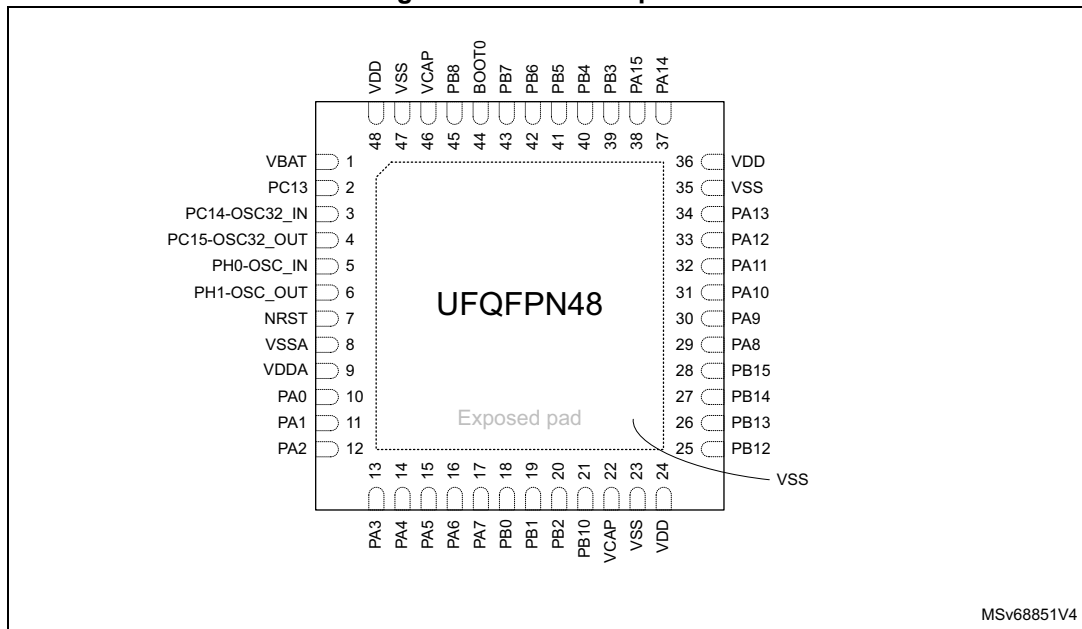

1. The above figure shows the package top view.

Prerelease product(s)

Figure 7. WLCSP63 ballout

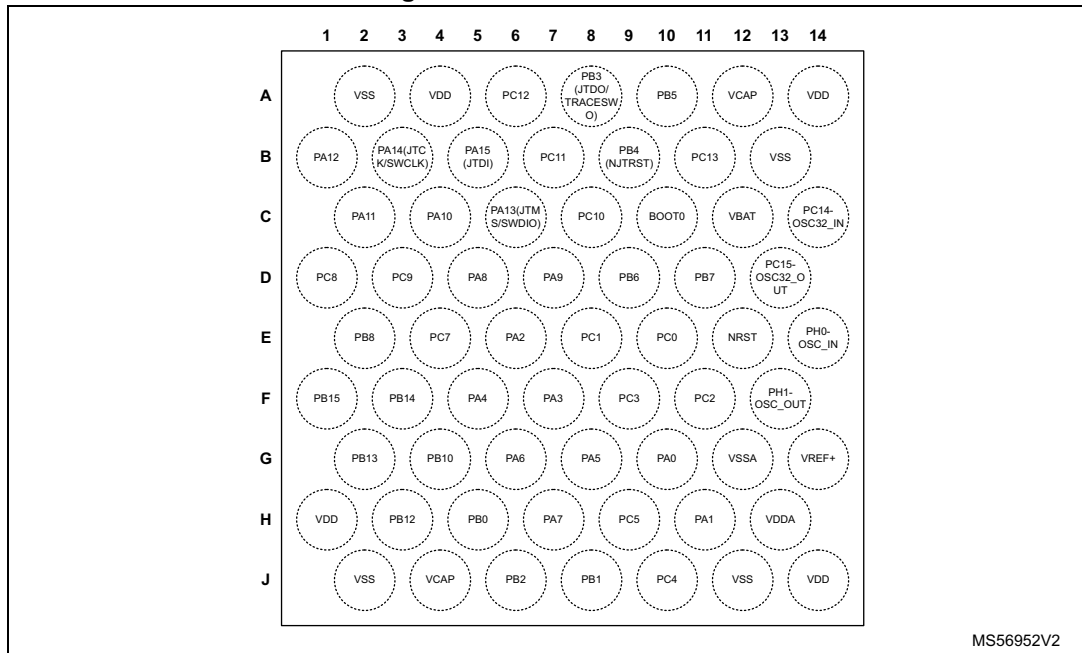

MS56952V2

1. The above figure shows the package top view.

Figure 8. LQFP64 pinout

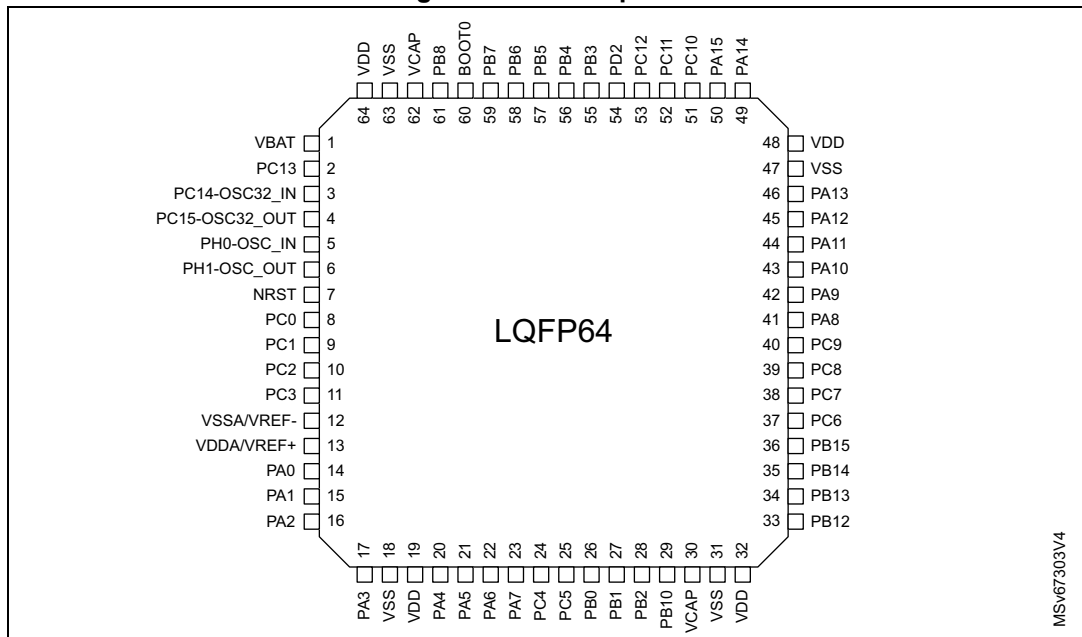

MSv67303V4

1. The above figure shows the package top view.

Prerelease product(s)

Figure 9. LQFP100 pinout

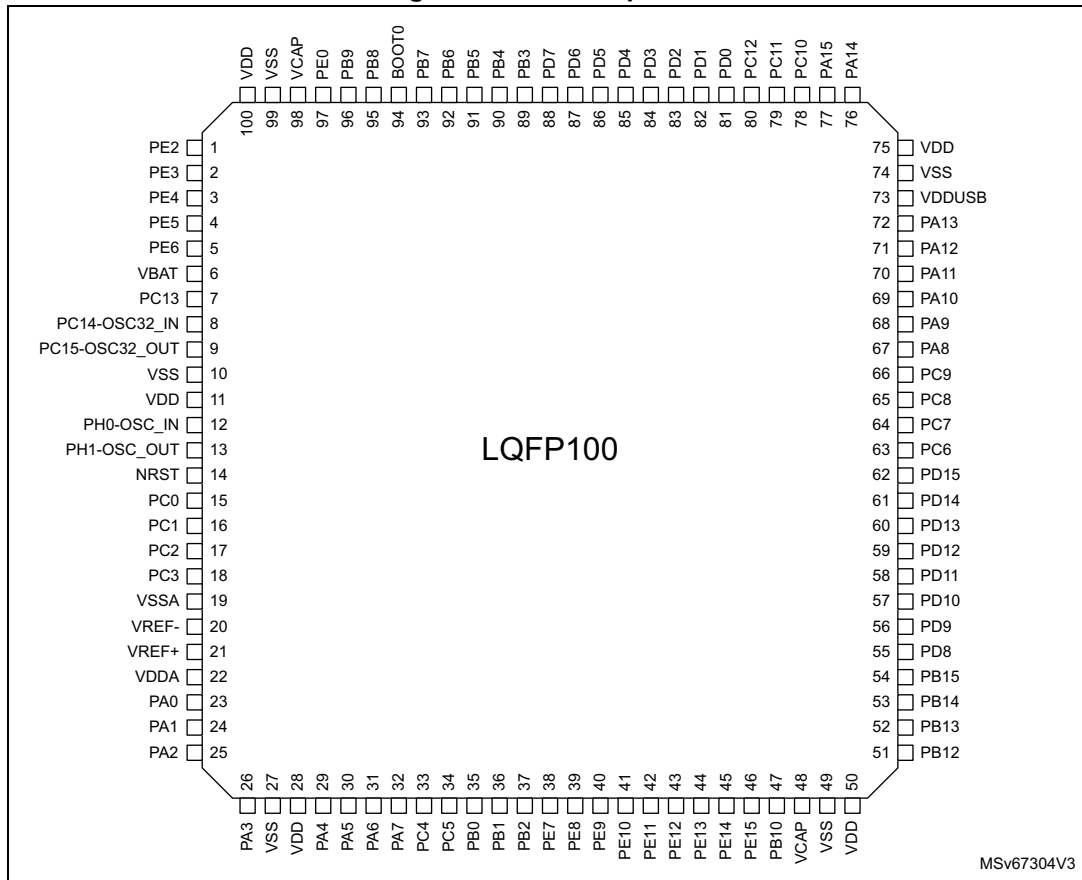

1. The above figure shows the package top view.

Prerelease product(s)

Figure 10. LQFP100-EP pinout

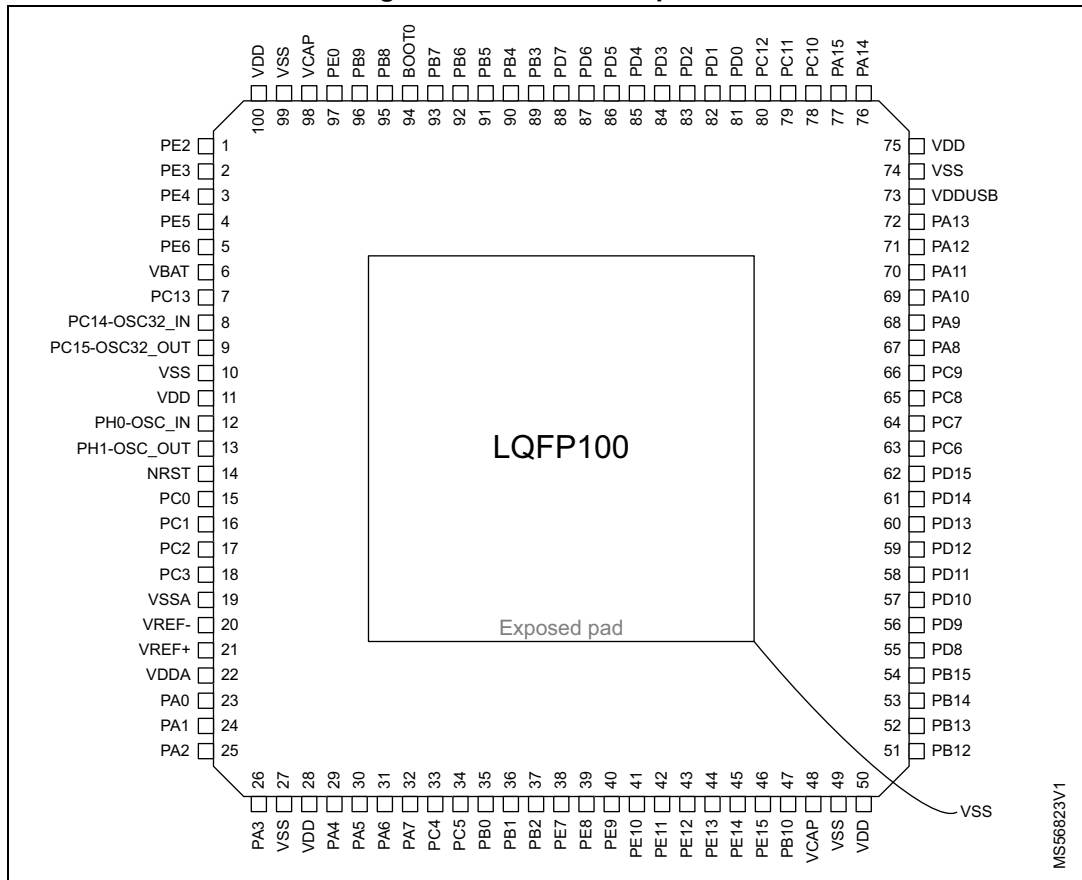

1. The above figure shows the package top view.

Figure 11. UFBGA100 ballout

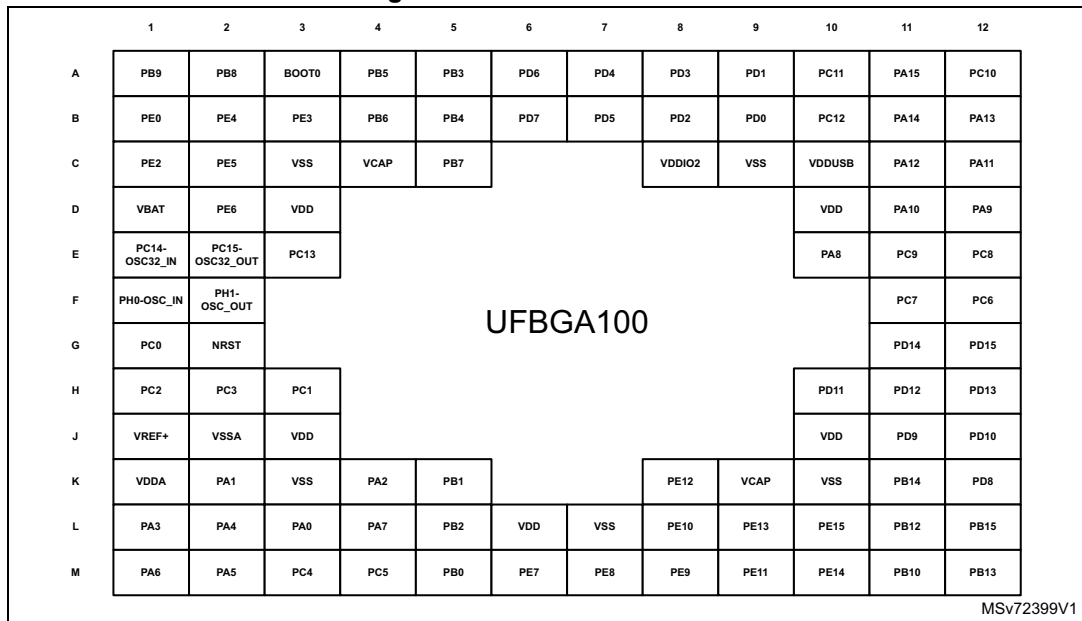

1. The above figure shows the package top view.

Prerelease product(s)

Figure 12. LQFP144 pinout

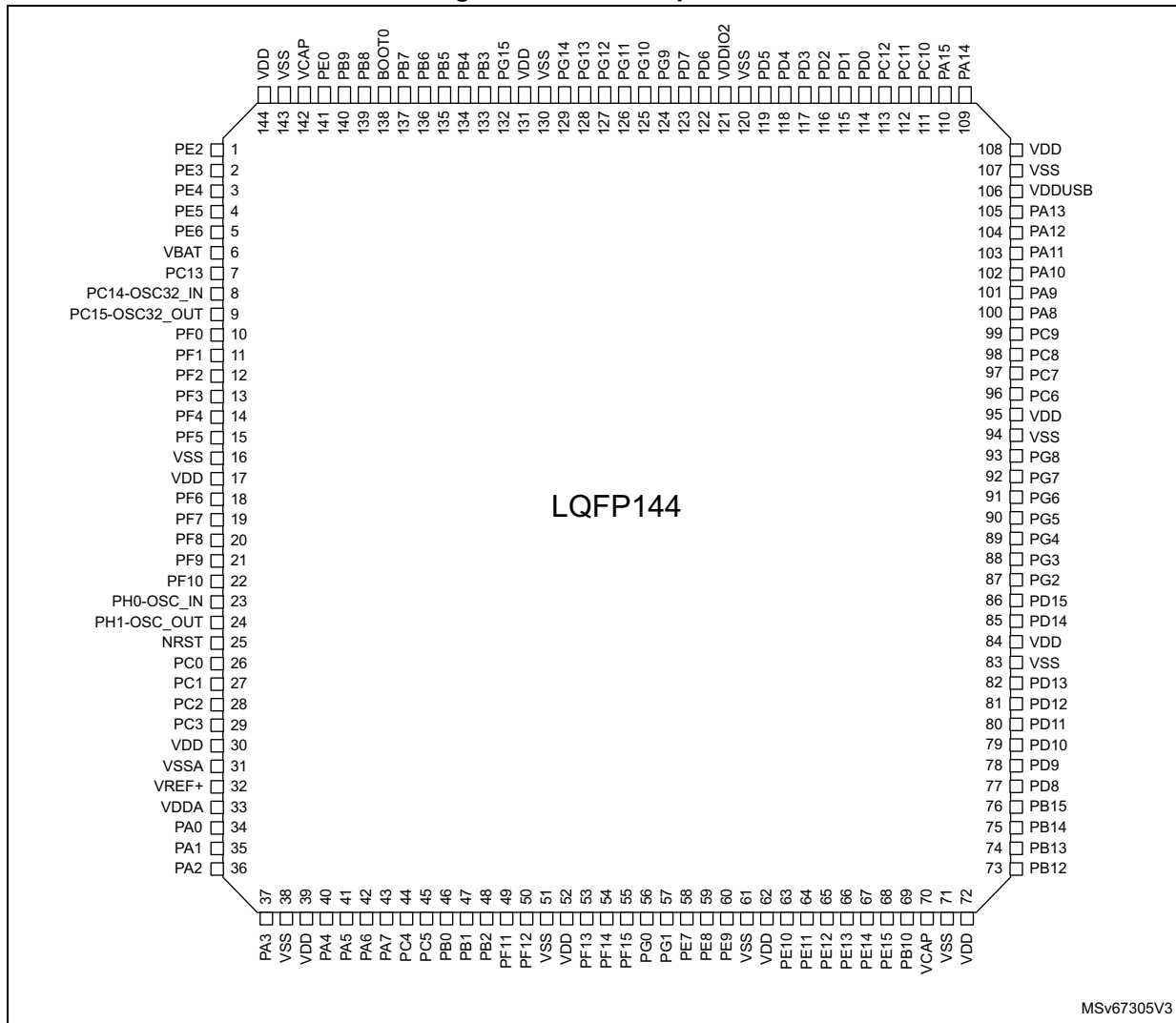

MSv67305V3

1. The above figure shows the package top view.

Prerelease product(s)

Figure 13. LQFP144-EP pinout

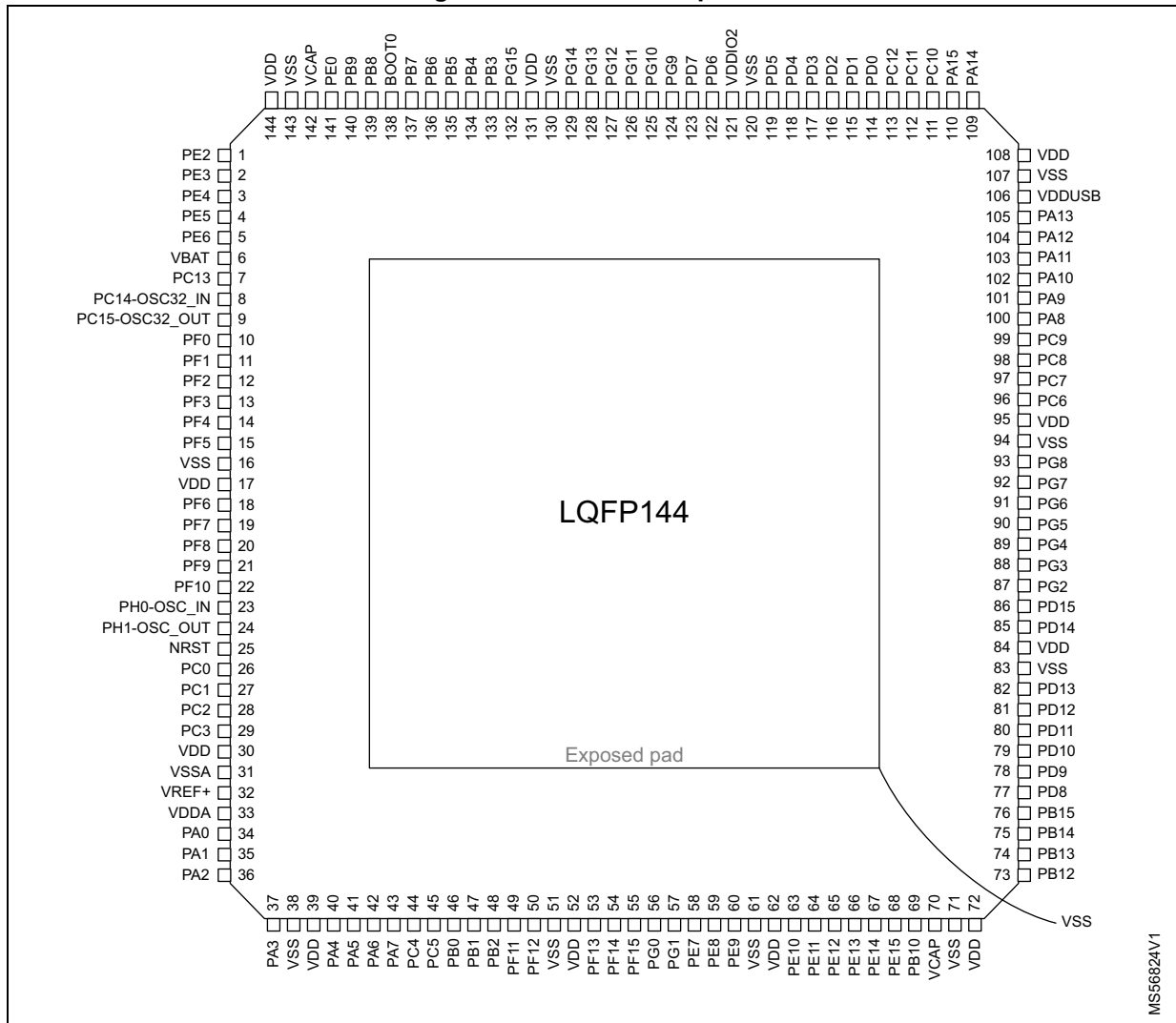

1. The above figure shows the package top view.

Prerelease product(s)

MS56824V1

Figure 14. UFBGA144 ballout

	1	2	3	4	5	6	7	8	9	10	11	12
A	VSS	PB9	PB7	PB4	PG15	PG12	PG11	PD7	PD4	PD2	PC10	VSS
B	PE2	PE0	PB8	PB6	PB3	PG14	PG10	PD6	PD3	PC12	PA14	PA10
C	VBAT	PE4	PE3	BOOT0	VDDIO2	VSS	VDDIO2	PD5	PD1	VDDUSB	PA12	PA11
D	PC15- OSC32_OUT	PC14- OSC32_IN	PE5	VSS	VCAP	PG13	PG9	PD0	PC11	VSS	PA9	PA8
E	PF1	PF0	PC13	PE6	VDD	PB5	VDD	PA15	PA13	PC9	PC8	PC7
F	PF5	PF4	PF3	PF2	VSS	VDD	VSS	VDD	PC6	PG8	PG7	PG6
G	PF6	PF7	PF9	PF8	VDD	VSS	VDD	PD11	PD15	PG3	PG4	PG5
H	PH0- OSC_IN	PH1- OSC_OUT	PF10	VREF-	VSS	VDD	VSS	PB14	PB15	PD12	PD14	PG2
J	NRST	PC0	VREF+	VDDA	PA7	PB1	PG1	VCAP	VSS	PD8	PD9	PD13
K	PC2	PC1	VSSA	PA2	PC4	PB2	PF15	PE9	PE12	PE15	PB13	PD10
L	PC3	PA0	PA1	PA5	PC5	PF11	PF14	PE7	PE10	PE14	PB10	PB12
M	VSS	PA3	PA4	PA6	PB0	PF12	PF13	PG0	PE8	PE11	PE13	VSS

MS56798V1

1. The above figure shows the package top view.

Prerelease product(s)

4.2 Pin description

Table 10. Legend/abbreviations used in the pinout table

Name	Abbreviation	Definition
Pin name	Unless otherwise specified in brackets below the pin name, the pin function during and after reset is the same as the actual pin name	
Pin type	S	Supply pin
	I	Input only pin
	I/O	Input/output pin
I/O structure	FT	5 V-tolerant I/O
	TT	3.6 V-tolerant I/O
	RST	Bidirectional reset pin with embedded weak pull-up resistor
	Option for TT or FT I/Os⁽¹⁾	
	_a	I/O, with analog switch function supplied by V _{DDA}
	_c	I/O with USB Type-C power delivery function
	_d	I/O with USB Type-C power delivery dead battery function
	_f	I/O, Fm+ capable
	_h	I/O with high-speed low-voltage mode
	_s	I/O supplied only by V _{DDIO2}
	_t	I/O with tamper function functional in VBAT mode
_u	I/O, with USB function supplied by V _{DDUSB}	
Notes	Unless otherwise specified by a note, all I/Os are set as analog inputs during and after reset	
Pin functions	Alternate functions	Functions selected through GPIOx_AFR registers
	Additional functions	Functions directly selected/enabled through peripheral registers

1. The related I/O structures in the following table are a concatenation of various options. Examples: FT_hat, FT_fs, FT_u, TT_a.

Prerelease product(s)



Table 11. STM32H543xx pin/ball definition

Pin Number										Pin name (function after reset)	Pin type	I/O structure	Notes	Alternate functions	Additional functions
LQFP48	UFQFPN48	WLCSP63	LQFP64	LQFP100-EP	LQFP100	UFBGA100	LQFP144-EP	LQFP144	UFBGA144						
-	-	-	-	1	1	C1	1	1	B1	PE2	I/O	FT_h	-	TRACECLK, LPTIM1_IN2, SPI4_SCK, UART8_TX, OCTOSPI1_IO2, ETH_MII_TXD3, FMC_A23, PLAY1_OUT15, EVENTOUT	-
-	-	-	-	2	2	B3	2	2	C3	PE3	I/O	FT_h	-	TRACED0, TIM15_BKIN, FMC_A19, PLAY1_IN7, EVENTOUT	TAMP_IN6/TAMP_OUT3
-	-	-	-	3	3	B2	3	3	C2	PE4	I/O	FT_h	-	TRACED1, TIM15_CH1N, SPI4_NSS, ETH_10BT1S_RX, ETH_MII_RXD0/ETH_B10T1S_RX_IN/ETH_RMII_RXD0, FMC_A20, UART8_TX, PLAY1_OUT7, EVENTOUT	TAMP_IN7/TAMP_OUT8
-	-	-	-	4	4	C2	4	4	D3	PE5	I/O	FT_h	-	TRACED2, TIM15_CH1, SPI4_MISO, ETH_MII_RXD1/ETH_RMII_RXD1, FMC_A21, UART8_RX, PLAY1_OUT8, EVENTOUT	TAMP_IN8/TAMP_OUT7
-	-	-	-	5	5	D2	5	5	E4	PE6	I/O	FT_h	-	TRACED3, TIM1_BKIN2, TIM15_CH2, SPI4_MOSI, FMC_A22, PLAY1_IN14, EVENTOUT	TAMP_IN3/TAMP_OUT6
-	-	A4	-	-	-	D3	-	-	E5	VDD	S	-	-	-	-
-	-	A2	-	-	-	C3	-	-	A1	VSS	S	-	-	-	-
1	1	C12	1	6	6	D1	6	6	C1	VBAT	S	-	-	-	-
-	-	B13	-	-	-	C9	-	-	A12	VSS	S	-	-	-	-
2	2	B11	2	7	7	E3	7	7	E3	PC13	I/O	FT_t	-	EVENTOUT	TAMP_IN1/TAMP_OUT2/TAMP_OUT3, RTC_OUT1/RTC_TS, WKUP4
-	-	J2	-	-	-	K3	-	-	C6	VSS	S	-	-	-	-
3	3	C14	3	8	8	E1	8	8	D2	PC14-OSC32_IN(OSC32_IN)	I/O	FT	-	EVENTOUT	OSC32_IN
4	4	D13	4	9	9	E2	9	9	D1	PC15-OSC32_OUT(OSC32_OUT)	I/O	FT	-	EVENTOUT	OSC32_OUT
-	-	-	-	-	-	-	10	10	E2	PF0	I/O	FT_f	-	I3C2_SDA, I2C2_SDA, FMC_A0, EVENTOUT	-
-	-	-	-	-	-	-	11	11	E1	PF1	I/O	FT_f	-	I3C2_SCL, I2C2_SCL, FMC_A1, EVENTOUT	-
-	-	-	-	-	-	-	12	12	F4	PF2	I/O	FT_h	-	I2C2_SMBA, FMC_A2, EVENTOUT	-



Table 11. STM32H543xx pin/ball definition (continued)

Pin Number										Pin name (function after reset)	Pin type	I/O structure	Notes	Alternate functions	Additional functions
LQFP48	UFQFPN48	WLSP63	LQFP64	LQFP100-EP	LQFP100	UFBGA100	LQFP144-EP	LQFP144	UFBGA144						
-	-	-	-	-	-	-	13	13	F3	PF3	I/O	FT_h	-	FMC_A3, EVENTOUT	-
-	-	-	-	-	-	-	14	14	F2	PF4	I/O	FT_h	-	FMC_A4, EVENTOUT	-
-	-	-	-	-	-	-	15	15	F1	PF5	I/O	FT_h	-	I3C1_SCL, FMC_A5, EVENTOUT	-
-	-	J12	-	10	10	K10	16	16	D4	VSS	S	-	-	-	-
-	-	A14	-	11	11	D10	17	17	E7	VDD	S	-	-	-	-
-	-	-	-	-	-	-	18	18	G1	PF6	I/O	FT_h	-	UART7_RX, OCTOSPI1_IO3, FMC_NBL1, EVENTOUT	-
-	-	-	-	-	-	-	19	19	G2	PF7	I/O	FT_h	-	UART7_TX, OCTOSPI1_IO2, EVENTOUT	-
-	-	-	-	-	-	-	20	20	G4	PF8	I/O	FT_h	-	UART7_RTS/UART7_DE, OCTOSPI1_IO0, ETH_MII_TX_ER, PLAY1_OUT1, EVENTOUT	-
-	-	-	-	-	-	-	21	21	G3	PF9	I/O	FT_h	-	UART7_CTS, OCTOSPI1_IO1, ETH_MDC, FMC_SDNWE, EVENTOUT	-
-	-	-	-	-	-	-	22	22	H3	PF10	I/O	FT_h	-	OCTOSPI1_CLK, EVENTOUT	-
5	5	E14	5	12	12	F1	23	23	H1	PH0-OSC_IN(PH0)	I/O	FT	-	EVENTOUT	OSC_IN
6	6	F13	6	13	13	F2	24	24	H2	PH1-OSC_OUT(PH1)	I/O	FT	-	EVENTOUT	OSC_OUT
7	7	E12	7	14	14	G2	25	25	J1	NRST	I/O	RST	-	-	-
-	-	E10	8	15	15	G1	26	26	J2	PC0	I/O	FT_a	-	SPI4_MISO, SPI2_RDY, FMC_A25, OCTOSPI1_IO7, FMC_SDNWE, PLAY1_IN0, EVENTOUT	ADC12_INP10
-	-	E8	9	16	16	H3	27	27	K2	PC1	I/O	FT_ah	-	TRACED0, SPI2_MOSI/I2S2_SDO, SPI4_MOSI, OCTOSPI1_IO4, ETH_MDC, COMP2_OUT, EVENTOUT	ADC12_INP11, ADC12_INN10, TAMP_IN3/TAMP_OUT5, WKUP6
-	-	F11	10	17	17	H1	28	28	K1	PC2	I/O	FT_a	-	PWR_CSLEEP, TIM4_CH4, SPI2_MISO/I2S2_SDI, OCTOSPI1_IO5, OCTOSPI1_IO2, ETH_MII_TXD2, FMC_SDNE0, PLAY1_OUT3, EVENTOUT	ADC12_INP12, ADC12_INN11
-	-	F9	11	18	18	H2	29	29	L1	PC3	I/O	FT_a	-	PWR_CSTOP, LPUART1_TX, SPI2_MOSI/I2S2_SDO, OCTOSPI1_IO6, OCTOSPI1_IO0, ETH_MII_TX_CLK, FMC_SDCKE0, PLAY1_IN13, EVENTOUT	ADC12_INP13, ADC12_INN12



Table 11. STM32H543xx pin/ball definition (continued)

Pin Number										Pin name (function after reset)	Pin type	I/O structure	Notes	Alternate functions	Additional functions
LQFP48	UFQFPN48	WLCSP63	LQFP64	LQFP100-EP	LQFP100	UFBGA100	LQFP144-EP	LQFP144	UFBGA144						
-	-	H1	-	-	-	J3	30	30	F6	VDD	S	-	-	-	-
-	-	-	-	-	-	L7	-	-	D10	VSS	S	-	-	-	-
8	8	G12	12	19	19	J2	31	31	K3	VSSA	S	-	-	-	-
-	-	-	-	20	20	-	-	-	H4	VREF-	S	-	-	-	-
-	-	G14	-	21	21	J1	32	32	J3	VREF+	S	-	-	-	-
9	9	H13	13	22	22	K1	33	33	J4	VDDA	S	-	-	-	-
10	10	G10	14	23	23	L3	34	34	L2	PA0	I/O	FT_at	-	TIM2_CH1, TIM5_CH1, TIM8_ETR, TIM15_BKIN, SPI4_SCK, SPI3_RDY, USART2_CTS/USART2_NSS, UART4_TX, FDCAN2_RX, ETH_MII_CRX/ETH_B10T1S_ED_IN, ETH_10BT1S_ED, TIM2_ETR, EVENTOUT	ADC12_INP0, ADC12_INN1, COMP1_INM, TAMP_IN2/TAMP_OUT1, WKUP1
11	11	H11	15	24	24	K2	35	35	L3	PA1	I/O	FT_ah	-	TIM2_CH2, TIM5_CH2, TIM15_CH1N, LPTIM1_IN1, OCTOSPI1_DQS, USART2_RTS/USART2_DE, UART4_RX, OCTOSPI1_IO3, ETH_MII_RX_CLK/ETH_RMII_REF_CLK, USART6_CK, EVENTOUT	ADC12_INP1, TAMP_IN5/TAMP_OUT4
12	12	E6	16	25	25	K4	36	36	K4	PA2	I/O	FT_at	-	TIM2_CH3, TIM5_CH3, LPUART1_TX, TIM15_CH1, LPTIM1_IN2, USART2_TX, OCTOSPI1_NCS1, ETH_MDIO, EVENTOUT	ADC12_INP14, COMP2_INM, TAMP_IN4/TAMP_OUT3, WKUP2
13	13	F7	17	26	26	L1	37	37	M2	PA3	I/O	FT_ah	-	TIM2_CH4, TIM5_CH4, OCTOSPI1_CLK, TIM15_CH2, SPI2_NSS/I2S2_WS, SPI3_MOSI/I2S3_SDO, USART2_RX, ETH_MII_COL, PLAY1_IN6, EVENTOUT	ADC12_INP15, COMP2_INM
-	-	-	18	27	27	-	38	38	F5	VSS	S	-	-	-	-
-	-	J14	19	28	28	J10	39	39	F8	VDD	S	-	-	-	-
14	14	F5	20	29	29	L2	40	40	M3	PA4	I/O	TT_a	-	TIM5_ETR, LPTIM2_CH1, SPI3_MOSI/I2S3_SDO, SPI1_NSS/I2S1_WS, SPI3_NSS/I2S3_WS, USART2_CK, PLAY1_OUT12, EVENTOUT	ADC12_INP18, COMP1_INP, DAC1_OUT1
15	15	G8	21	30	30	M2	41	41	L4	PA5	I/O	TT_ah	-	TIM2_CH1, TIM8_CH1N, SPI1_SCK/I2S1_CK, ETH_MII_TX_EN/ETH_RMII_TX_EN, ETH_10BT1S_TX, TIM2_ETR, EVENTOUT	ADC12_INP19, ADC12_INN18, DAC1_OUT2



Table 11. STM32H543xx pin/ball definition (continued)

Pin Number										Pin name (function after reset)	Pin type	I/O structure	Notes	Alternate functions	Additional functions
LQFP48	UFQFPN48	WLCSP63	LQFP64	LQFP100-EP	LQFP100	UFBGA100	LQFP144-EP	LQFP144	UFBGA144						
16	16	G6	22	31	31	M1	42	42	M4	PA6	I/O	FT_ah	-	TIM1_BKIN, TIM3_CH1, TIM8_BKIN, SPI1_MISO/I2S1_SDI, OCTOSPI1_IO3, COMP1_OUT, EVENTOUT	ADC12_INP3, COMP2_INM
17	17	H7	23	32	32	L4	43	43	J5	PA7	I/O	FT_ah	-	TIM1_CH1N, TIM3_CH2, TIM8_CH1N, SPI1_MOSI/I2S1_SDO, OCTOSPI1_IO2, ETH_MII_RX_DV/ETH_RMII_CRS_DV, FMC_SDNWE, FMC_NWE, EVENTOUT	ADC12_INP7, ADC12_INN3, COMP1_INP
-	-	J10	24	33	33	M3	44	44	K5	PC4	I/O	FT_a	-	TIM2_CH4, LPTIM2_ETR, I2S1_MCK, USART3_RX, OCTOSPI1_NCS1, ETH_10BT1S_RX, ETH_MII_RXD0/ETH_B10T1S_RX_IN/ETH_RMII_RXD0, FMC_SDNE0, PLAY1_OUT4, EVENTOUT	ADC12_INP4
-	-	H9	25	34	34	M4	45	45	L5	PC5	I/O	FT_ah	-	TIM1_CH4N, SPI4_SCK, OCTOSPI1_DQS, ETH_MII_RXD1/ETH_RMII_RXD1, FMC_SDCKE0, COMP1_OUT, EVENTOUT	ADC12_INP8, ADC12_INN4
-	-	-	-	-	-	L6	-	-	G5	VDD	S	-	-	-	-
-	-	-	-	-	-	-	-	-	F7	VSS	S	-	-	-	-
18	18	H5	26	35	35	M5	46	46	M5	PB0	I/O	FT_ah	-	TIM1_CH2N, TIM3_CH3, TIM8_CH2N, SPI3_MISO/I2S3_SDI, OCTOSPI1_IO1, USART2_TX, UART4_CTS, ETH_MII_RXD2, COMP1_OUT, EVENTOUT	ADC12_INP9, ADC12_INN5, COMP2_INP
19	19	J8	27	36	36	K5	47	47	J6	PB1	I/O	FT_ah	-	TIM1_CH3N, TIM3_CH4, TIM8_CH3N, SPI3_SCK, SPI2_NSS/I2S2_WS, OCTOSPI1_IO0, USART3_RX, ETH_MII_RXD3, PLAY1_OUT5, EVENTOUT	ADC12_INP5, COMP1_INM
20	20	J6	28	37	37	L5	48	48	K6	PB2	I/O	FT_ah	-	RTC_OUT2, TIM8_CH4N, SPI1_RDY, LPTIM1_CH1, SPI2_SCK/I2S2_CK, SPI3_MOSI/I2S3_SDO, ETH_10BT1S_RX, OCTOSPI1_CLK, OCTOSPI1_DQS, ETH_MII_RXD0/ETH_B10T1S_RX_IN/ETH_RMII_RXD0, SDMMC1_CMD, PLAY1_IN8, EVENTOUT	ADC3_INP0, COMP2_INP, LSCO
-	-	-	-	-	-	-	49	49	L6	PF11	I/O	FT_ah	-	OCTOSPI1_NCLK, FMC_NRAS, PLAY1_IN2, EVENTOUT	ADC1_INP2
-	-	-	-	-	-	-	50	50	M6	PF12	I/O	FT_ah	-	FMC_A6, EVENTOUT	ADC1_INP6, ADC1_INN2
-	-	-	-	-	-	-	51	51	G6	VSS	S	-	-	-	-
-	-	-	-	-	-	-	52	52	G7	VDD	S	-	-	-	-



Table 11. STM32H543xx pin/ball definition (continued)

Pin Number										Pin name (function after reset)	Pin type	I/O structure	Notes	Alternate functions	Additional functions
LQFP48	UFQFPN48	WLCSP63	LQFP64	LQFP100-EP	LQFP100	UFBGA100	LQFP144-EP	LQFP144	UFBGA144						
-	-	-	-	-	-	-	53	53	M7	PF13	I/O	FT_ah	-	FMC_A7, PLAY1_IN11, EVENTOUT	ADC2_INP2
-	-	-	-	-	-	-	54	54	L7	PF14	I/O	FT_fah	-	FMC_A8, EVENTOUT	ADC2_INP6, ADC2_INN2
-	-	-	-	-	-	-	55	55	K7	PF15	I/O	FT_fh	-	I3C1_SDA, ETH_CLK, FMC_A9, EVENTOUT	-
-	-	-	-	-	-	-	56	56	M8	PG0	I/O	FT_h	-	FMC_A10, EVENTOUT	-
-	-	-	-	-	-	-	-	-	H5	VSS	S	-	-	-	-
-	-	-	-	-	-	-	-	-	H6	VDD	S	-	-	-	-
-	-	-	-	-	-	-	57	57	J7	PG1	I/O	FT_h	-	SPI2_MOSI/I2S2_SDO, FMC_A11, EVENTOUT	-
-	-	-	-	38	38	M6	58	58	L8	PE7	I/O	FT_ah	-	TIM1_ETR, UART7_RX, OCTOSPI1_IO4, FMC_D4/FMC_AD4, PLAY1_IN2, EVENTOUT	ADC3_INP1
-	-	-	-	39	39	M7	59	59	M9	PE8	I/O	FT_h	-	TIM1_CH1N, UART7_TX, OCTOSPI1_IO5, FMC_D5/FMC_AD5, PLAY1_OUT7, EVENTOUT	-
-	-	-	-	40	40	M8	60	60	K8	PE9	I/O	FT_h	-	TIM1_CH1, UART7_RTS/UART7_DE, OCTOSPI1_IO6, FMC_D6/FMC_AD6, PLAY1_IN12, EVENTOUT	-
-	-	-	-	-	-	-	61	61	H7	VSS	S	-	-	-	-
-	-	-	-	-	-	-	62	62	-	VDD	S	-	-	-	-
-	-	-	-	41	41	L8	63	63	L9	PE10	I/O	FT_ah	-	TIM1_CH2N, UART7_CTS, OCTOSPI1_IO7, FMC_D7/FMC_AD7, PLAY1_OUT8, EVENTOUT	ADC3_INP4
-	-	-	-	42	42	M9	64	64	M10	PE11	I/O	FT_ah	-	TIM1_CH2, SPI1_RDY, SPI4_NSS, OCTOSPI1_NCS1, FMC_D8/FMC_AD8, PLAY1_IN15, EVENTOUT	ADC3_INP5
-	-	-	-	43	43	K8	65	65	K9	PE12	I/O	FT_h	-	TIM1_CH3N, SPI4_SCK, ETH_MDIO, FMC_D9/FMC_AD9, PLAY1_OUT10, EVENTOUT	ADC3_INP6
-	-	-	-	44	44	L9	66	66	M11	PE13	I/O	FT_h	-	TIM1_CH3, SPI4_MISO, FMC_D10/FMC_AD10, PLAY1_OUT11, EVENTOUT	ADC3_INP7
-	-	-	-	45	45	M10	67	67	L10	PE14	I/O	FT_h	-	TIM1_CH4, SPI4_MOSI, FMC_D11/FMC_AD11, PLAY1_OUT6, EVENTOUT	ADC3_INP8
-	-	-	-	46	46	L10	68	68	K10	PE15	I/O	FT_h	-	TIM1_BKIN, TIM1_CH4N, FMC_D12/FMC_AD12, PLAY1_OUT9, EVENTOUT	ADC3_INP9



Table 11. STM32H543xx pin/ball definition (continued)

Pin Number										Pin name (function after reset)	Pin type	I/O structure	Notes	Alternate functions	Additional functions
LQFP48	UFQFPN48	WLCSP63	LQFP64	LQFP100-EP	LQFP100	UFBGA100	LQFP144-EP	LQFP144	UFBGA144						
21	21	G4	29	47	47	M11	69	69	L11	PB10	I/O	FT_f	-	TIM2_CH3, TIM8_CH1, LPTIM2_IN1, SPI2_SCK/I2S2_CK, USART3_TX, I3C2_SCL, OCTOSPI1_NCS2, ETH_MII_RX_ER, EVENTOUT	-
22	22	J4	30	48	48	K9	70	70	J8	VCAP	S	-	-	-	-
23	23	-	31	49	49	-	71	71	J9	VSS	S	-	-	-	-
24	24	-	32	50	50	-	72	72	-	VDD	S	-	-	-	-
25	25	H3	33	51	51	L11	73	73	L12	PB12	I/O	FT_h	-	TIM1_BKIN, TIM8_CH3, OCTOSPI1_NCLK, SPI2_NSS/I2S2_WS, UCPD1_FRSTX, USART3_CK, FDCAN2_RX, ETH_MII_TXD0/ETH_RMII_TXD0, UART5_RX, EVENTOUT	ADC3_INP3
26	26	G2	34	52	52	M12	74	74	K11	PB13	I/O	FT_c	-	TIM1_CH1N, TIM8_CH2, LPTIM2_CH1, I2C2_SMBA, SPI2_SCK/I2S2_CK, USART3_CTS/USART3_NSS, LPUART1_RX, FDCAN2_TX, SDMMC1_D0, UART5_TX, EVENTOUT	UCPD1_CC1
27	27	F3	35	53	53	K11	75	75	H8	PB14	I/O	FT_c	-	TIM1_CH2N, TIM12_CH1, TIM8_CH2N, USART1_TX, SPI2_MISO/I2S2_SDI, USART3_RTS/USART3_DE, UART4_RTS/UART4_DE, PLAY1_OUT2, EVENTOUT	UCPD1_CC2
28	28	F1	36	54	54	L12	76	76	H9	PB15	I/O	FT_h	-	RTC_REFIN, TIM1_CH3N, TIM12_CH2, TIM8_CH3N, USART1_RX, SPI2_MOSI/I2S2_SDO, SPI1_MOSI/I2S1_SDO, UART4_CTS, OCTOSPI1_CLK, ETH_MII_TXD1/ETH_RMII_TXD1, UART5_RX, EVENTOUT	ADC3_INP2, PVD_IN
-	-	-	-	55	55	K12	77	77	J10	PD8	I/O	FT_h	-	USART3_TX, ETH_MII_RXD0/ETH_B10T1S_RX_IN/ETH_RMII_RXD0, ETH_10BT1S_RX, FMC_D13/FMC_AD13, EVENTOUT	-
-	-	-	-	56	56	J11	78	78	J11	PD9	I/O	FT_h	-	USART3_RX, FDCAN2_RX, ETH_10BT1S_TX, FMC_D14/FMC_AD14, PLAY1_IN3, EVENTOUT	-
-	-	-	-	57	57	J12	79	79	K12	PD10	I/O	FT_h	-	LPTIM2_CH2, USART3_CK, ETH_MII_CRSD/ETH_B10T1S_ED_IN, ETH_10BT1S_ED, FMC_D15/FMC_AD15, EVENTOUT	-



Table 11. STM32H543xx pin/ball definition (continued)

Pin Number										Pin name (function after reset)	Pin type	I/O structure	Notes	Alternate functions	Additional functions
LQFP48	UFQFPN48	WL CSP63	LQFP64	LQFP100-EP	LQFP100	UFBGA100	LQFP144-EP	LQFP144	UFBGA144						
-	-	-	-	58	58	H10	80	80	G8	PD11	I/O	FT_h	-	LPTIM2_IN2, USART3_CTS/USART3_NSS, UART4_RX, OCTOSPI1_IO0, ETH_PTP_AUX_TS, FMC_A16/FMC_CLE, PLAY1_OUT0, EVENTOUT	-
-	-	-	-	59	59	H11	81	81	H10	PD12	I/O	FT_fh	-	LPTIM1_IN1, TIM4_CH1, LPTIM2_IN1, I2C2_SCL, I3C1_SCL, USART3_RTS/USART3_DE, UART4_TX, OCTOSPI1_IO1, FMC_A17/FMC_ALE, PLAY1_OUT1, EVENTOUT	-
-	-	-	-	60	60	H12	82	82	J12	PD13	I/O	FT_fh	-	LPTIM1_CH1, TIM4_CH2, LPTIM2_CH1, I2C2_SDA, I3C1_SDA, OCTOSPI1_IO3, FMC_A18, PLAY1_OUT13, EVENTOUT	-
-	-	-	-	-	-	-	83	83	M1	VSS	S	-	-	-	-
-	-	-	-	-	-	-	84	84	-	VDD	S	-	-	-	-
-	-	-	-	61	61	G11	85	85	H11	PD14	I/O	FT_h	-	TIM4_CH3, UART8_CTS, FMC_D0/FMC_AD0, PLAY1_IN1, EVENTOUT	-
-	-	-	-	62	62	G12	86	86	G9	PD15	I/O	FT_h	-	TIM4_CH4, UART8_RTS/UART8_DE, FMC_D1/FMC_AD1, PLAY1_OUT14, EVENTOUT	-
-	-	-	-	-	-	-	87	87	H12	PG2	I/O	FT_h	-	TIM8_BKIN, FMC_A12, EVENTOUT	-
-	-	-	-	-	-	-	88	88	G10	PG3	I/O	FT_h	-	TIM8_BKIN2, ETH_MII_RX_ER, FMC_A13, PLAY1_IN8, EVENTOUT	-
-	-	-	-	-	-	-	89	89	G11	PG4	I/O	FT_h	-	TIM1_BKIN2, FMC_A14/FMC_BA0, EVENTOUT	-
-	-	-	-	-	-	-	90	90	G12	PG5	I/O	FT_h	-	TIM1_ETR, FMC_A15/FMC_BA1, PLAY1_IN5, EVENTOUT	-
-	-	-	-	-	-	-	91	91	F12	PG6	I/O	FT_h	-	I3C1_SDA, SPI1_RDY, OCTOSPI1_NCS1, UCPD1_FRSTX, FMC_NE3, EVENTOUT	-
-	-	-	-	-	-	-	92	92	F11	PG7	I/O	FT_h	-	I3C1_SCL, USART6_CK, ETH_10BT1S_TX, UCPD1_FRSTX, FMC_INT, EVENTOUT	-
-	-	-	-	-	-	-	93	93	F10	PG8	I/O	FT_h	-	TIM8_ETR, SPI3_MOSI/I2S3_SDO, USART6_RTS/USART6_DE, ETH_PPS_OUT, FMC_SDCLK, EVENTOUT	-
-	-	-	-	-	-	-	94	94	M12	VSS	S	-	-	-	-
-	-	-	-	-	-	-	95	95	-	VDD	S	-	-	-	-



Table 11. STM32H543xx pin/ball definition (continued)

Pin Number										Pin name (function after reset)	Pin type	I/O structure	Notes	Alternate functions	Additional functions
LQFP48	UFQFPN48	WLSP63	LQFP64	LQFP100-EP	LQFP100	UFBGA100	LQFP144-EP	LQFP144	UFBGA144						
-	-	NC	37	63	63	F12	96	96	F9	PC6	I/O	FT_h	-	TIM3_CH1, TIM8_CH1, I2S2_MCK, USART6_TX, SDMMC1_D0DIR, FMC_NWAIT, I3C2_SCL, OCTOSPI1_IO5, SDMMC1_D6, PLAY1_IN9, EVENTOUT	-
-	-	E4	38	64	64	F11	97	97	E12	PC7	I/O	FT_h	-	TRGIO, TIM3_CH2, TIM8_CH2, I2S3_MCK, USART6_RX, SDMMC1_D123DIR, FMC_NE1, I3C2_SDA, OCTOSPI1_IO6, SDMMC1_D7, EVENTOUT	-
-	-	D1	39	65	65	E12	98	98	E11	PC8	I/O	FT_h	-	TRACED1, TIM3_CH3, TIM8_CH3, USART6_CK, UART5_RTS/UART5_DE, FMC_NE2/FMC_NCE, FMC_INT, FMC_ALE, SDMMC1_D0, PLAY1_OUT5, EVENTOUT	-
-	-	D3	40	66	66	E11	99	99	E10	PC9	I/O	FT_fh	-	MCO2, TIM3_CH4, TIM8_CH4, I2C3_SDA, AUDIOCLK, UART5_CTS, OCTOSPI1_IO0, I3C2_SDA, FMC_CLE, SDMMC1_D1, PLAY1_IN3, EVENTOUT	UCPD1_DB2
29	29	D5	41	67	67	E10	100	100	D12	PA8	I/O	FT_fh	-	MCO1, TIM1_CH1, TIM8_BKIN2, I2C3_SCL, SPI1_RDY, SPI4_MOSI, USART1_CK, I3C2_SCL, USB_SOF, UART7_RX, FMC_NOE, EVENTOUT	-
30	30	D7	42	68	68	D12	101	101	D11	PA9	I/O	FT_h	-	TIM1_CH2, LPUART1_TX, I2C3_SMBA, SPI2_SCK/I2S2_CK, USART1_TX, OCTOSPI1_NCS1, ETH_MII_TX_ER, FMC_NWE, PLAY1_IN4, EVENTOUT	UCPD1_DB1
31	31	C4	43	69	69	D11	102	102	B12	PA10	I/O	FT_h	-	TIM1_CH3, LPUART1_RX, LPTIM2_IN2, UCPD1_FRSTX, USART1_RX, FDCAN2_TX, ETH_CLK, SDMMC1_D0, EVENTOUT	-
32	32	C2	44	70	70	C12	103	103	C12	PA11	I/O	FT_u	-	TIM1_CH4, LPUART1_CTS, SPI2_NSS/I2S2_WS, UART4_RX, USART1_CTS/USART1_NSS, FDCAN1_RX, EVENTOUT	USB_DM
33	33	B1	45	71	71	C11	104	104	C11	PA12	I/O	FT_u	-	TIM1_ETR, LPUART1_RTS/LPUART1_DE, SPI2_SCK/I2S2_CK, UART4_TX, USART1_RTS/USART1_DE, FDCAN1_TX, COMP2_OUT, EVENTOUT	USB_DP
34	34	C6	46	72	72	B12	105	105	E9	PA13(JTMS/SWDIO)	I/O	FT	-	JTMS/SWDIO, EVENTOUT	-
-	-	-	-	73	73	C10	106	106	C10	VDDUSB	S	-	-	-	-
35	35	-	47	74	74	-	107	107	-	VSS	S	-	-	-	-



Table 11. STM32H543xx pin/ball definition (continued)

Pin Number										Pin name (function after reset)	Pin type	I/O structure	Notes	Alternate functions	Additional functions
LQFP48	UFQFPN48	WLSP63	LQFP64	LQFP100-EP	LQFP100	UFBGA100	LQFP144-EP	LQFP144	UFBGA144						
36	36	-	48	75	75	-	108	108	-	VDD	S	-	-	-	-
37	37	B3	49	76	76	B11	109	109	B11	PA14(JTCK/SWCLK)	I/O	FT	-	JTCK/SWCLK, EVENTOUT	-
38	38	B5	50	77	77	A11	110	110	E8	PA15(JTDI)	I/O	FT	-	JTDI, TIM2_CH1, HDMI_CEC, SPI1_NSS/I2S1_WS, SPI3_NSS/I2S3_WS, USART1_TX, UART4_RTS/UART4_DE, OCTOSPI1_NCS2, ETH_PHY_INTN, UART7_TX, FMC_NBL1, TIM2_ETR, EVENTOUT	-
-	-	C8	51	78	78	A12	111	111	A11	PC10	I/O	FT_h	-	I3C2_SCL, SPI3_SCK/I2S3_CK, USART3_TX, UART4_TX, OCTOSPI1_IO1, ETH_MII_TXD0/ETH_RMII_TXD0, SDMMC1_D2, PLAY1_IN0, EVENTOUT	-
-	-	B7	52	79	79	A10	112	112	D9	PC11	I/O	FT_h	-	SPI3_MISO/I2S3_SDI, USART3_RX, UART4_RX, OCTOSPI1_NCS2, SDMMC1_D3, EVENTOUT	-
-	-	A6	53	80	80	B10	113	113	B10	PC12	I/O	FT_h	-	TRACED3, TIM15_CH1, LPTIM2_CH2, SPI3_MOSI/I2S3_SDO, USART3_CK, UART5_TX, ETH_PPS_OUT, SDMMC1_CK, EVENTOUT	-
-	-	-	-	81	81	B9	114	114	D8	PD0	I/O	FT_h	-	TIM8_CH4N, UART4_RX, FDCAN1_RX, FMC_D2/FMC_AD2, EVENTOUT	-
-	-	-	-	82	82	A9	115	115	C9	PD1	I/O	FT_h	-	UART4_TX, FDCAN1_TX, ETH_MII_RX_DV/ETH_RMII_CRS_DV, FMC_D3/FMC_AD3, EVENTOUT	-
-	-	NC	54	83	83	B8	116	116	A10	PD2	I/O	FT_h	-	TRACED2, TIM3_ETR, TIM15_BKIN, UART5_RX, SDMMC1_CMD, PLAY1_IN7, EVENTOUT	WKUP7
-	-	-	-	84	84	A8	117	117	B9	PD3	I/O	FT_h	-	SPI2_SCK/I2S2_CK, USART2_CTS/USART2_NSS, ETH_10BT1S_TX, FMC_CLK, PLAY1_IN10, EVENTOUT	WKUP8
-	-	-	-	85	85	A7	118	118	A9	PD4	I/O	FT_h	-	USART2_RTS/USART2_DE, OCTOSPI1_IO4, ETH_CLK, FMC_NOE, EVENTOUT	-
-	-	-	-	86	86	B7	119	119	C8	PD5	I/O	FT_h	-	TIM1_CH4N, SPI2_RDY, ETH_MII_CRS/ETH_B10T1S_ED_IN, USART2_TX, FDCAN1_TX, OCTOSPI1_IO5, ETH_10BT1S_ED, FMC_NWE, EVENTOUT	-
-	-	-	-	-	-	-	120	120	-	VSS	S	-	-	-	-
-	-	-	-	-	-	C8	121	121	C5	VDDIO2	S	-	-	-	-



Table 11. STM32H543xx pin/ball definition (continued)

Pin Number										Pin name (function after reset)	Pin type	I/O structure	Notes	Alternate functions	Additional functions
LQFP48	UFQFPN48	WLCSP63	LQFP64	LQFP100-EP	LQFP100	UFBGA100	LQFP144-EP	LQFP144	UFBGA144						
-	-	-	-	87	87	A6	122	122	B8	PD6	I/O	FT_sh	-	I3C2_SCL, I2C3_SCL, SPI3_MOSI/I2S3_SDO, USART2_RX, OCTOSPI1_IO6, SDMMC1_CK, FMC_NWAIT, EVENTOUT	-
-	-	-	-	88	88	B6	123	123	A8	PD7	I/O	FT_sh	-	I3C2_SDA, I2C3_SDA, SPI1_MOSI/I2S1_SDO, SPI3_MISO/I2S3_SDI, USART2_CK, OCTOSPI1_IO7, SDMMC1_CMD, FMC_NE1/FMC_NCE, EVENTOUT	-
-	-	-	-	-	-	-	124	124	D7	PG9	I/O	FT_sh	-	SPI1_MISO/I2S1_SDI, USART6_RX, OCTOSPI1_IO6, SDMMC1_D0, FMC_NE2/FMC_NCE, EVENTOUT	-
-	-	-	-	-	-	-	125	125	B7	PG10	I/O	FT_sh	-	SPI1_NSS/I2S1_WS, SDMMC1_D1, FMC_NE3, EVENTOUT	-
-	-	-	-	-	-	-	126	126	A7	PG11	I/O	FT_sh	-	LPTIM1_IN2, SPI1_SCK/I2S1_CK, SDMMC1_D2, ETH_MII_TX_EN/ETH_RMII_TX_EN, EVENTOUT	-
-	-	-	-	-	-	-	127	127	A6	PG12	I/O	FT_sh	-	LPTIM1_IN1, USART6_RTS/USART6_DE, SDMMC1_D3, ETH_MII_TXD1/ETH_RMII_TXD1, FMC_NE4, EVENTOUT	-
-	-	-	-	-	-	-	128	128	D6	PG13	I/O	FT_sh	-	TRACED0, LPTIM1_CH1, USART6_CTS/USART6_NSS, ETH_MII_TXD0/ETH_RMII_TXD0, FMC_A24, EVENTOUT	-
-	-	-	-	-	-	-	129	129	B6	PG14	I/O	FT_sh	-	TRACED1, LPTIM1_ETR, LPTIM1_CH2, USART6_TX, OCTOSPI1_IO7, ETH_MII_TXD1/ETH_RMII_TXD1, FMC_A25, EVENTOUT	-
-	-	-	-	-	-	-	130	130	-	VSS	S	-	-	-	-
-	-	-	-	-	-	-	131	131	-	VDD	S	-	-	-	-
-	-	-	-	-	-	-	132	132	A5	PG15	I/O	FT_h	-	SPI4_RDY, USART6_CTS/USART6_NSS, FMC_NCAS, EVENTOUT	-
39	39	A8	55	89	89	A5	133	133	B5	PB3(JTDO/TRACESWO)	I/O	FT_h	-	JTDO/TRACESWO, TIM2_CH2, I3C2_SDA, I2C2_SDA, SPI1_SCK/I2S1_CK, SPI3_SCK/I2S3_CK, LPUART1_TX, FDCAN2_TX, CRS_SYNC, UART7_RX, ETH_MDC, UART5_TX, EVENTOUT	-



Table 11. STM32H543xx pin/ball definition (continued)

Pin Number										Pin name (function after reset)	Pin type	I/O structure	Notes	Alternate functions	Additional functions
LQFP48	UFQFPN48	WLCSP63	LQFP64	LQFP100-EP	LQFP100	UFBGA100	LQFP144-EP	LQFP144	UFBGA144						
40	40	B9	56	90	90	B5	134	134	A4	PB4(NJTRST)	I/O	FT_h	-	NJTRST, TIM3_CH1, OCTOSPI1_CLK, LPTIM1_CH2, SPI1_MISO/I2S1_SDI, SPI3_MISO/I2S3_SDI, SPI2_NSS/I2S2_WS, I3C2_SDA, I2C3_SDA, ETH_MDIO, UART7_TX, EVENTOUT	-
41	41	A10	57	91	91	A4	135	135	E6	PB5	I/O	FT_h	-	TIM3_CH2, OCTOSPI1_NCLK, I2C1_SMBA, SPI1_MOSI/I2S1_SDO, USART6_TX, SPI3_MOSI/I2S3_SDO, FDCAN2_RX, ETH_PPS_OUT, FMC_SDCKE1, UART5_RX, EVENTOUT	-
42	42	D9	58	92	92	B4	136	136	B4	PB6	I/O	FT_f	-	TIM4_CH1, I3C1_SCL, I2C1_SCL, HDMI_CEC, USART6_RX, USART1_TX, LPUART1_TX, FDCAN2_TX, OCTOSPI1_NCS2, ETH_MII_TX_ER, FMC_SDNE1, UART5_TX, EVENTOUT	-
43	43	D11	59	93	93	C5	137	137	A3	PB7	I/O	FT_fa	-	TIM4_CH2, I3C1_SDA, I2C1_SDA, SPI4_MISO, USART6_CTS/USART6_NSS, USART1_RX, LPUART1_RX, FDCAN1_TX, FMC_NL, EVENTOUT	WKUP5
44	44	C10	60	94	94	A3	138	138	C4	BOOT0	I	B	-	-	-
45	45	E2	61	95	95	A2	139	139	B3	PB8	I/O	FT_fsh	-	TIM4_CH3, I3C1_SCL, I2C1_SCL, SPI4_RDY, SPI3_NSS/I2S3_WS, SDMMC1_CKIN, UART4_RX, FDCAN1_RX, ETH_MII_TXD3, SDMMC1_D4, PLAY1_IN1, EVENTOUT	-
-	-	-	-	96	96	A1	140	140	A2	PB9	I/O	FT_fsh	-	TIM4_CH4, I3C1_SDA, I2C1_SDA, SPI2_NSS/I2S2_WS, SPI3_SCK/I2S3_CK, SDMMC1_CDIR, UART4_TX, FDCAN1_TX, SDMMC1_D5, COMP2_OUT, EVENTOUT	-
-	-	-	-	97	97	B1	141	141	B2	PE0	I/O	FT_h	-	LPTIM1_ETR, TIM4_ETR, LPTIM2_CH2, LPTIM2_ETR, SPI3_RDY, UART8_RX, FDCAN1_RX, FMC_NBL0, EVENTOUT	-
46	46	A12	62	98	98	C4	142	142	D5	VCAP	S	-	-	-	-
47	47	-	63	99	99	-	143	143	-	VSS	S	-	-	-	-
48	48	-	64	100	100	-	144	144	-	VDD	S	-	-	-	-
-	-	-	-	-	-	-	-	-	C7	VDDIO2	S	-	-	-	-



4.3 Alternate functions

Table 12. Alternate functions AF0 to AF7

Port	AF0	AF1	AF2	AF3	AF4	AF5	AF6	AF7
	SYS	LPTIM1/TIM1/2	TIM3/4/5/8/12/15	I3C1/2/LPTIM2/LPUART1/OCTOSPI/TIM1/8	CEC/I2C1/2/3/LPTIM1/2/SPI1/I2S1/SPI3/I2S3/TIM15/USART1	CEC/LPTIM1/SPI1/I2S1/SPI2/I2S2/SPI3/I2S3/SPI4	ETH_/I3C1/OCTOSPI/SPI1/I2S1/SPI2/I2S2/SPI3/I2S3/SPI4/UART4/USART6/USB_PD	ETH_/SDMMC1/SPI2/I2S2/SPI3/I2S3/UART7/USART1/2/3/6
PA0	-	TIM2_CH1	TIM5_CH1	TIM8_ETR	TIM15_BKIN	SPI4_SCK	SPI3_RDY	USART2_CTS/USART2_NSS
PA1	-	TIM2_CH2	TIM5_CH2	-	TIM15_CH1N	LPTIM1_IN1	OCTOSPI1_DQS	USART2_RTS/USART2_DE
PA2	-	TIM2_CH3	TIM5_CH3	LPUART1_TX	TIM15_CH1	LPTIM1_IN2	-	USART2_TX
PA3	-	TIM2_CH4	TIM5_CH4	OCTOSPI1_CLK	TIM15_CH2	SPI2_NSS/I2S2_WS	SPI3_MOSI/I2S3_SDO	USART2_RX
PA4	-	-	TIM5_ETR	LPTIM2_CH1	SPI3_MOSI/I2S3_SDO	SPI1_NSS/I2S1_WS	SPI3_NSS/I2S3_WS	USART2_CK
PA5	-	TIM2_CH1	-	TIM8_CH1N	-	SPI1_SCK/I2S1_CK	-	-
PA6	-	TIM1_BKIN	TIM3_CH1	TIM8_BKIN	-	SPI1_MISO/I2S1_SDI	OCTOSPI1_IO3	-
PA7	-	TIM1_CH1N	TIM3_CH2	TIM8_CH1N	-	SPI1_MOSI/I2S1_SDO	-	-
PA8	MCO1	TIM1_CH1	-	TIM8_BKIN2	I2C3_SCL	SPI1_RDY	SPI4_MOSI	USART1_CK
PA9	-	TIM1_CH2	-	LPUART1_TX	I2C3_SMBA	SPI2_SCK/I2S2_CK	-	USART1_TX
PA10	-	TIM1_CH3	-	LPUART1_RX	LPTIM2_IN2	-	UCPD1_FRSTX	USART1_RX
PA11	-	TIM1_CH4	-	LPUART1_CTS	-	SPI2_NSS/I2S2_WS	UART4_RX	USART1_CTS/USART1_NSS
PA12	-	TIM1_ETR	-	LPUART1_RTS/LPUART1_DE	-	SPI2_SCK/I2S2_CK	UART4_TX	USART1_RTS/USART1_DE
PA13	JTMS/SWDIO	-	-	-	-	-	-	-
PA14	JTCK/SWCLK	-	-	-	-	-	-	-
PA15	JTDI	TIM2_CH1	-	-	HDMI_CEC	SPI1_NSS/I2S1_WS	SPI3_NSS/I2S3_WS	USART1_TX

A



Table 12. Alternate functions AF0 to AF7 (continued)

Port	AF0	AF1	AF2	AF3	AF4	AF5	AF6	AF7
	SYS	LPTIM1/TIM1/2	TIM3/4/5/8/12/15	I3C1/2/LPTIM2/LPUART1/OCTOSPI/TIM1/8	CEC/I2C1/2/3/LPTIM1/2/SPI1/I2S1/SPI3/I2S3/TIM15/USART1	CEC/LPTIM1/SPI1/I2S1/SPI2/I2S2/SPI3/I2S3/SPI4	ETH_/I3C1/OCTOSPI/SPI1/I2S1/SPI2/I2S2/SPI3/I2S3/SPI4/UART4/USART6/USB_PD	ETH_/SDMMC1/SPI2/I2S2/SPI3/I2S3/UART7/USART1/2/3/6
PB0	-	TIM1_CH2N	TIM3_CH3	TIM8_CH2N	-	SPI3_MISO/I2S3_SDI	OCTOSPI1_IO1	USART2_TX
PB1	-	TIM1_CH3N	TIM3_CH4	TIM8_CH3N	SPI3_SCK	SPI2_NSS/I2S2_WS	OCTOSPI1_IO0	USART3_RX
PB2	RTC_OUT2	-	-	TIM8_CH4N	SPI1_RDY	LPTIM1_CH1	SPI2_SCK/I2S2_CK	SPI3_MOSI/I2S3_SDO
PB3	JTDO/TRACESW0	TIM2_CH2	-	I3C2_SDA	I2C2_SDA	SPI1_SCK/I2S1_CK	SPI3_SCK/I2S3_CK	-
PB4	NJTRST	-	TIM3_CH1	OCTOSPI1_CLK	LPTIM1_CH2	SPI1_MISO/I2S1_SDI	SPI3_MISO/I2S3_SDI	SPI2_NSS/I2S2_WS
PB5	-	-	TIM3_CH2	OCTOSPI1_NCLK	I2C1_SMBA	SPI1_MOSI/I2S1_SDO	USART6_TX	SPI3_MOSI/I2S3_SDO
PB6	-	-	TIM4_CH1	I3C1_SCL	I2C1_SCL	HDMI_CEC	USART6_RX	USART1_TX
PB7	-	-	TIM4_CH2	I3C1_SDA	I2C1_SDA	SPI4_MISO	USART6_CTS/USART6_NSS	USART1_RX
PB8	-	-	TIM4_CH3	I3C1_SCL	I2C1_SCL	SPI4_RDY	SPI3_NSS/I2S3_WS	SDMMC1_CKIN
PB9	-	-	TIM4_CH4	I3C1_SDA	I2C1_SDA	SPI2_NSS/I2S2_WS	SPI3_SCK/I2S3_CK	SDMMC1_CDIR
PB10	-	TIM2_CH3	TIM8_CH1	LPTIM2_IN1	-	SPI2_SCK/I2S2_CK	-	USART3_TX
PB12	-	TIM1_BKIN	TIM8_CH3	OCTOSPI1_NCLK	-	SPI2_NSS/I2S2_WS	UCPD1_FRSTX	USART3_CK
PB13	-	TIM1_CH1N	TIM8_CH2	LPTIM2_CH1	I2C2_SMBA	SPI2_SCK/I2S2_CK	-	USART3_CTS/USART3_NSS
PB14	-	TIM1_CH2N	TIM12_CH1	TIM8_CH2N	USART1_TX	SPI2_MISO/I2S2_SDI	-	USART3_RTS/USART3_DE
PB15	RTC_REFIN	TIM1_CH3N	TIM12_CH2	TIM8_CH3N	USART1_RX	SPI2_MOSI/I2S2_SDO	SPI1_MOSI/I2S1_SDO	-



Table 12. Alternate functions AF0 to AF7 (continued)

Port	AF0	AF1	AF2	AF3	AF4	AF5	AF6	AF7
	SYS	LPTIM1/TIM1/ 2	TIM3/4/5/8/1 2/15	I3C1/2/LPTIM2/ LPUART1/ OCTOSPI/TIM1/8	CEC/I2C1/2/3/ LPTIM1/2/SPI1/I2 S1/SPI3/I2S3/TIM 15/USART1	CEC/LPTIM1/ SPI1/I2S1/SPI2 /I2S2/ SPI3/I2S3/SPI4	ETH_/I3C1/OCTOSPI/ SPI1/I2S1/SPI2/I2S2/ SPI3/I2S3/SPI4/UART4/ USART6/USB_PD	ETH_/SDMMC1/ SPI2/I2S2/ SPI3/I2S3/UART7/ USART1/2/3/6
PC0	-	-	-	-	-	-	SPI4_MISO	SPI2_RDY
PC1	TRACED0	-	-	-	-	SPI2_MOSI/I2S2 _SDO	SPI4_MOSI	-
PC2	PWR_CSLEEP	-	TIM4_CH4	-	-	SPI2_MISO/I2S2 _SDI	OCTOSPI1_IO5	-
PC3	PWR_CSTOP	-	-	LPUART1_TX	-	SPI2_MOSI/I2S2 _SDO	OCTOSPI1_IO6	-
PC4	-	TIM2_CH4	-	LPTIM2_ETR	-	I2S1_MCK	-	USART3_RX
PC5	-	TIM1_CH4N	-	-	-	-	SPI4_SCK	-
PC6	-	-	TIM3_CH1	TIM8_CH1	-	I2S2_MCK	-	USART6_TX
PC7	TRGIO	-	TIM3_CH2	TIM8_CH2	-	-	I2S3_MCK	USART6_RX
PC8	TRACED1	-	TIM3_CH3	TIM8_CH3	-	-	-	USART6_CK
PC9	MCO2	-	TIM3_CH4	TIM8_CH4	I2C3_SDA	AUDIOCLK	-	-
PC10	-	-	-	I3C2_SCL	-	-	SPI3_SCK/I2S3_CK	USART3_TX
PC11	-	-	-	-	-	-	SPI3_MISO/I2S3_SDI	USART3_RX
PC12	TRACED3	-	TIM15_CH1	LPTIM2_CH2	-	-	SPI3_MOSI/I2S3_SDO	USART3_CK
PC13	-	-	-	-	-	-	-	-
PC14	-	-	-	-	-	-	-	-
PC15	-	-	-	-	-	-	-	-



Table 12. Alternate functions AF0 to AF7 (continued)

Port	AF0	AF1	AF2	AF3	AF4	AF5	AF6	AF7
	SYS	LPTIM1/TIM1/ 2	TIM3/4/5/8/1 2/15	I3C1/2/LPTIM2/ LPUART1/ OCTOSPI/TIM1/8	CEC/I2C1/2/3/ LPTIM1/2/SPI1/I2 S1/SPI3/I2S3/TIM 15/USART1	CEC/LPTIM1/ SPI1/I2S1/SPI2 /I2S2/ SPI3/I2S3/SPI4	ETH_/I3C1/OCTOSPI/ SPI1/I2S1/SPI2/I2S2/ SPI3/I2S3/SPI4/UART4/ USART6/USB_PD	ETH_/SDMMC1/ SPI2/I2S2/ SPI3/I2S3/UART7/ USART1/2/3/6
PD0	-	-	-	TIM8_CH4N	-	-	-	-
PD1	-	-	-	-	-	-	-	-
PD2	TRACED2	-	TIM3_ETR	-	TIM15_BKIN	-	-	-
PD3	-	-	-	-	-	SPI2_SCK/I2S2_ CK	-	USART2_CTS/USAR T2_NSS
PD4	-	-	-	-	-	-	-	USART2_RTS/USAR T2_DE
PD5	-	TIM1_CH4N	-	-	-	SPI2_RDY	ETH_MII_CRX/ETH_B10T1 S_ED_IN	USART2_TX
PD6	-	-	-	I3C2_SCL	I2C3_SCL	SPI3_MOSI/I2S3 _SDO	-	USART2_RX
PD7	-	-	-	I3C2_SDA	I2C3_SDA	SPI1_MOSI/I2S1 _SDO	SPI3_MISO/I2S3_SDI	USART2_CK
PD8	-	-	-	-	-	-	-	USART3_TX
PD9	-	-	-	-	-	-	-	USART3_RX
PD10	-	-	-	LPTIM2_CH2	-	-	-	USART3_CK
PD11	-	-	-	LPTIM2_IN2	-	-	-	USART3_CTS/USAR T3_NSS
PD12	-	LPTIM1_IN1	TIM4_CH1	LPTIM2_IN1	I2C2_SCL	-	I3C1_SCL	USART3_RTS/USAR T3_DE
PD13	-	LPTIM1_CH1	TIM4_CH2	LPTIM2_CH1	I2C2_SDA	-	I3C1_SDA	-
PD14	-	-	TIM4_CH3	-	-	-	-	-
PD15	-	-	TIM4_CH4	-	-	-	-	-



Table 12. Alternate functions AF0 to AF7 (continued)

Port	AF0	AF1	AF2	AF3	AF4	AF5	AF6	AF7	
	SYS	LPTIM1/TIM1/ 2	TIM3/4/5/8/1 2/15	I3C1/2/LPTIM2/ LPUART1/ OCTOSPI/TIM1/8	CEC/I2C1/2/3/ LPTIM1/2/SPI1/I2 S1/SPI3/I2S3/TIM 15/USART1	CEC/LPTIM1/ SPI1/I2S1/SPI2 /I2S2/ SPI3/I2S3/SPI4	ETH_/I3C1/OCTOSPI/ SPI1/I2S1/SPI2/I2S2/ SPI3/I2S3/SPI4/UART4/ USART6/USB_PD	ETH_/SDMMC1/ SPI2/I2S2/ SPI3/I2S3/UART7/ USART1/2/3/6	
E	PE0	-	LPTIM1_ETR	TIM4_ETR	LPTIM2_CH2	LPTIM2_ETR	-	SPI3_RDY	-
	PE2	TRACECLK	LPTIM1_IN2	-	-	-	SPI4_SCK	-	-
	PE3	TRACED0	-	-	-	TIM15_BKIN	-	-	-
	PE4	TRACED1	-	-	-	TIM15_CH1N	SPI4_NSS	-	ETH_10BT1S_RX
	PE5	TRACED2	-	-	-	TIM15_CH1	SPI4_MISO	-	-
	PE6	TRACED3	TIM1_BKIN2	-	-	TIM15_CH2	SPI4_MOSI	-	-
	PE7	-	TIM1_ETR	-	-	-	-	-	UART7_RX
	PE8	-	TIM1_CH1N	-	-	-	-	-	UART7_TX
	PE9	-	TIM1_CH1	-	-	-	-	-	UART7_RTS/UART7_DE
	PE10	-	TIM1_CH2N	-	-	-	-	-	UART7_CTS
	PE11	-	TIM1_CH2	-	-	SPI1_RDY	SPI4_NSS	OCTOSPI1_NCS1	-
	PE12	-	TIM1_CH3N	-	-	-	SPI4_SCK	-	-
	PE13	-	TIM1_CH3	-	-	-	SPI4_MISO	-	-
	PE14	-	TIM1_CH4	-	-	-	SPI4_MOSI	-	-
	PE15	-	TIM1_BKIN	-	TIM1_CH4N	-	-	-	-



Table 12. Alternate functions AF0 to AF7 (continued)

Port	AF0	AF1	AF2	AF3	AF4	AF5	AF6	AF7
	SYS	LPTIM1/TIM1/ 2	TIM3/4/5/8/1 2/15	I3C1/2/LPTIM2/ LPUART1/ OCTOSPI/TIM1/8	CEC/I2C1/2/3/ LPTIM1/2/SPI1/I2 S1/SPI3/I2S3/TIM 15/USART1	CEC/LPTIM1/ SPI1/I2S1/SPI2 /I2S2/ SPI3/I2S3/SPI4	ETH_/I3C1/OCTOSPI/ SPI1/I2S1/SPI2/I2S2/ SPI3/I2S3/SPI4/UART4/ USART6/USB_PD	ETH_/SDMMC1/ SPI2/I2S2/ SPI3/I2S3/UART7/ USART1/2/3/6
F	PF0	-	-	-	I3C2_SDA	I2C2_SDA	-	-
	PF1	-	-	-	I3C2_SCL	I2C2_SCL	-	-
	PF2	-	-	-	-	I2C2_SMBA	-	-
	PF3	-	-	-	-	-	-	-
	PF4	-	-	-	-	-	-	-
	PF5	-	-	-	-	-	I3C1_SCL	-
	PF6	-	-	-	-	-	-	UART7_RX
	PF7	-	-	-	-	-	-	UART7_TX
	PF8	-	-	-	-	-	-	UART7_RTS/UART7_DE
	PF9	-	-	-	-	-	-	UART7_CTS
	PF10	-	-	-	-	-	-	-
	PF11	-	-	-	-	-	-	-
	PF12	-	-	-	-	-	-	-
	PF13	-	-	-	-	-	-	-
	PF14	-	-	-	-	-	-	-
PF15	-	-	-	-	-	-	I3C1_SDA	



Table 12. Alternate functions AF0 to AF7 (continued)

Port	AF0	AF1	AF2	AF3	AF4	AF5	AF6	AF7
	SYS	LPTIM1/TIM1/ 2	TIM3/4/5/8/1 2/15	I3C1/2/LPTIM2/ LPUART1/ OCTOSPI/TIM1/8	CEC/I2C1/2/3/ LPTIM1/2/SPI1/I2 S1/SPI3/I2S3/TIM 15/USART1	CEC/LPTIM1/ SPI1/I2S1/SPI2 /I2S2/ SPI3/I2S3/SPI4	ETH_/I3C1/OCTOSPI/ SPI1/I2S1/SPI2/I2S2/ SPI3/I2S3/SPI4/UART4/ USART6/USB_PD	ETH_/SDMMC1/ SPI2/I2S2/ SPI3/I2S3/UART7/ USART1/2/3/6
G	PG0	-	-	-	-	-	-	-
	PG1	-	-	-	-	-	-	SPI2_MOSI/I2S2_SD O
	PG2	-	-	-	TIM8_BKIN	-	-	-
	PG3	-	-	-	TIM8_BKIN2	-	-	-
	PG4	-	TIM1_BKIN2	-	-	-	-	-
	PG5	-	TIM1_ETR	-	-	-	-	-
	PG6	-	-	-	I3C1_SDA	-	SPI1_RDY	-
	PG7	-	-	-	I3C1_SCL	-	-	USART6_CK
	PG8	-	-	-	TIM8_ETR	-	SPI3_MOSI/I2S3 _SDO	USART6_RTS/USAR T6_DE
	PG9	-	-	-	-	-	SPI1_MISO/I2S1 _SDI	USART6_RX
	PG10	-	-	-	-	-	SPI1_NSS/I2S1_ WS	-
	PG11	-	LPTIM1_IN2	-	-	-	SPI1_SCK/I2S1_ CK	-
	PG12	-	LPTIM1_IN1	-	-	-	-	USART6_RTS/USAR T6_DE
	PG13	TRACED0	LPTIM1_CH1	-	-	-	-	USART6_CTS/USAR T6_NSS
	PG14	TRACED1	LPTIM1_ETR	-	-	LPTIM1_CH2	-	USART6_TX
PG15	-	-	-	-	-	SPI4_RDY	USART6_CTS/USAR T6_NSS	
H	PH0	-	-	-	-	-	-	-
	PH1	-	-	-	-	-	-	-



Table 13. Alternate functions AF8 to AF15

Port	AF8	AF9	AF10	AF11	AF12	AF13	AF14	AF15	
	ETH_/I3C2/LPUART1/SDMMC1/UART4/5/8	FDCAN1/2/FMC[NAND16]/FMC[NORmux]/FMC[NOR_RAM]/I2C3/I3C2/OCTOSPI	CRS/ETH_/FMC[NAND16]/I3C2/OCTOSPI/SDMMC1/USB_	ETH_/FMC[NAND16]/OCTOSPI/SDMMC1/UART7/USB_PD	ETH_/FMC[NAND16]/FMC[NORmux]/FMC[NOR_RAM]/FMC[SDRAM_16bit]/SDMMC1	COMP1/FMC[NAND16]/FMC[NORmux]/FMC[NOR_RAM]/UART8	COMP2/PLAY1_IN/PLAY1_OUT/TIM2/UART5/USART6	SYS	
A	PA0	UART4_TX	FDCAN2_RX	-	ETH_MII_CRS/ETH_B10T1S_ED_IN	ETH_10BT1S_ED	-	TIM2_ETR	EVENTOUT
	PA1	UART4_RX	OCTOSPI1_IO3	-	ETH_MII_RX_CLK/ETH_RMII_REF_CLK	-	-	USART6_CK	EVENTOUT
	PA2	-	-	OCTOSPI1_NCS1	ETH_MDIO	-	-	-	EVENTOUT
	PA3	-	-	-	ETH_MII_COL	-	-	PLAY1_IN6	EVENTOUT
	PA4	-	-	-	-	-	-	PLAY1_OUT12	EVENTOUT
	PA5	-	-	-	ETH_MII_TX_EN/ETH_RMII_TX_EN	ETH_10BT1S_TX	-	TIM2_ETR	EVENTOUT
	PA6	-	-	-	-	-	COMP1_OUT	-	EVENTOUT
	PA7	-	-	OCTOSPI1_IO2	ETH_MII_RX_DV/ETH_RMII_CRS_DV	FMC_SDNWE	FMC_NWE	-	EVENTOUT
	PA8	-	I3C2_SCL	USB_SOF	UART7_RX	FMC_NOE	-	-	EVENTOUT
	PA9	-	-	OCTOSPI1_NCS1	ETH_MII_TX_ER	FMC_NWE	-	PLAY1_IN4	EVENTOUT
	PA10	-	FDCAN2_TX	-	ETH_CLK	SDMMC1_D0	-	-	EVENTOUT
	PA11	-	FDCAN1_RX	-	-	-	-	-	EVENTOUT
	PA12	-	FDCAN1_TX	-	-	-	-	COMP2_OUT	EVENTOUT
	PA13	-	-	-	-	-	-	-	EVENTOUT
	PA14	-	-	-	-	-	-	-	EVENTOUT
PA15	UART4_RTS/UART4_DE	OCTOSPI1_NCS2	ETH_PHY_INTN	UART7_TX	FMC_NBL1	-	TIM2_ETR	EVENTOUT	



Table 13. Alternate functions AF8 to AF15

Port	AF8	AF9	AF10	AF11	AF12	AF13	AF14	AF15	
	ETH_I3C2/LPUART1/SDMMC1/UART4/5/8	FDCAN1/2/FMC[NAND16]/FMC[NORmux]/FMC[NOR_RAM]/I2C3/I3C2/OCTOSPI	CRS/ETH_/FMC[NAND16]/I3C2/OCTOSPI/SDMMC1/USB_	ETH_/FMC[NAND16]/OCTOSPI/SDMMC1/UART7/USB_PD	ETH_/FMC[NAND16]/FMC[NORmux]/FMC[NOR_RAM]/FMC[SDRAM_16bit]/SDMMC1	COMP1/FMC[NAND16]/FMC[NORmux]/FMC[NOR_RAM]/UART8	COMP2/PLAY1_IN/PLAY1_OUT/TIM2/UART5/USART6	SYS	
B	PB0	UART4_CTS	-	-	ETH_MII_RXD2	-	COMP1_OUT	-	EVENTOUT
	PB1	-	-	-	ETH_MII_RXD3	-	-	PLAY1_OUT5	EVENTOUT
	PB2	ETH_10BT1S_RX	OCTOSPI1_CLK	OCTOSPI1_DQS	ETH_MII_RXD0/ETH_B10T1S_RX_IN/ETH_RMII_RXD0	SDMMC1_CMD	-	PLAY1_IN8	EVENTOUT
	PB3	LPUART1_TX	FDCAN2_TX	CRS_SYNC	UART7_RX	ETH_MDC	-	UART5_TX	EVENTOUT
	PB4	I3C2_SDA	I2C3_SDA	ETH_MDIO	UART7_TX	-	-	-	EVENTOUT
	PB5	-	FDCAN2_RX	-	ETH_PPS_OUT	FMC_SDCKE1	-	UART5_RX	EVENTOUT
	PB6	LPUART1_TX	FDCAN2_TX	OCTOSPI1_NCS2	ETH_MII_TX_ER	FMC_SDNE1	-	UART5_TX	EVENTOUT
	PB7	LPUART1_RX	FDCAN1_TX	-	-	FMC_NL	-	-	EVENTOUT
	PB8	UART4_RX	FDCAN1_RX	-	ETH_MII_TXD3	SDMMC1_D4	-	PLAY1_IN1	EVENTOUT
	PB9	UART4_TX	FDCAN1_TX	-	-	SDMMC1_D5	-	COMP2_OUT	EVENTOUT
	PB10	I3C2_SCL	OCTOSPI1_NCS2	-	ETH_MII_RX_ER	-	-	-	EVENTOUT
	PB12	-	FDCAN2_RX	-	ETH_MII_TXD0/ETH_RMII_TXD0	-	-	UART5_RX	EVENTOUT
	PB13	LPUART1_RX	FDCAN2_TX	-	-	SDMMC1_D0	-	UART5_TX	EVENTOUT
	PB14	UART4_RTS/UART4_DE	-	-	-	-	-	PLAY1_OUT2	EVENTOUT
	PB15	UART4_CTS	-	OCTOSPI1_CLK	ETH_MII_TXD1/ETH_RMII_TXD1	-	-	UART5_RX	EVENTOUT



Table 13. Alternate functions AF8 to AF15

Port	AF8	AF9	AF10	AF11	AF12	AF13	AF14	AF15	
	ETH_/I3C2/LPUART1/SDMMC1/UART4/5/8	FDCAN1/2/FMC[NAND16]/FMC[NORmux]/FMC[NOR_RAM]/I2C3/I3C2/OCTOSPI	CRS/ETH_/FMC[NAND16]/I3C2/OCTOSPI/SDMMC1/USB_	ETH_/FMC[NAND16]/OCTOSPI/SDMMC1/UART7/USB_PD	ETH_/FMC[NAND16]/FMC[NORmux]/FMC[NOR_RAM]/FMC[SDRAM_16bit]/SDMMC1	COMP1/FMC[NAND16]/FMC[NORmux]/FMC[NOR_RAM]/UART8	COMP2/PLAY1_IN/PLAY1_OUT/TIM2/UART5/USART6	SYS	
C	PC0	-	FMC_A25	OCTOSPI1_IO7	-	FMC_SDNWE	-	PLAY1_IN0	EVENTOUT
	PC1	-	-	OCTOSPI1_IO4	ETH_MDC	-	-	COMP2_OUT	EVENTOUT
	PC2	-	OCTOSPI1_IO2	-	ETH_MII_TXD2	FMC_SDNE0	-	PLAY1_OUT3	EVENTOUT
	PC3	-	OCTOSPI1_IO0	-	ETH_MII_TX_CLK	FMC_SDCKE0	-	PLAY1_IN13	EVENTOUT
	PC4	-	OCTOSPI1_NCS1	ETH_10BT1S_RX	ETH_MII_RXD0/ETH_B10T1S_RX_IN/ETH_RMII_RXD0	FMC_SDNE0	-	PLAY1_OUT4	EVENTOUT
	PC5	-	-	OCTOSPI1_DQS	ETH_MII_RXD1/ETH_RMII_RXD1	FMC_SDCKE0	COMP1_OUT	-	EVENTOUT
	PC6	SDMMC1_D0DIR	FMC_NWAIT	I3C2_SCL	OCTOSPI1_IO5	SDMMC1_D6	-	PLAY1_IN9	EVENTOUT
	PC7	SDMMC1_D123DIR	FMC_NE1	I3C2_SDA	OCTOSPI1_IO6	SDMMC1_D7	-	-	EVENTOUT
	PC8	UART5_RTS/UART5_DE	FMC_NE2/FMC_NCE	FMC_INT	FMC_ALE	SDMMC1_D0	-	PLAY1_OUT5	EVENTOUT
	PC9	UART5_CTS	OCTOSPI1_IO0	I3C2_SDA	FMC_CLE	SDMMC1_D1	-	PLAY1_IN3	EVENTOUT
	PC10	UART4_TX	OCTOSPI1_IO1	-	ETH_MII_TXD0/ETH_RMII_TXD0	SDMMC1_D2	-	PLAY1_IN0	EVENTOUT
	PC11	UART4_RX	OCTOSPI1_NCS2	-	-	SDMMC1_D3	-	-	EVENTOUT
	PC12	UART5_TX	-	ETH_PPS_OUT	-	SDMMC1_CK	-	-	EVENTOUT
	PC13	-	-	-	-	-	-	-	EVENTOUT
	PC14	-	-	-	-	-	-	-	EVENTOUT
PC15	-	-	-	-	-	-	-	EVENTOUT	



Table 13. Alternate functions AF8 to AF15

Port	AF8	AF9	AF10	AF11	AF12	AF13	AF14	AF15	
	ETH_/I3C2/LPUART1/SDMMC1/UART4/5/8	FDCAN1/2/FMC[NAND16]/FMC[NORmux]/FMC[NOR_RAM]/I2C3/I3C2/OCTOSPI	CRS/ETH_/FMC[NAND16]/I3C2/OCTOSPI/SDMMC1/USB_	ETH_/FMC[NAND16]/OCTOSPI/SDMMC1/UART7/USB_PD	ETH_/FMC[NAND16]/FMC[NORmux]/FMC[NOR_RAM]/FMC[SDRAM_16bit]/SDMMC1	COMP1/FMC[NAND16]/FMC[NORmux]/FMC[NOR_RAM]/UART8	COMP2/PLAY1_IN/PLAY1_OUT/TIM2/UART5/USART6	SYS	
D	PD0	UART4_RX	FDCAN1_RX	-	-	FMC_D2/FMC_AD2	-	-	EVENTOUT
	PD1	UART4_TX	FDCAN1_TX	-	ETH_MII_RX_DV/ETH_RMII_CRSDV	FMC_D3/FMC_AD3	-	-	EVENTOUT
	PD2	UART5_RX	-	-	-	SDMMC1_CMD	-	PLAY1_IN7	EVENTOUT
	PD3	-	-	-	ETH_10BT1S_TX	FMC_CLK	-	PLAY1_IN10	EVENTOUT
	PD4	-	-	OCTOSPI1_IO4	ETH_CLK	FMC_NOE	-	-	EVENTOUT
	PD5	-	FDCAN1_TX	OCTOSPI1_IO5	ETH_10BT1S_ED	FMC_NWE	-	-	EVENTOUT
	PD6	-	-	OCTOSPI1_IO6	SDMMC1_CK	FMC_NWAIT	-	-	EVENTOUT
	PD7	-	-	OCTOSPI1_IO7	SDMMC1_CMD	FMC_NE1/FMC_NCE	-	-	EVENTOUT
	PD8	ETH_MII_RXD0/ETH_B10T1S_RX_IN/ETH_RMII_RXD0	-	ETH_10BT1S_RX	-	FMC_D13/FMC_AD13	-	-	EVENTOUT
	PD9	-	FDCAN2_RX	ETH_10BT1S_TX	-	FMC_D14/FMC_AD14	-	PLAY1_IN3	EVENTOUT
	PD10	ETH_MII_CRSDV/ETH_B10T1S_ED_IN	-	ETH_10BT1S_ED	-	FMC_D15/FMC_AD15	-	-	EVENTOUT
	PD11	UART4_RX	OCTOSPI1_IO0	-	ETH_PTP_AUX_TS	FMC_A16/FMC_CLE	-	PLAY1_OUT0	EVENTOUT
	PD12	UART4_TX	OCTOSPI1_IO1	-	-	FMC_A17/FMC_ALE	-	PLAY1_OUT1	EVENTOUT
	PD13	-	OCTOSPI1_IO3	-	-	FMC_A18	-	PLAY1_OUT13	EVENTOUT
	PD14	UART8_CTS	-	-	-	FMC_D0/FMC_AD0	-	PLAY1_IN1	EVENTOUT
	PD15	UART8_RTS/UART8_DE	-	-	-	FMC_D1/FMC_AD1	-	PLAY1_OUT14	EVENTOUT



Table 13. Alternate functions AF8 to AF15

Port	AF8	AF9	AF10	AF11	AF12	AF13	AF14	AF15	
	ETH_/I3C2/LPUART1/SDMMC1/UART4/5/8	FDCAN1/2/FMC[NAND16]/FMC[NORmux]/FMC[NOR_RAM]/I2C3/I3C2/OCTOSPI	CRS/ETH_/FMC[NAND16]/I3C2/OCTOSPI/SDMMC1/USB_	ETH_/FMC[NAND16]/OCTOSPI/SDMMC1/UART7/USB_PD	ETH_/FMC[NAND16]/FMC[NORmux]/FMC[NOR_RAM]/FMC[SDRAM_16bit]/SDMMC1	COMP1/FMC[NAND16]/FMC[NORmux]/FMC[NOR_RAM]/UART8	COMP2/PLAY1_IN/PLAY1_OUT/TIM2/UART5/USART6	SYS	
E	PE0	UART8_RX	FDCAN1_RX	-	-	FMC_NBL0	-	-	EVENTOUT
	PE2	UART8_TX	OCTOSPI1_IO2	-	ETH_MII_TXD3	FMC_A23	-	PLAY1_OUT15	EVENTOUT
	PE3	-	-	-	-	FMC_A19	-	PLAY1_IN7	EVENTOUT
	PE4	-	-	-	ETH_MII_RXD0/ETH_B10T1S_RX_IN/ETH_RMII_RXD0	FMC_A20	UART8_TX	PLAY1_OUT7	EVENTOUT
	PE5	-	-	-	ETH_MII_RXD1/ETH_RMII_RXD1	FMC_A21	UART8_RX	PLAY1_OUT8	EVENTOUT
	PE6	-	-	-	-	FMC_A22	-	PLAY1_IN14	EVENTOUT
	PE7	-	-	OCTOSPI1_IO4	-	FMC_D4/FMC_AD4	-	PLAY1_IN2	EVENTOUT
	PE8	-	-	OCTOSPI1_IO5	-	FMC_D5/FMC_AD5	-	PLAY1_OUT7	EVENTOUT
	PE9	-	-	OCTOSPI1_IO6	-	FMC_D6/FMC_AD6	-	PLAY1_IN12	EVENTOUT
	PE10	-	-	OCTOSPI1_IO7	-	FMC_D7/FMC_AD7	-	PLAY1_OUT8	EVENTOUT
	PE11	-	-	-	-	FMC_D8/FMC_AD8	-	PLAY1_IN15	EVENTOUT
	PE12	-	-	-	ETH_MDIO	FMC_D9/FMC_AD9	-	PLAY1_OUT10	EVENTOUT
	PE13	-	-	-	-	FMC_D10/FMC_AD10	-	PLAY1_OUT11	EVENTOUT
	PE14	-	-	-	-	FMC_D11/FMC_AD11	-	PLAY1_OUT6	EVENTOUT
	PE15	-	-	-	-	FMC_D12/FMC_AD12	-	PLAY1_OUT9	EVENTOUT



Table 13. Alternate functions AF8 to AF15

Port	AF8	AF9	AF10	AF11	AF12	AF13	AF14	AF15	
	ETH_/I3C2/LPUART1/SDMMC1/UART4/5/8	FDCAN1/2/FMC[NAND16]/FMC[NORmux]/FMC[NOR_RAM]/I2C3/I3C2/OCTOSPI	CRS/ETH_/FMC[NAND16]/I3C2/OCTOSPI/SDMMC1/USB_	ETH_/FMC[NAND16]/OCTOSPI/SDMMC1/UART7/USB_PD	ETH_/FMC[NAND16]/FMC[NORmux]/FMC[NOR_RAM]/FMC[SDRAM_16bit]/SDMMC1	COMP1/FMC[NAND16]/FMC[NORmux]/FMC[NOR_RAM]/UART8	COMP2/PLAY1_IN/PLAY1_OUT/TIM2/UART5/USART6	SYS	
F	PF0	-	-	-	-	FMC_A0	-	-	EVENTOUT
	PF1	-	-	-	-	FMC_A1	-	-	EVENTOUT
	PF2	-	-	-	-	FMC_A2	-	-	EVENTOUT
	PF3	-	-	-	-	FMC_A3	-	-	EVENTOUT
	PF4	-	-	-	-	FMC_A4	-	-	EVENTOUT
	PF5	-	-	-	-	FMC_A5	-	-	EVENTOUT
	PF6	-	-	OCTOSPI1_IO3	-	FMC_NBL1	-	-	EVENTOUT
	PF7	-	-	OCTOSPI1_IO2	-	-	-	-	EVENTOUT
	PF8	-	-	OCTOSPI1_IO0	ETH_MII_TX_ER	-	-	PLAY1_OUT1	EVENTOUT
	PF9	-	-	OCTOSPI1_IO1	ETH_MDC	FMC_SDNWE	-	-	EVENTOUT
	PF10	-	OCTOSPI1_CLK	-	-	-	-	-	EVENTOUT
	PF11	-	OCTOSPI1_NCLK	-	-	FMC_NRAS	-	PLAY1_IN2	EVENTOUT
	PF12	-	-	-	-	FMC_A6	-	-	EVENTOUT
	PF13	-	-	-	-	FMC_A7	-	PLAY1_IN11	EVENTOUT
	PF14	-	-	-	-	FMC_A8	-	-	EVENTOUT
	PF15	-	-	-	ETH_CLK	FMC_A9	-	-	EVENTOUT



Table 13. Alternate functions AF8 to AF15

Port	AF8	AF9	AF10	AF11	AF12	AF13	AF14	AF15	
	ETH_/I3C2/LPUART1/SDMMC1/UART4/5/8	FDCAN1/2/FMC[NAND16]/FMC[NORmux]/FMC[NOR_RAM]/I2C3/I3C2/OCTOSPI	CRS/ETH_/FMC[NAND16]/I3C2/OCTOSPI/SDMMC1/USB_	ETH_/FMC[NAND16]/OCTOSPI/SDMMC1/UART7/USB_PD	ETH_/FMC[NAND16]/FMC[NORmux]/FMC[NOR_RAM]/FMC[SDRAM_16bit]/SDMMC1	COMP1/FMC[NAND16]/FMC[NORmux]/FMC[NOR_RAM]/UART8	COMP2/PLAY1_IN/PLAY1_OUT/TIM2/UART5/USART6	SYS	
G	PG0	-	-	-	-	FMC_A10	-	-	EVENTOUT
	PG1	-	-	-	-	FMC_A11	-	-	EVENTOUT
	PG2	-	-	-	-	FMC_A12	-	-	EVENTOUT
	PG3	-	-	ETH_MII_RX_ER	-	FMC_A13	-	PLAY1_IN8	EVENTOUT
	PG4	-	-	-	-	FMC_A14/FMC_BA0	-	-	EVENTOUT
	PG5	-	-	-	-	FMC_A15/FMC_BA1	-	PLAY1_IN5	EVENTOUT
	PG6	-	-	OCTOSPI1_NCS1	UCPD1_FRSTX	FMC_NE3	-	-	EVENTOUT
	PG7	-	-	ETH_10BT1S_TX	UCPD1_FRSTX	FMC_INT	-	-	EVENTOUT
	PG8	-	-	-	ETH_PPS_OUT	FMC_SDCLK	-	-	EVENTOUT
	PG9	-	OCTOSPI1_IO6	-	SDMMC1_D0	FMC_NE2/FMC_NCE	-	-	EVENTOUT
	PG10	-	-	-	SDMMC1_D1	FMC_NE3	-	-	EVENTOUT
	PG11	-	-	SDMMC1_D2	ETH_MII_TX_EN/ETH_RMII_TX_EN	-	-	-	EVENTOUT
	PG12	-	-	SDMMC1_D3	ETH_MII_TXD1/ETH_RMII_TXD1	FMC_NE4	-	-	EVENTOUT
	PG13	-	-	-	ETH_MII_TXD0/ETH_RMII_TXD0	FMC_A24	-	-	EVENTOUT
	PG14	-	OCTOSPI1_IO7	-	ETH_MII_TXD1/ETH_RMII_TXD1	FMC_A25	-	-	EVENTOUT
PG15	-	-	-	-	FMC_NCAS	-	-	EVENTOUT	
H	PH0	-	-	-	-	-	-	-	EVENTOUT
	PH1	-	-	-	-	-	-	-	EVENTOUT

5 Electrical characteristics

5.1 Parameter conditions

Unless otherwise specified, all voltages are referenced to V_{SS} .

5.1.1 Minimum and maximum values

Unless otherwise specified, the minimum and maximum values are guaranteed in the worst conditions of ambient temperature, supply voltage, and frequencies by tests in production on 100% of the devices with an ambient temperature at $T_J = 25^\circ\text{C}$ and $T_J = T_{J\text{max}}$ (given by the selected temperature range).

Data based on characterization results, design simulation and/or technology characteristics are indicated in the table footnotes, and are not tested in production. Based on characterization, the minimum and maximum values refer to sample tests and represent the mean value plus or minus three times the standard deviation (mean $\pm 3\sigma$).

5.1.2 Typical values

Unless otherwise specified, typical data are based on $T_J = 25^\circ\text{C}$, $V_{DD} = V_{DDA} = 3.3\text{ V}$ (for the $1.71 \leq V_{DD} \leq 3.6\text{ V}$ voltage range). They are given only as design guidelines and are not tested.

Typical ADC accuracy values are determined by characterization of a batch of samples from a standard diffusion lot over the full temperature range, where 95% of the devices have an error less than or equal to the value indicated (mean $\pm 2\sigma$).

5.1.3 Typical curves

Unless otherwise specified, all typical curves are given only as design guidelines, and are not tested.

5.1.4 Loading capacitor

The loading conditions used for pin parameter measurement are shown in [Figure 15](#).

5.1.5 Pin input voltage

The input voltage measurement on a pin of the device is described in [Figure 16](#).

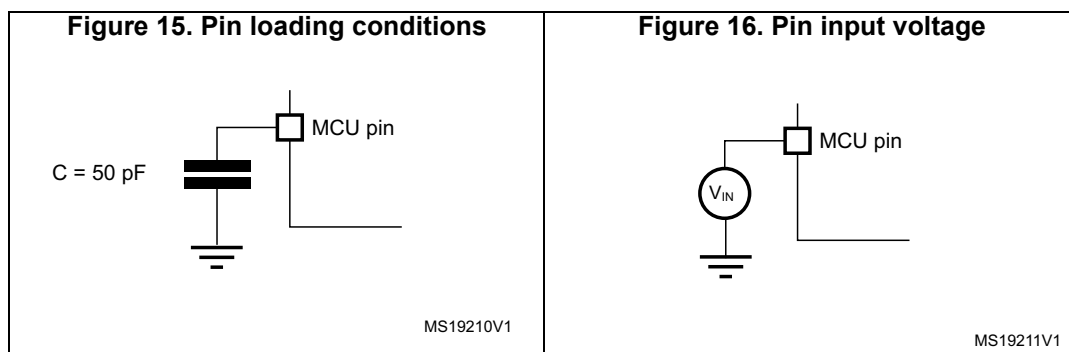

5.1.6 Power supply scheme

Figure 17. Power supply scheme

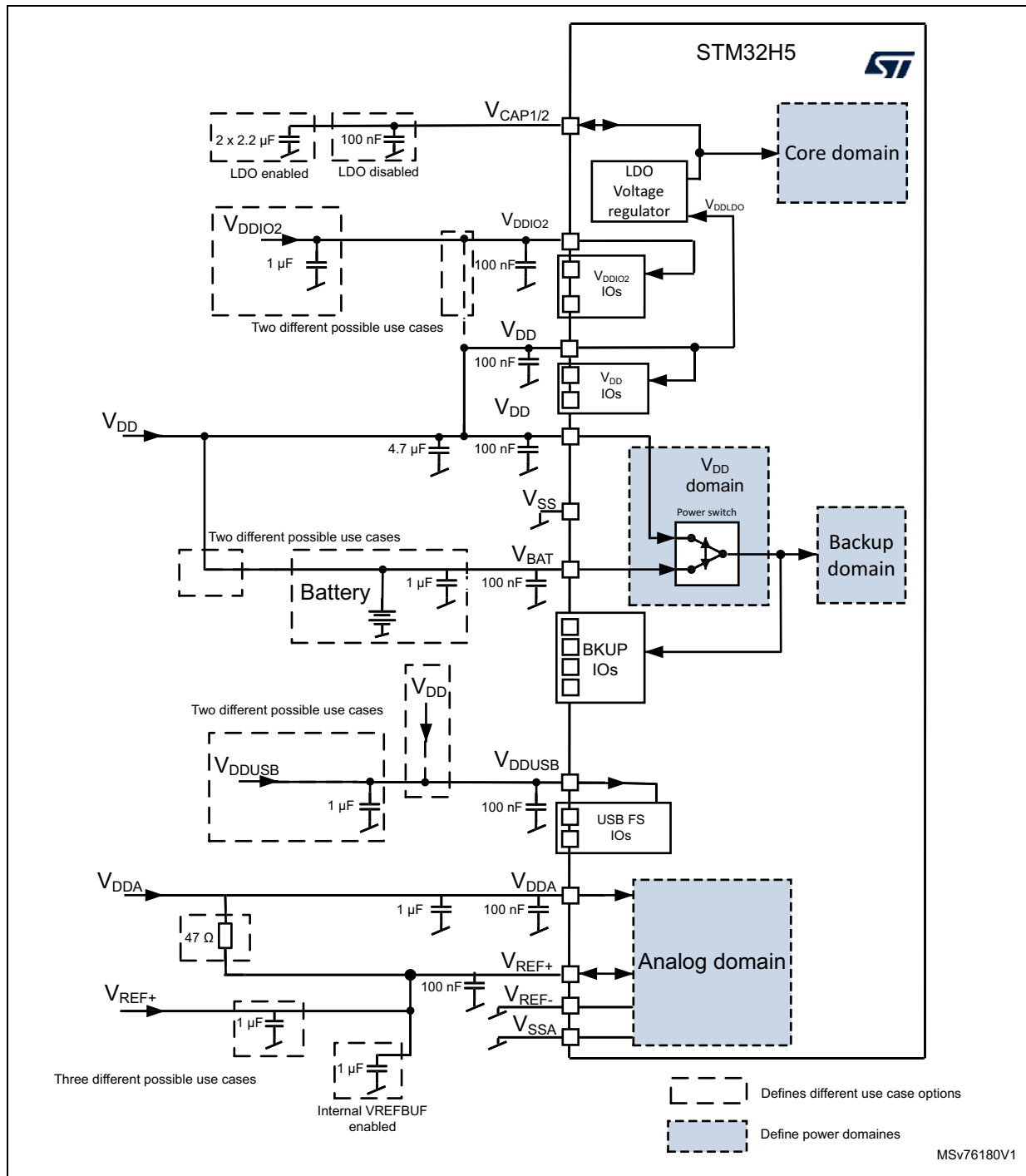

Note: Refer to “Getting started with STM32H5 Series hardware development” (AN5711) for more details.

Caution: Each power supply pair must be decoupled with filtering ceramic capacitors as shown above. These capacitors must be placed as close as possible to or below the appropriate pins on the underside of the PCB to ensure the good functionality of the device. It is not recommended to remove filtering capacitors to reduce PCB size or cost. This might cause incorrect operation of the device.

5.2 Absolute maximum ratings

Stresses above the absolute maximum ratings listed in [Table 14](#), [Table 15](#), and [Table 16](#) may cause permanent damage to the device. These are stress ratings only and the functional operation of the device at these conditions is not implied. Exposure to maximum rating conditions for extended periods may affect device reliability. Device mission profile (application conditions) is compliant with JEDEC JESD47 Qualification Standard, extended mission profiles are available on demand.

Table 14. Voltage characteristics⁽¹⁾

Symbol	Ratings	Min	Max	Unit
$V_{DDx} - V_{SS}$	External main supply voltage (including V_{DDA} , V_{DDUSB} , V_{DDIO2} ⁽²⁾⁽³⁾⁽⁴⁾ , V_{BAT} , and V_{REF+})	-0.3	4.0	V
V_{DDIOx} ⁽⁴⁾ - V_{SS}	I/O supply when HSLV ⁽⁵⁾ = 0	-0.3	4.0	V
	I/O supply when HSLV ⁽⁵⁾ = 1	-0.3	2.75	
V_{IN} ⁽⁶⁾	Input voltage on FT_XXX pins except FT_c pins	$V_{SS} - 0.3$	$\min(\min(V_{DD}, V_{DDA}, V_{DDUSB}, V_{DDIO2}) + 4.0, 6.0 \text{ V})$ ⁽⁵⁾⁽⁷⁾	V
	Input voltage on FT_t in V_{BAT} mode	$V_{SS} - 0.3$	$\min(\min(V_{BAT}, V_{DDA}, V_{DDUSB}, V_{DDIO2}) + 4.0 \text{ V}, 6.0 \text{ V})$	
	Input voltage on TT_XX pins	$V_{SS} - 0.3$	4.0	
	Input voltage on BOOT0 pin	V_{SS}	$\min(\min(V_{DD}, V_{DDA}, V_{DDUSB}, V_{DDIO2}) + 4.0, 6.0 \text{ V})$ ⁽⁷⁾	
	Input voltage on FT_c pins	$V_{SS} - 0.3$	5.5	
	Input voltage on any other pins	$V_{SS} - 0.3$	4.0	
$V_{REF+} - V_{DDA}$	Allowed voltage difference for $V_{REF+} > V_{DDA}$	-	0.4	
$ \Delta V_{DDx} $	Variations between different V_{DDx} power pins of the same domain	-	50.0	mV
$ V_{SSx} - V_{SS} $	Variations between all the different ground pins	-	50.0	

1. All main power (V_{DD} , V_{DDA} , V_{DDUSB} , V_{DDIO2} , V_{REF+} , V_{BAT}) and ground (V_{SS} , V_{SSA}) pins must always be connected to the external power supply, in the permitted range.
2. HSLV = High-speed low-voltage mode. Refer to General purpose I/Os (GPIO) section of RM0481.
3. If HSLV = 0.
4. V_{DDIO1} or V_{DDIO2} . $V_{DDIO1} = V_{DD}$.
5. This formula must be applied on power supplies related to the I/O structure described by the pin definition table.
6. V_{IN} maximum must always be respected. Refer to the maximum allowed injected current values.
7. To sustain a voltage higher than 4 V the internal pull-up/pull-down resistors must be disabled.

Prerelease product(s)

Table 15. Current characteristics

Symbol	Ratings	Max	Unit
$\Sigma I_{V_{DD}}$	Total current into sum of all V_{DD} power lines (source) ⁽¹⁾	350	mA
$\Sigma I_{V_{SS}}$	Total current out of sum of all V_{SS} ground lines (sink) ⁽¹⁾	350	
$I_{V_{DD}}$	Maximum current into each V_{DD} power pin (source) ⁽¹⁾	100	
$I_{V_{SS}}$	Maximum current out of each V_{SS} ground pin (sink) ⁽¹⁾	100	
$I_{I/O(PIN)}$	Output current sunk/sourced by any I/O and control pin	20	
$\Sigma I_{I/O(PIN)}$	Total output current sunk by sum of all I/Os and control pins ⁽²⁾	140	
	Total output current sourced by sum of all I/Os and control pins ⁽²⁾	140	
$I_{INJ(PIN)}^{(3)(4)}$	Injected current on FT_xxx, TT_xx, NRST pins	-5 / 0	
$\Sigma I_{INJ(PIN)} $	Total injected current (sum of all I/Os and control pins) ⁽⁵⁾	±25	

1. All main power (V_{DD} , V_{DDA} , V_{DDIO2} , and V_{BAT}) and ground (V_{SS} , V_{SSA}) pins must always be connected to the external power supplies, in the allowed range.
2. This current consumption must be correctly distributed over all I/Os and control pins. The total output current must not be sunk/sourced between two consecutive power supply pins referring to high pin count LQFP packages.
3. Positive injection (when $V_{IN} > V_{DDIOx}$) is not possible on these I/Os, and does not occur for input voltages lower than the specified maximum value.
4. A negative injection is induced by $V_{IN} < V_{SS}$. $I_{INJ(PIN)}$ must never be exceeded. Refer to [Table 14](#) for the minimum allowed input voltage values.
5. When several inputs are submitted to a current injection, the maximum $\Sigma |I_{INJ(PIN)}|$ is the absolute sum of the negative injected currents (instantaneous values).

Table 16. Thermal characteristics

Symbol	Ratings	Value	Unit
T_{STG}	Storage temperature range	-65 to +150	°C
T_J	Maximum junction temperature	140 ⁽¹⁾	°C

1. The junction temperature is limited to 105°C in the VOS0 voltage range.

5.3 Operating conditions

5.3.1 General operating conditions

Table 17. General operating conditions

Symbol	Parameter	Operating conditions	Min	Typ	Max	Unit
V_{DD}	Standard operating voltage	HSLV ⁽¹⁾ = 0	1.71 ⁽²⁾	-	3.6	V
		HSLV ⁽¹⁾ = 1	1.71 ⁽²⁾	-	2.7	
V_{DDIO2}	PB8, PB9, PD6, PD7, PG[9:14] I/Os supply voltage	At least one I/O in PB8, PB9, PD6, PD7, PG[9:14] is used, HSLV ⁽¹⁾ = 0	1.08	-	3.6	V
		At least one I/O in PB8, PB9, PD6, PD7, PG[9:14] is used, HSLV ⁽¹⁾ = 1	1.08	-	2.7	
		PB8, PB9, PD6, PD7, PG[9:14] are not used	0	-	3.6	

Prerelease product(s)

Table 17. General operating conditions (continued)

Symbol	Parameter	Operating conditions	Min	Typ	Max	Unit
V _{DDUSB}	USB supply voltage	USB is used	3.0	-	3.6	V
		USB is not used	0	-	3.6	
V _{DDA}	Analog supply voltage	ADC or COMP is used	1.62	-	3.6	V
		DAC is used	1.8	-		
		VREFBUF is used	2.1	-		
		ADC, DAC, and VREFBUF are not used	0	-		
V _{BAT}	Backup domain supply voltage	-	1.2	-	3.6	V
V _{IN}	I/O input voltage	All I/Os except FT_c and TT_xx	-0.3	-	min (min (V _{DD} , V _{DDA} , V _{DDUSB} , V _{DDIO2}) + 3.6V, 5.5 V) (3)(4)	V
		Input voltage on FT_t in VBAT mode	-0.3	-	min (min (V _{BAT} , V _{DDA} , V _{DDUSB} , V _{DDIO2}) + 3.6 V, 5.5 V) (3)(4)	
		FT_c I/O	-0.3	-	5.0	
		TT_xx I/O	-0.3	-	V _{DDIOx} + 0.3	
V _{CORE}	Internal regulator ON	VOS0 ⁽⁵⁾ (max frequency for AHB and APB: 250 MHz)	1.30	1.35	1.40	V
		VOS1 (max frequency for AHB and APB: 200 MHz)	1.15	1.20	1.26	
		VOS2 (max frequency for AHB and APB: 150 MHz)	1.05	1.10	1.15	
		VOS3 (max frequency for AHB and APB: 100 MHz)	0.95	1.00	1.05	
	Regulator OFF: external V _{CORE} voltage must be supplied from external regulator on VCAP pins	VOS0 ⁽⁵⁾	1.32	1.35	1.40	V
		VOS1	1.17	1.20	1.26	
		VOS2	1.07	1.10	1.15	
		VOS3	0.97	1.00	1.05	
	Stop mode	SVOS3	-	1.0	-	V
		SVOS4	-	0.9	-	
SVOS5		-	0.74	-		

Prerelease product(s)

Table 17. General operating conditions (continued)

Symbol	Parameter	Operating conditions	Min	Typ	Max	Unit
f _{HCLK}	AHB clock frequency	VOS0 ⁽⁵⁾	-	-	250	MHz
		VOS1	-	-	200	
		VOS2	-	-	150	
		VOS3	-	-	100	
f _{PCLKx} (x=1,2,3)	APB1, APB2, APB3 clock frequency	VOS0 ⁽⁵⁾	-	-	250	MHz
		VOS1	-	-	200	
		VOS2	-	-	150	
		VOS3	-	-	100	
P _D	Power dissipation at T _A = 85 or 105°C for suffix 6 or 7 versions ⁽⁶⁾	LQFP48	See Table 142 for appropriate thermal resistance and package. Power dissipation is calculated according to ambient temperature (T _A), maximum junction temperature (T _J), and selected thermal resistance.			mW
		LQFP64				
		LQFP100				
		LQFP100-EP				
		LQFP144				
		LQFP144-EP				
		UFQFPN48				
		UFBGA100				
		UFBGA144				
		WLCSP63				
P _D	Power dissipation at T _A = 125°C for suffix 3 version ⁽⁶⁾	LQFP48	See Table 142 for appropriate thermal resistance and package. Power dissipation is calculated according to ambient temperature (T _A), maximum junction temperature (T _J), and selected thermal resistance.			mW
		LQFP64				
		LQFP100				
		LQFP100-EP				
		LQFP144				
		LQFP144-EP				
		UFQFPN48				
		UFBGA100				
		UFBGA144				
		WLCSP63				

Prerelease product(s)

Table 17. General operating conditions (continued)

Symbol	Parameter	Operating conditions	Min	Typ	Max	Unit
T _A	Ambient temperature for the suffix 3 version	Maximum power dissipation	-40	-	125	°C
	Ambient temperature for the suffix 6 version	Maximum power dissipation	-40	-	85	
		In LDO bypass mode	-40	-	125	
	Ambient temperature for the suffix 7 version	Maximum power dissipation	-40	-	105	
In LDO bypass mode		-40	-	125		
T _J	Junction temperature range	VOS0	-40	-	105	°C
		VOS1, VOS2, and VOS3	-40	-	140	

1. HSLV = High-speed low-voltage mode. Refer to General-purpose I/Os (GPIO) section of RM0481.
2. When RESET is released functionality is guaranteed down to BOR level 0 minimum voltage.
3. This formula must be applied on power supplies related to the I/O structure described by the pin definition table. Maximum I/O input voltage is the smallest value between min (V_{DD}, V_{DDA}, V_{DDIO2}) + 3.6 V and 5.5 V.
4. For operation with voltages higher than min (V_{DD}, V_{DDA}, V_{DDIO2}) + 0.3V, the internal pull-up and pull-down resistors must be disabled.
5. In VOS0 mode the max T_J is 105°C.
6. If T_A is lower, higher P_D values are allowed as long as T_J does not exceed T_{Jmax} (see [Table 16](#)).

Table 18. Maximum allowed clock frequencies

Symbol ⁽¹⁾⁽²⁾	Parameter	VOS0	VOS1	VOS2	VOS3	Unit
f _{CPU}	CPU	250	200	150	100	MHz
f _{HCLK}	AHB	250	200	150	100	
f _{PCLK}	APB	250	200	150	100	
-	FMC	250	200	150	100	
f _{octospi_ker_ck}	OCTOSPI	250	200	150	100	
f _{sdmmc_ker_ck}	SDMMC	250	200	150	100	
-	HDMI_CEC	4	4	4	4	
f _{fdcan_ker_ck}	FDCAN	250	200	150	100	
f _{i2c_ker_ck}	I2C[1:3]	250	200	150	100	
f _{i3c_ker_ck}	I3C[1:2]	250	200	150	100	
f _{lptim_ker_ck}	LPTIM[1:2]	250	200	150	100	
f _{tim_ker_ck}	TIM[1:8], TIM12, TIM15	250	200	150	100	MHz
	TIM6/17	64	64	64	64	
f _{rng_clk}	RNG	50	50	50	50	MHz
f _{play_ker_ck}	PLAY1	200	150	100	64	MHz

Prerelease product(s)

Table 18. Maximum allowed clock frequencies (continued)

Symbol ⁽¹⁾⁽²⁾	Parameter	VOS0	VOS1	VOS2	VOS3	Unit
f _{spi_ker_ck}	SPI(I2S)1,2,3	125	100	75	50	MHz
	SPI4	125	100	75	50	
f _{lpuart_ker_ck}	LPUART1	250	200	150	100	
f _{usart_ker_ck}	USART/UART	250	200	150	100	MHz
f _{usb_ker_ck}	USB FS	50	50	50	50	MHz
f _{adc_ker_ck_input}	ADC	250	200	150	100	MHz
f _{adc_ker_ck} ⁽³⁾	ADC	125	100	75	50	
f _{dac_ker_ck}	DAC	250	200	150	100	MHz
f _{ucpd_ker_ck}	UCPD	64	64	64	64	MHz
f _{rtc_ker_ck}	RTC	1	1	1	1	MHz

1. Specified by design - Not tested in production.
2. The maximum kernel clock frequencies can be limited by the maximum peripheral clock frequency (refer to each peripheral electrical characteristics).
3. This maximum kernel clock frequency does not consider the maximum ADC clock frequency (refer to [Table 90](#)).

5.3.2 VCAP external capacitor

The stabilization for the embedded LDO regulator is achieved by connecting an external capacitor C_{EXT} (whose value is specified in [Table 19](#)) to the VCAPx (one or two pins, depending upon the package). Two external capacitors must be connected to VCAP pins (refer to AN5711 - Getting started with STM32H5 MCU hardware development).

Figure 18. External capacitor C_{EXT}

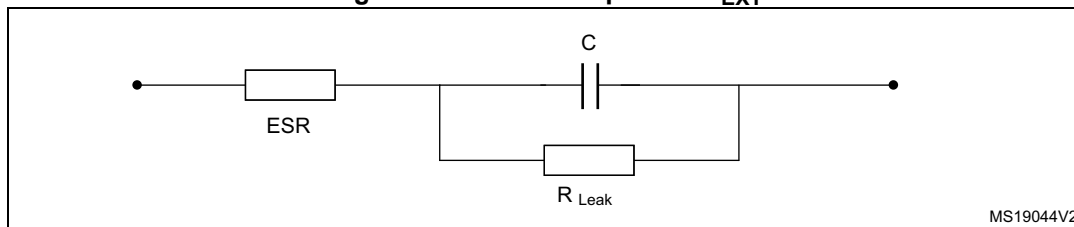

MS19044V2

Table 19. Supply voltage and maximum frequency configuration

Symbol	Parameter	Conditions
C _{EXT}	External capacitor for LDO enabled	2.2 μF ⁽¹⁾
ESR	Equivalent series resistance of the external capacitor	< 100 mΩ

1. This value corresponds to C_{EXT} typical value. A variation of ±20% is tolerated

Prerelease product(s)

5.3.3 Operating conditions at power-up/down

Subject to general operating conditions for T_A .

Table 20. Operating conditions at power-up/down (regulator ON)

Symbol	Parameter	Min	Max	Unit
T_{VDD}	V_{DD} rise time rate	0	∞	$\mu\text{s/V}$
	V_{DD} fall time rate	10	∞	
T_{VDDA}	V_{DDA} rise time rate	0	∞	
	V_{DDA} fall time rate	10	∞	
T_{VDDUSB}	T_{VDDUSB} rise time rate	0	∞	
	T_{VDDUSB} fall time rate	10	∞	
T_{VDDIO2}	T_{VDDIO2} rise time rate	0	∞	
	T_{VDDIO2} fall time rate	10	∞	
T_{VBAT}	T_{VBAT} rise time rate	0	∞	
	T_{VBAT} fall time rate	10	∞	

5.3.4 Embedded reset and power control block characteristics

The parameters given in [Table 21](#) are derived from tests performed under ambient temperature and V_{DD} supply voltage conditions summarized in [Table 17](#).

Table 21. Embedded reset and power control block characteristics⁽¹⁾

Symbol	Parameter	Conditions	Min	Typ	Max	Unit
$t_{RSTTEMPO}^{(2)}$	Reset temporization after BOR0 detection	V_{DD} rising	-	377	550	μs
$V_{POR/PDR}$	Power-on/down reset threshold (BORH_EN =0)	Rising edge	1.62	1.67	1.71	V
		Falling edge	1.58	1.62	1.68	
V_{BOR1}	Brownout reset threshold 1 (BORH_EN =1)	Rising edge	2.04	2.10	2.15	V
		Falling edge	1.95	2.00	2.06	
V_{BOR2}	Brownout reset threshold 2 (BORH_EN =1)	Rising edge	2.34	2.41	2.47	
		Falling edge	2.25	2.31	2.37	
V_{BOR3}	Brownout reset threshold 3 (BORH_EN =1)	Rising edge	2.63	2.70	2.78	
		Falling edge	2.54	2.61	2.68	

Prerelease product(s)

Table 21. Embedded reset and power control block characteristics⁽¹⁾ (continued)

Symbol	Parameter	Conditions	Min	Typ	Max	Unit	
V _{PVD0}	PVD threshold 0	Rising edge	1.90	1.96	2.01	V	
		Falling edge	1.81	1.86	1.91		
V _{PVD1}	PVD threshold 1	Rising edge	2.05	2.10	2.16		
		Falling edge	1.96	2.01	2.06		
V _{PVD2}	PVD threshold 2	Rising edge	2.19	2.26	2.32		
		Falling edge	2.10	2.15	2.21		
V _{PVD3}	PVD threshold 3	Rising edge	2.35	2.41	2.47		
		Falling edge	2.25	2.31	2.37		
V _{PVD4}	PVD threshold 4	Rising edge	2.49	2.56	2.62		
		Falling edge	2.39	2.45	2.51		
V _{PVD5}	PVD threshold 5	Rising edge	2.64	2.71	2.78		
		Falling edge	2.55	2.61	2.68		
V _{PVD6}	PVD threshold 6	Rising edge	2.78	2.86	2.94		
		Falling edge	2.69	2.76	2.83		
V _{POR/PDR}	Hysteresis for power-on/down reset	Hysteresis in Run mode	-	43	-	mV	
V _{hyst_BOR_PVD}	Hysteresis voltage of BOR (unless BORH_EN = 0) and PVD	-	-	100	-		
I _{DD_BOR_PVD} ⁽²⁾	BOR and PVD consumption from V _{DD}	-	-	-	0.630	μA	
I _{DD_POR_PDR}	POR and PDR consumption from V _{DD}	-	0.8	-	1.2		
V _{AVD0}	V _{DDA} voltage monitor 0 threshold	Rising edge	1.66	1.71	1.76	V	
		Falling edge	1.56	1.61	1.66		
V _{AVD1}	V _{DDA} voltage monitor 1 threshold	Rising edge	2.06	2.12	2.19		
		Falling edge	1.96	2.02	2.08		
V _{AVD2}	V _{DDA} voltage monitor 2 threshold	Rising edge	2.42	2.50	2.58		
		Falling edge	2.35	2.42	2.49		
V _{AVD3}	V _{DDA} voltage monitor 3 threshold	Rising edge	2.74	2.83	2.91		
		Falling edge	2.64	2.72	2.80		
V _{IO2VM}	V _{DDIO2} voltage monitor threshold	-	-	0.9	-		V
V _{hyst_AVD}	Hysteresis of V _{DDA} voltage monitor	-	-	100	-		mV
I _{DD_AVD_IO2VM} ⁽²⁾	Power voltage detector consumption from V _{DD} (AVD, IO2VM)	-	-	-	0.25	μA	
I _{DD_AVD_A} ⁽²⁾	Analog voltage detector consumption from V _{DDA} (resistor bridge)	-	-	-	0.25		

1. Evaluated by characterization and not tested in production, unless otherwise specified.
2. Specified by design - Not tested in production

Prerelease product(s)

5.3.5 Embedded reference voltage

The parameters given in [Table 22](#) are derived from tests performed under the ambient temperature and supply voltage conditions summarized in [Table 17](#).

Table 22. Embedded reference voltage

Symbol	Parameter	Conditions	Min	Typ	Max	Unit
$V_{REFINT}^{(1)}$	Internal reference voltage	$-40^{\circ}\text{C} < T_J < +140^{\circ}\text{C}$	1.180	1.216	1.255	V
$t_{S_vrefint}^{(2)(3)}$	ADC sampling time when reading the internal reference voltage	-	4.3	-	-	μs
$t_{start_vrefint}^{(3)}$	Start time of reference voltage buffer when the ADC is enabled	-	-	-	4.4	
$I_{refbuf}^{(3)}$	Reference buffer consumption for ADC	$V_{DD} = 3.3\text{ V}$	9	13.5	23	μA
$\Delta V_{REFINT}^{(3)}$	Internal reference voltage spread over the temperature range	$-40^{\circ}\text{C} < T_J < +130^{\circ}\text{C}$	-	5	15	mV
T_{Ccoeff}	Average temperature coefficient	Average temperature coefficient	-	20	70	ppm/°C
$V_{DDcoeff}$	Average voltage coefficient	$3.0\text{ V} < V_{DD} < 3.6\text{ V}$	-	10	1370	ppm/V
$V_{REFINT_DIV1}^{(3)}$	1/4 reference voltage	-	-	25	-	% V_{REFINT}
$V_{REFINT_DIV2}^{(3)}$	1/2 reference voltage		-	50	-	
$V_{REFINT_DIV3}^{(3)}$	3/4 reference voltage		-	75	-	

1. V_{REFINT} does not take into account package and soldering effects.
2. The shortest sampling time for the application can be determined by multiple iterations.
3. Specified by design - Not tested in production.

Table 23. Internal reference voltage calibration value

Symbol	Parameter	Memory address
V_{REFINT_CAL}	Raw data acquired at 30°C, $V_{DDA} = 3.3\text{ V}$	0x08FF F810 - 0x08FF F811

5.3.6 Supply current characteristics

The current consumption is a function of several parameters and factors such as the operating voltage, ambient temperature, I/O pin loading, device software configuration, operating frequencies, I/O pin switching rate, program location in memory, and executed binary code.

All the run-mode current consumption measurements given in this section are performed with a CoreMark code.

Typical and maximum current consumption

The MCU is placed under the following conditions:

- All I/O pins are in analog input mode.
- All peripherals are disabled except when explicitly mentioned.

- The flash memory access time is adjusted with the minimum wait-state number, depending on the f_{HCLK} frequency (refer to the tables detailing recommended number of wait states and programming delay available in the reference manual).
- When the peripherals are enabled, the AHB clock frequency is the CPU frequency, and the APB clock frequency is AHB frequency.

The parameters given in the following tables are derived from tests performed under supply voltage conditions summarized in [Table 17](#), and, unless otherwise specified, at ambient temperature.

The maximum current consumption is given for LDO regulator ON.

Table 24. Typical and maximum current consumption in Run mode, code with data processing running from flash memory, 2-way instruction cache ON, PREFETCH ON

Symbol	Parameter	Conditions	f_{HCLK} (MHz)	Typ LDO	Max ⁽¹⁾⁽²⁾					Unit			
					$T_J = 25^\circ\text{C}$	$T_J = 85^\circ\text{C}$	$T_J = 105^\circ\text{C}$	$T_J = 130^\circ\text{C}$	$T_J = 140^\circ\text{C}$				
$I_{DD(\text{Run})}$	Supply current in Run mode	All peripherals disabled	VOS0	250	34.3	36	54	69	-	-	mA		
				215	29.9	31	50	65	-	-			
				200	27.0	29	48	63	-	-			
			VOS1	200	23.6	25	39	51	74	91			
				180	21.7	22	37	48	72	89			
				168	20.3	21	36	47	70	88			
			VOS2	150	17.9	19	34	45	68	86			
				150	16.4	17	30	39	59	74			
			VOS3	100	11.6	12	25	34	54	69			
				100	10.6	11	21	29	45	57			
				60	6.8	7	17	26	42	54			
			All peripherals enabled	VOS0	25	3.3	4	14	22	39		51	
		250			81.5	86	107	122	-	-			
		215			70.4	74	93	107	-	-			
		VOS1		200	65.1	69	88	103	-	-			
				200	56.9	59	75	86	110	123			
				180	51.6	54	69	81	104	118			
		VOS2		150	42.9	45	60	71	94	112			
				150	39.1	41	53	63	83	98			
		VOS3		100	26.5	28	40	50	70	85			
				100	24.1	26	36	44	60	72			
				60	15.0	16	26	34	51	63			
						25	6.8	8	18	26		42	55

1. Evaluated by characterization - Not tested in production.

Prerelease product(s)

2. The maximum values are given for LDO regulator ON.

Table 25. Typical and maximum current consumption in Run mode, code with data processing running from flash memory, 1-way instruction cache ON, PREFETCH ON

Symbol	Parameter	Conditions	f _{HCLK} (MHz)	Typ LDO	Max ⁽¹⁾⁽²⁾					Unit	
					T _J = 25°C	T _J = 85°C	T _J = 105°C	T _J = 130°C	T _J = 140°C		
I _{DD} (Run)	Supply current in Run mode	All peripherals disabled	VOS0	250	31.4	33	52	66	-	-	mA
				200	24.6	27	46	60	-	-	
			VOS1	200	21.7	23	37	49	72	89	
				180	19.8	21	35	47	70	87	
			VOS2	150	16.4	18	32	44	67	84	
				150	15.0	16	28	38	58	72	
			VOS3	100	10.6	11	24	34	53	68	
				100	9.5	10	20	28	44	57	
			25	3.1	4	14	22	39	51		

1. Evaluated by characterization - Not tested in production.
2. The maximum values are given for LDO regulator ON.

Table 26. Typical and maximum current consumption in Run mode, code with data processing running from SRAM with cache 1-way

Symbol	Parameter	Conditions	f _{HCLK} (MHz)	Typ LDO	Max ⁽¹⁾⁽²⁾					Unit	
					T _J = 25°C	T _J = 85°C	T _J = 105°C	T _J = 130°C	T _J = 140°C		
I _{DD} (Run)	Supply current in Run mode	All peripherals disabled	VOS0	250	30.4	32	58	73	-	-	mA
				215	26.1	28	54	69	-	-	
				200	24.1	26	52	67	-	-	
			VOS1	200	20.7	22	42	54	83	100	
				180	19.3	20	40	52	81	98	
			VOS2	150	15.9	17	37	49	78	95	
				150	14.5	16	34	44	68	83	
			VOS3	100	10.1	12	29	39	64	79	
				100	9.2	10	24	32	52	64	
			25	60	6.0	7	21	29	49	61	
				25	3.0	4	18	26	47	59	

1. Evaluated by characterization - Not tested in production.
2. The maximum values are given for LDO regulator ON.

Table 27. Typical and maximum current consumption in Run mode, code with data processing running from SRAM with cache 2-way

Symbol	Parameter	Conditions	f _{HCLK} (MHz)	Typ LDO	Max ⁽¹⁾⁽²⁾					Unit	
					T _J = 25°C	T _J = 85°C	T _J = 105°C	T _J = 130°C	T _J = 140°C		
I _{DD(Run)}	Supply current in Run mode	All peripherals disabled	VOS0	250	33.8	35	54	69	-	-	mA
				215	29.0	31	50	64	-	-	
				200	26.5	29	48	62	-	-	
			VOS1	200	23.2	26	41	52	76	89	
				180	21.2	22	36	48	71	89	
				168	19.8	21	35	47	70	87	
			VOS2	150	17.4	19	33	45	68	85	
				150	15.9	17	29	39	59	73	
			VOS3	100	11.1	12	24	34	54	69	
				100	10.1	11	21	29	45	57	
				60	6.6	7	17	25	42	54	
				25	3.2	4	14	22	39	51	

1. Evaluated by characterization - Not tested in production.
2. The maximum values are given for LDO regulator ON.

Prerelease product(s)

Table 28. Typical consumption in Run mode with CoreMark running from flash memory and SRAM⁽¹⁾

Symbol	Parameter	Conditions		f _{HCLK} (MHz)	Typ LDO	Unit	Typ LDO	Unit	
		Peripheral	Code						
I _{DD(Run)}	Supply current in Run mode	All peripherals disabled, instruction cache 2-way, prefetch ON	FLASH	250	34.3	mA	137.0	μA/MHz	
				200	23.6		118.2		
				168	20.3		120.6		
				150	16.4		109.4		
				100	10.6		106.2		
			All peripherals disabled, instruction cache 1-way, prefetch ON	FLASH	250		31.4		125.5
					200		21.7		108.6
					150		15.0		99.7
					100		9.5		95.1
					All peripherals disabled, instruction cache 2-way		SRAM		250
		200	23.2	115.8					
		168	19.8	117.8					
		150	15.9	106.2					
		100	10.1	101.3					
		All peripherals disabled, instruction cache 1-way	SRAM	250			30.4		121.6
				200			20.7		103.7
				150			14.5		96.5
				100			9.2		92.2

1. Evaluated by characterization - Not tested in production.

Prerelease product(s)

Table 29. Typical consumption in Run mode with SecureMark running from flash memory and SRAM⁽¹⁾

Symbol	Parameter	Conditions		f _{HCLK} (MHz)	Typ LDO	Unit	Typ LDO	Unit
		Peripheral	Code					
I _{DD(Run)}	Supply current in Run mode	All peripherals disabled, instruction cache 2-way, prefetch ON	FLASH	250	39.6	mA	158.4	µA/ MHz
				180	25.1		139.5	
				168	23.2		137.9	
				150	19.0		126.6	
				100	12.1		120.6	
		All peripherals disabled, instruction cache 1-way, prefetch ON	FLASH	250	37.3		149.0	
				180	23.7		131.7	
				168	21.9		130.5	
				150	18.0		120.0	
				100	11.4		114.3	

1. Evaluated by characterization - Not tested in production.

Table 30. Typical and maximum current consumption in Sleep mode

Symbol	Parameter	Conditions	f _{HCLK} (MHz)	Typ LDO	Max ^{(1) (2)}					Unit	
					T _J = 25°C	T _J = 85°C	T _J = 105°C	T _J = 130°C	T _J = 140°C		
I _{DD(sleep)}	Supply current in sleep mode	All peripherals disabled	VOS0	250	8.8	14	32	43	-	-	mA
				200	6.8	12	30	41	-	-	
			VOS1	200	5.9	10	22	30	48	59	
				180	5.7	9	22	29	47	58	
				168	5.1	9	21	28	47	57	
			VOS2	150	4.6	8	20	28	46	57	
				150	4.2	7	18	24	39	48	
			VOS3	100	3.2	5	16	22	37	46	
				100	2.9	5	13	18	31	39	
			60	2.2	3	12	17	30	37		

1. Evaluated by characterization - Not tested in production.

2. The maximum values are given for LDO regulator ON.

Prerelease product(s)

Table 31. Typical and maximum current consumption in Stop mode

Symbol	Parameter	Conditions		Typ LDO	Max ^{(1) (2)}					Unit
					T _J = 25°C	T _J = 85°C	T _J = 105°C	T _J = 130°C	T _J = 140°C	
I _{DD(stop)}	Supply current in Stop	Flash memory in low power mode, SRAMs ON	SVOS3	0.26	1.3	9.7	16.4	31.0	39.4	mA
			SVOS4	0.20	0.9	7.5	12.8	24.8	31.7	
			SVOS5	0.15	0.6	5.4	9.5	18.9	24.4	
		Flash memory in normal mode, SRAMs ON	SVOS3	0.28	1.3	9.7	16.4	31.1	39.4	
			SVOS4	0.21	0.9	7.5	12.8	24.8	31.7	
		Flash memory in low power mode, SRAMs OFF except SRAM2 16 Kbytes ON	SVOS3	0.23	1.2	8.9	15.0	28.3	35.9	
			SVOS4	0.17	0.8	6.9	11.7	22.6	28.8	
			SVOS5	0.12	0.5	4.7	8.2	16.2	20.9	
		Flash memory in low power mode, SRAMs OFF except SRAM2 ON	SVOS3	0.24	1.2	9.1	15.3	29.0	36.7	
			SVOS4	0.18	0.9	7.0	12.0	23.1	29.5	
			SVOS5	0.13	0.5	4.8	8.5	16.9	21.8	

1. Evaluated by characterization - Not tested in production.
2. The maximum values are given for LDO regulator ON.

Table 32. Typical and maximum current consumption in Standby mode

Symbol	Parameter	Conditions		Typ ⁽¹⁾				Max ⁽¹⁾					Unit
		Backup RAM	RTC and LSE ⁽²⁾	1.8 V	2.4 V	3 V	3.3 V	T _J = 25°C	T _J = 85°C	T _J = 105°C	T _J = 130°C	T _J = 140°C	
I _{DD(standby)}	Supply current in Standby mode, IWDG OFF	OFF	OFF	2.8	3	3.3	3.4	3.9	8.9	16.3	41.8	61.9	µA
		ON	OFF	3.9	4.2	4.6	4.8	5.7	15.3	26.2	63.3	88.8	
		OFF	ON	3.1	3.4	3.7	3.9	4.9	10.1	17.6	43.8	64.2	
		ON	ON	4.4	4.7	5.1	5.4	6.7	16.5	27.5	65.3	91.1	

1. Evaluated by characterization - Not tested in production.
2. LSE is in medium-low drive mode.

Prerelease product(s)

Table 33. Typical and maximum current consumption in V_{BAT} mode

Symbol	Parameter	Conditions		Typ ⁽¹⁾				Max ⁽¹⁾					Unit
		Backup RAM	RTC and	1.8 V	2.4 V	3 V	3.3 V	T _J = 25°C	T _J = 85°C	T _J = 105°C	T _J = 130°C	T _J = 140°C	
I _{DD(VBAT)}	Supply current in V _{BAT} mode	OFF	OFF	0.0	0.0	0.0	0.08	0.2	2.2	5.1	15.1	23.1	μA
		ON	OFF	1.2	1.3	1.4	1.46	2.5	11.7	20.4	46.0	61.5	
		OFF	ON	0.3	0.3	0.4	0.45	1.2	3.4	6.4	17.1	25.3	
		ON	ON	1.4	1.5	1.7	1.8	3.50	12.9	21.7	48.0	63.7	

1. Evaluated by characterization - Not tested in production.
2. LSE is in medium-low drive mode.

I/O system current consumption

All the I/Os used as inputs with pull-up generate a current consumption when the pin is externally held low. The value of this current consumption can be simply computed by using the pull-up/pull-down resistors values given in [Table 54](#).

To estimate the current consumption for the output pins, consider also external pull-downs or loads.

An additional I/O current consumption is due to I/Os configured as inputs if an intermediate voltage level is externally applied. This current consumption is caused by the Schmitt trigger circuits used to discriminate the input value. Unless this specific configuration is required by the application, this current consumption can be avoided by configuring the I/Os in analog mode. This is notably the case of ADC input pins, to be configured as analog inputs.

Caution: Any floating input pin can also settle to an intermediate voltage level or switch inadvertently, as a result of external electromagnetic noise. To avoid a current consumption related to floating pins, they must either be configured in analog mode, or forced internally to a definite digital value. This can be done by using pull-up/down resistors, or by configuring the pins in output mode.

In addition to the internal peripheral current consumption, the I/Os used by an application also contribute to the current consumption. When an I/O pin switches, it uses the current from the MCU supply voltage to supply the I/O pin circuitry and to charge/discharge the capacitive load (internal or external) connected to the pin:

$$I_{SW} = V_{DDx} \times f_{SW} \times C_L$$

where

I_{SW} is the current sunk by a switching I/O to charge/discharge the capacitive load

V_{DDx} is the MCU supply voltage

f_{SW} is the I/O switching frequency

C_L is the total capacitance seen by the I/O pin: C = C_{INT}+ C_{EXT} + C_S

The test pin is configured in push-pull output mode and is toggled by software at a fixed frequency.

Prerelease product(s)



On-chip peripheral current consumption

The MCU is placed under the following conditions:

- At startup, all I/O pins are in analog input configuration
- All peripherals are disabled unless otherwise mentioned
- The I/O compensation cell is enabled
- f_{HCLK} is the CPU clock, $f_{PCLK} = f_{rcc_cpu_ck}$, and $f_{HCLK} = f_{rcc_cpu_ck}$.

The given value is calculated by measuring the difference of current consumption:

- with all peripherals clocked off
- with only one peripheral clocked on
- $f_{rcc_cpu_ck} = 250$ MHz (Scale 0), $f_{rcc_cpu_ck} = 200$ MHz (Scale 1), $f_{rcc_cpu_ck} = 150$ MHz (Scale 2), $f_{rcc_cpu_ck} = 100$ MHz (Scale 3)
- the ambient operating temperature is 25°C and $V_{DD} = 3.0$ V

Table 34. Peripheral current consumption in Sleep mode

Bus	Peripheral	I _{DD} (typ)				Unit
		VOS0	VOS1	VOS2	VOS3	
AHB1	SRAM1	0.75	0.69	0.61	0.57	µA/MHz
	BKPRAM	0.52	0.51	0.43	0.40	
	GTZC1	1.20	1.05	0.96	0.89	
	DCACHE	0.65	0.61	0.52	0.50	
	ICACHE	0.78	0.72	0.64	0.60	
	ETHERNET MAC	18.50	16.50	15.00	13.50	
	RAMCFG	0.73	0.69	0.61	0.56	
	CORDIC	0.84	0.76	0.68	0.64	
	CRC	0.24	0.25	0.21	0.20	
	FLASH	17.00	14.50	13.50	12.00	
	GPDMA2	0.62	0.57	0.50	0.48	
GPDMA1	0.57	0.51	0.47	0.45		
APB2	SPI4	1.20	1.05	1.00	0.89	µA/MHz
	TIM15	2.10	1.80	1.65	1.50	
	USART1	1.40	1.25	1.15	1.00	
	TIM8	3.95	3.45	3.15	2.85	
	SPI1	1.25	1.10	1.00	0.92	
	USBFS	2.75	2.40	2.20	2.00	
	TIM1	4.50	3.95	3.65	3.30	

Prerelease product(s)

Table 34. Peripheral current consumption in Sleep mode

Bus	Peripheral	I _{DD} (typ)				Unit
		VOS0	VOS1	VOS2	VOS3	
APB1	UCPD1	1.25	1.05	0.98	0.89	μA/MHz
	FDCAN2	7.15	6.30	5.75	5.25	
	FDCAN1	7.15	6.30	5.75	5.25	
	LPTIM2	0.92	0.79	0.72	0.67	
	DTS	1.60	1.35	1.25	1.15	
	UART8	1.30	1.15	1.00	0.91	
	UART7	1.35	1.15	1.05	0.94	
	CEC	0.25	0.18	0.14	0.17	
	USART6	1.35	1.15	1.05	0.95	
	CRS	0.28	0.19	0.19	0.16	
	I3C1	0.55	0.46	0.40	0.36	
	I2C2	0.75	0.62	0.57	0.50	
	I2C1	0.72	0.62	0.56	0.50	
	UART5	1.35	1.15	1.05	0.97	
	UART4	1.35	1.20	1.10	1.00	
	USART3	2.00	1.75	1.60	1.45	
	USART2	1.65	1.40	1.25	1.20	
	COMP1/COMP2	0.29	0.22	0.19	0.20	
	SPI2	1.30	1.05	1.00	0.92	
	SPI3	1.20	1.05	0.95	0.89	
	IWDG	0.19	0.13	0.13	0.11	
	WWDG	0.19	0.13	0.13	0.11	
	TIM12	1.35	1.15	1.05	1.00	
	TIM7	0.60	0.54	0.48	0.44	
TIM6	0.60	0.52	0.47	0.44		
TIM5	2.75	2.40	2.15	2.00		
TIM4	2.30	2.00	1.80	1.65		
TIM3	2.35	2.05	1.85	1.70		
TIM2	3.30	2.90	2.65	2.45		

Prerelease product(s)

Table 34. Peripheral current consumption in Sleep mode

Bus	Peripheral	I _{DD} (typ)				Unit
		VOS0	VOS1	VOS2	VOS3	
AHB2	PKA+RAM	6.60	5.80	5.35	4.85	μA/MHz
	RNG	2.05	1.80	1.65	1.50	
	HASH	1.50	1.35	1.20	1.10	
	ADC3	1.15	1.00	0.92	0.85	
	DAC1	1.50	1.35	1.25	1.10	
	ADC1/ADC2	2.70	2.35	2.20	1.95	
	GPIOH	0.03	0.03	0.04	0.02	
	GPIOG	0.16	0.12	0.13	0.10	
	GPIOF	0.18	0.16	0.16	0.13	
	GPIOE	0.17	0.13	0.13	0.10	
	GPIOD	0.14	0.13	0.12	0.10	
	GPIOC	0.12	0.10	0.11	0.08	
	GPIOB	0.14	0.10	0.10	0.08	
	GPIOA	0.15	0.12	0.11	0.11	
	SRAM2	1.05	0.94	0.90	0.79	
	SRAM3	0.81	0.69	0.67	0.59	
USBFS	3.60	3.15	2.90	2.60		
APB3	PLAY	1.85	1.65	1.50	1.35	μA/MHz
	RTC	4.10	3.60	3.30	3.00	
	VREFBUF	0.07	0.09	0.06	0.04	
	LPTIM1	1.05	0.96	0.87	0.78	
	I3C2	0.54	0.50	0.45	0.39	
	I2C3	0.76	0.70	0.63	0.55	
	LPUART1	1.00	0.90	0.82	0.73	
	SBS	1.35	1.15	1.00	0.91	
AHB4	OCTOSPI1	1.00	0.86	0.83	0.76	μA/MHz
	FMC	12.50	11.00	10.00	9.10	
	SDMMC1	7.75	6.85	6.25	5.70	
	OTFDEC1	0.87	0.76	0.69	0.63	

Prerelease product(s)

Wake-up time from low-power modes

The times given in [Table 35](#) are measured starting from the wake-up event trigger up to the first instruction executed by the CPU:

- for Stop or Sleep modes: the wake-up event is WFE.
- WKUP (PA0) pin is used to wake-up from Standby, Stop, and Sleep modes.

All timings are derived from tests performed under ambient temperature and $V_{DD} = 3.0\text{ V}$.

Table 35. Low-power mode wake-up timings⁽¹⁾

Symbol	Parameter	Conditions	Typ	Max	Unit
$t_{WUSLEEP}$	Wake-up time from Sleep mode	Instruction cache enabled	TBD ⁽²⁾	TBD	CPU clock cycles
		Instruction cache disabled	TBD	TBD	
t_{WUSTOP}	Wake-up time from Stop mode	SVOS3, HSI 64 MHz, flash memory in normal mode	TBD	TBD	μs
		SVOS3, HSI 64 MHz, flash memory in low-power mode	TBD	TBD	
		SVOS4, HSI 64 MHz, flash memory in normal mode	TBD	TBD	
		SVOS4, HSI 64 MHz, flash memory in low-power mode	TBD	TBD	
		SVOS5, HSI 64 MHz, flash memory in low-power mode	TBD	TBD	
		SVOS3, CSI 4 MHz, flash memory in normal mode	TBD	TBD	
		SVOS3, CSI 4 MHz, flash memory in low power mode	TBD	TBD	
		SVOS4, CSI 4 MHz, flash memory in normal mode	TBD	TBD	
		SVOS4, CSI 4 MHz, flash memory in low-power mode	TBD	TBD	
		SVOS5, CSI 4 MHz, flash memory in low-power mode	TBD	TBD	
t_{WUSTBY}	Wake-up time from Standby mode	VCAP capacitors discharged	TBD	TBD	

1. Evaluated by characterization - Not tested in production.

2. TBD stands for to be defined.

5.3.7 External clock source characteristics

High-speed external user clock generated from an external source

In bypass mode the HSE oscillator is switched off and the input pin is a standard GPIO.

The external clock signal must respect the [Table 36](#) in addition to [Table 54](#). The external clock can be low-swing (analog) or digital. In case of a low-swing analog input clock, the clock squarer must be activated (refer to RM0481).

Table 36. High-speed external user clock characteristics⁽¹⁾

Symbol	Parameter	Conditions	Min	Typ	Max	Unit
f_{HSE_ext}	User external clock source frequency	External digital/analog clock	4	25	50	MHz

Prerelease product(s)

Table 36. High-speed external user clock characteristics⁽¹⁾ (continued)

Symbol	Parameter	Conditions	Min	Typ	Max	Unit
V_{HSEH}	Digital OSC_IN input high-level voltage	External digital clock	$0.7 V_{DD}$	-	V_{DD}	V
V_{HSEL}	Digital OSC_IN input low-level voltage		V_{SS}	-	$0.3 V_{DD}$	
$t_{w(HSEH)} / t_{w(HSEL)}$ ⁽²⁾	Digital OSC_IN input high or low time	External digital clock	7	-	-	ns
$V_{isw(HSEH)}$ $(V_{HSEH} - V_{HSEL})$ ⁽³⁾	Analog low-swing OSC_IN peak-to-peak amplitude	External analog low swing clock	0.2	-	$2/3 V_{DD}$	V
$DuCy_{HSE}$	Analog low-swing OSC_IN duty cycle		45	50	55	
$t_{r(HSE)} / t_{f(HSE)}$	Analog low-swing OSC_IN rise and fall times	External analog low swing clock, 10% to 90%	$0.05 / f_{HSE_ext}$	-	$0.3 / f_{HSE_ext}$	ns

1. Specified by design - Not tested in production..
2. The rise and fall times for a digital input signal are not specified, but the V_{HSEH} and V_{HSEL} conditions must be fulfilled anyway.
3. The DC component of the signal must ensure that the signal peaks are located between V_{DD} and V_{SS} .

Figure 19. High-speed external clock source AC timing diagram

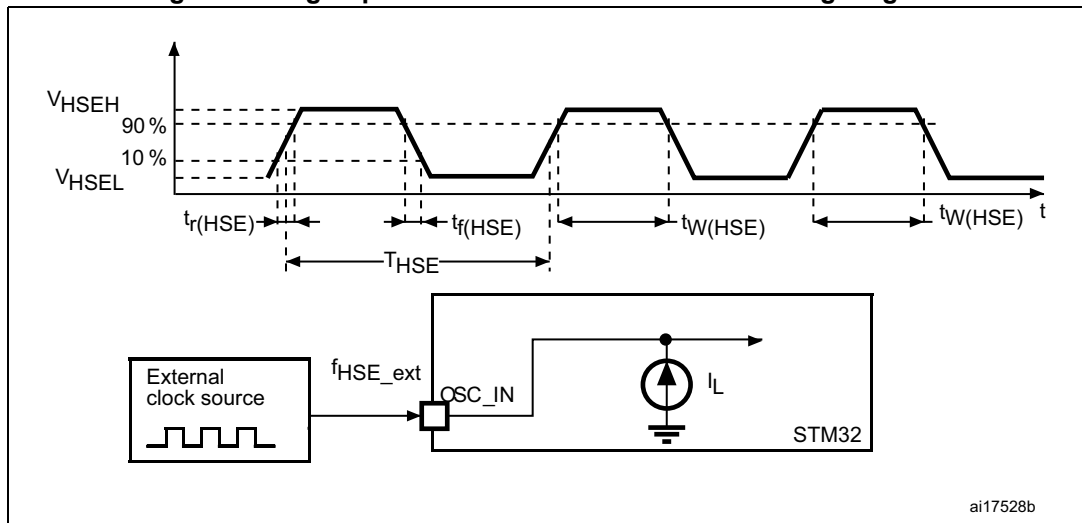

Low-speed external user clock generated from an external source

In bypass mode the LSE oscillator is switched off and the input pin is a standard GPIO.

The external clock signal must respect the [Table 37](#) in addition to [Table 54](#). The external clock must be low-swing (analog) or digital. In case of a low-swing analog input clock, the clock squarer must be activated (refer to RM0481).

Prerelease product(s)

Table 37. Low-speed external user clock characteristics⁽¹⁾

Symbol	Parameter	Conditions	Min	Typ	Max	Unit
f_{LSE_ext}	User external clock source frequency	External digital/analog clock	-	32.768	1000	kHz
V_{LSEH}	Digital OSC32_IN input high-level voltage	External digital clock	$0.7 V_{DD}$	-	V_{DD}	V
V_{LSEL}	Digital OSC32_IN input low-level voltage		V_{SS}	-	$0.3 V_{DD}$	
$t_{w(LSEH)}/t_{w(LSEL)}$	Digital OSC_IN input high or low time	External digital clock	250	-	-	ns

1. Specified by design - Not tested in production.

Note: For information on selecting the crystal, refer to AN2867 "Guidelines for oscillator design on STM8AF/AL/S and STM32 MCUs/MPUs" available from www.st.com.

Figure 20. Low-speed external clock source AC timing diagram

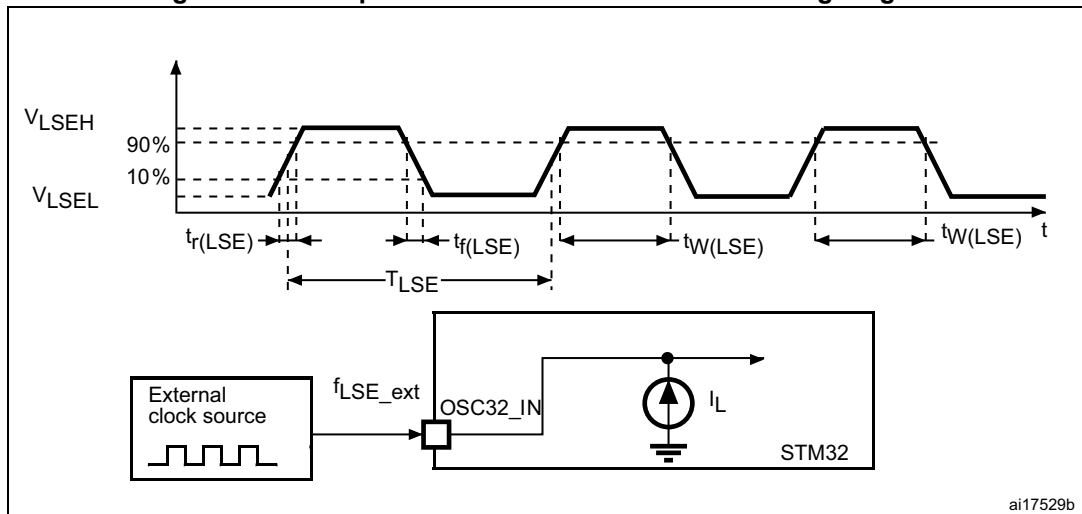

High-speed external clock generated from a crystal/ceramic resonator

The high-speed external (HSE) clock can be supplied with a 4 to 50 MHz crystal/ceramic resonator oscillator.

All the information given in this paragraph are based on characterization results obtained with typical external components specified in Table 38. In the application, the resonator and the load capacitors must be placed as close as possible to the oscillator pins to minimize output distortion and startup stabilization time. Refer to the crystal resonator manufacturer for more details on the resonator characteristics (frequency, package, accuracy).

Table 38. 4 to 50 MHz HSE oscillator characteristics⁽¹⁾

Symbol	Parameter	Operating conditions ⁽²⁾	Min	Typ	Max	Unit
F	Oscillator frequency	-	4	-	50	MHz
R_F	Feedback resistor	-	-	200	-	k Ω

Prerelease product(s)

Table 38. 4 to 50 MHz HSE oscillator characteristics⁽¹⁾ (continued)

Symbol	Parameter	Operating conditions ⁽²⁾	Min	Typ	Max	Unit
I _{DD(HSE)}	HSE current consumption	During startup ⁽³⁾	-	-	10	mA
		V _{DD} = 3 V, R _m = 20 Ω, C _L = 10 pF at 4 MHz	-	0.44	-	
		V _{DD} = 3 V, R _m = 20 Ω, C _L = 10 pF at 8 MHz	-	0.44	-	
		V _{DD} = 3 V, R _m = 20 Ω, C _L = 10 pF at 16 MHz	-	0.55	-	
		V _{DD} = 3 V, R _m = 20 Ω, C _L = 10 pF at 32 MHz	-	0.67	-	
		V _{DD} = 3 V, R _m = 20 Ω, C _L = 10 pF at 48 MHz	-	1.17	-	
G _{m_{critmax}}	Maximum critical crystal gm	Startup	-	-	1.5	mA/V
t _{SU(HSE)} ⁽⁴⁾	Startup time	V _{DD} is stabilized	-	2	-	ms

1. Evaluated by design - Not tested in production.
2. Resonator characteristics given by the crystal/ceramic resonator manufacturer.
3. This consumption level occurs during the first 2/3 of the t_{SU(HSE)} startup time
4. t_{SU(HSE)} is the startup time measured from the moment it is enabled (by software) to a stabilized 8 MHz oscillation is reached. This value is measured for a standard crystal resonator, it can vary significantly with the crystal manufacturer

Note: For information on selecting the crystal, refer to AN2867 “Guidelines for oscillator design on STM8AF/AL/S and STM32 MCUs/MPUs”, available from www.st.com.

Figure 21. Typical application with an 8 MHz crystal

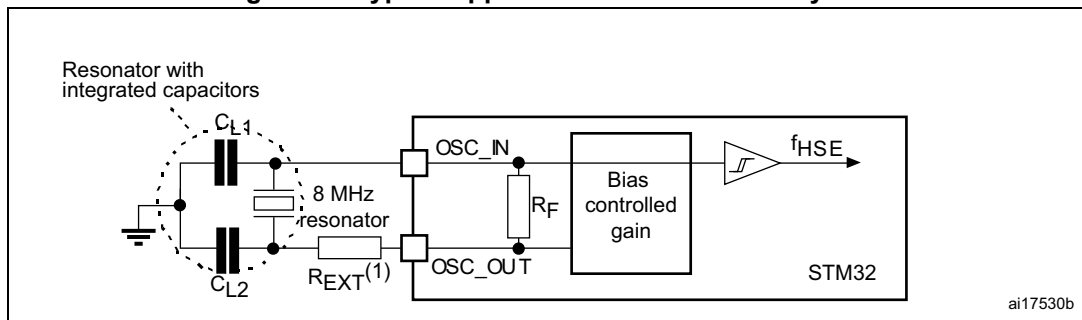

1. R_{EXT} value depends on the crystal characteristics.

Low-speed external clock generated from a crystal resonator

The low-speed external (LSE) clock can be supplied with a 32.768 kHz crystal resonator oscillator. All the information given in this paragraph is based on design simulation results obtained with typical external components specified in Table 39. In the application, the resonator and the load capacitors must be placed as close as possible to the oscillator pins to minimize output distortion and startup stabilization time. Refer to the crystal resonator manufacturer for more details on the resonator characteristics (frequency, package, accuracy).

Table 39. Low-speed external user clock characteristics⁽¹⁾

Symbol	Parameter	Conditions ⁽²⁾	Min	Typ	Max	Unit
F	Oscillator frequency	-	-	32.768	-	kHz
I _{DD}	LSE current consumption	LSEDRV[1:0] = 00 Low drive capability	-	246	-	nA
		LSEDRV[1:0] = 01 Medium low drive capability	-	333	-	
		LSEDRV[1:0] = 10 Medium high drive capability	-	462	-	
		LSEDRV[1:0] = 11 High drive capability	-	747	-	
G _m _{critmax}	Maximum critical crystal gm	LSEDRV[1:0] = 00 Low drive capability	-	-	0.5	μA/V
		LSEDRV[1:0] = 01 Medium low drive capability	-	-	0.75	
		LSEDRV[1:0] = 10 Medium high drive capability	-	-	1.7	
		LSEDRV[1:0] = 11 High drive capability	-	-	2.7	
t _{SU(LSE)} ⁽³⁾	Startup time	V _{DD} is stabilized	-	2	-	s

1. Specified by design - Not tested in production.
2. Refer to the note and caution paragraphs below the table, and to AN2867 "Guidelines for oscillator design on STM8AF/AL/S and STM32 MCUs/MPUs".
3. t_{SU(LSE)} is the startup time measured from the moment it is enabled (by software) to when a stabilized 32.768 kHz oscillation is reached. This value is measured for a standard crystal, it can vary significantly with the crystal manufacturer

Note: For information on selecting the crystal, refer to AN2867 "Guidelines for oscillator design on STM8AF/AL/S and STM32 MCUs/MPUs", available from www.st.com.

Figure 22. Typical application with a 32.768 kHz crystal

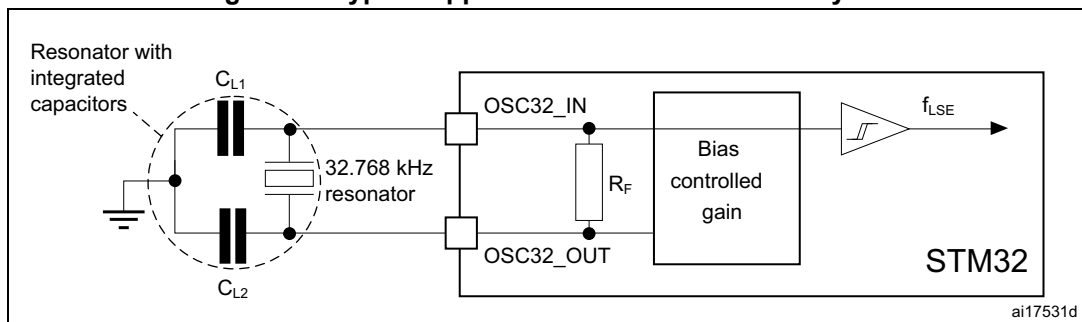

Note: An external resistor is not required between OSC32_IN and OSC32_OUT, and it is forbidden to add one.

Prerelease product(s)

5.3.8 Internal clock source characteristics

The parameters given in [Table 40](#) to [Table 43](#) are derived from tests performed under ambient temperature and V_{DD} supply voltage conditions summarized in [Table 17](#).

48 MHz high-speed internal RC oscillator (HSI48)

Table 40. HSI48 oscillator characteristics

Symbol	Parameter	Conditions	Min	Typ	Max	Unit
f_{HSI48}	HSI48 frequency	$V_{DD} = 3.3 \text{ V}$, $T_J = 30^\circ\text{C}$	47.5 ⁽¹⁾	48	48.5 ⁽¹⁾	MHz
TRIM ⁽³⁾	User trimming step	-	-	0.175	0.250	%
USER TRIM COVERAGE ⁽²⁾	User trimming coverage	± 32 steps	± 4.70	± 5.6	-	
DuCy(HSI48) ⁽³⁾	Duty cycle	-	45	-	55	%
ACC_HSI48_REL ⁽³⁾	Accuracy of the HSI48 oscillator over temperature (reference is 30°C)	$T_J = -40$ to 140°C	-4.5	-	4	%
$\Delta_{V_{DD}}(\text{HSI48})$	HSI48 oscillator frequency drift with V_{DD} (reference is 3.3 V)	$V_{DD} = 3.0$ to 3.6 V	-	0.025	0.05	%
		$V_{DD} = 1.71$ to 3.6 V	-	0.05	0.1	
$t_{\text{su}}(\text{HSI48})$ ⁽³⁾	HSI48 oscillator start-up time	-	-	2.1	4.0	μs
$I_{DD}(\text{HSI48})$ ⁽³⁾	HSI48 oscillator power consumption	-	-	350	400	μA
N_T jitter ⁽³⁾	Next transition jitter accumulated jitter on 28 cycles	-	-	± 0.15	-	ns
P_T jitter ⁽³⁾	Paired transition jitter accumulated jitter on 56 cycles ⁽⁴⁾	-	-	± 0.25	-	

1. Calibrated during manufacturing tests.
2. Evaluated by characterization - Not tested in production.
3. Specified by design - Not tested in production.
4. Jitter measurements are performed without clock sources activated in parallel.

64 MHz high-speed internal RC oscillator (HSI)

Table 41. HSI oscillator characteristics⁽¹⁾

Symbol	Parameter	Conditions	Min	Typ	Max	Unit
f_{HSI}	Frequency	$V_{DD} = 3.3 \text{ V}$, $T_J = 30^\circ\text{C}$	63.7 ⁽²⁾	64.0 ⁽²⁾	64.3 ⁽²⁾	MHz
TRIM	User trimming step	Trimming is not a multiple of 32 ⁽³⁾	-	0.24	0.32	%
		Trimming is 128, 256, and 384 ⁽³⁾	-5.2	-1.8	-	
		Trimming is 64, 192, 320, and 488 ⁽³⁾	-1.4	-0.8	-	
		Other trimmings are multiples of 32 (not including multiples of 64 and 128) ⁽³⁾	-0.6	-0.25	-	
DuCy(HSI)	Duty cycle	-	45	-	55	%

Table 41. HSI oscillator characteristics⁽¹⁾ (continued)

Symbol	Parameter	Conditions	Min	Typ	Max	Unit
$\Delta_{VDD}(HSI)$	Frequency drift with V_{DD} (reference is 3.3 V)	$V_{DD}= 1.71$ to 3.6 V	-0.12	-	0.03	%
$\Delta_{TEMP}(HSI)$	Frequency drift with V_{DD} (reference is 64 MHz)	$T_J= -20$ to $105^{\circ}C$	-1 ⁽⁴⁾	-	1 ⁽⁴⁾	
		$T_J= -40$ to $140^{\circ}C$	-2 ⁽⁴⁾	-	1 ⁽⁴⁾	
$t_{su}(HSI)$	Start-up time	-	-	1.4	2.0	μs
$t_{stab}(HSI)$	Stabilization time	At 1% of target frequency	-	4	8	μs
		At 5% of target frequency	-	-	4	
$I_{DD}(HSI)$	Power consumption	-	-	300	450	μA

1. Specified by design - Not tested in production, unless otherwise specified.
2. Calibrated during manufacturing tests.
3. Trimming value of HSICAL[8:0].
4. Guaranteed by characterization - Not tested in production.

4 MHz low-power internal RC oscillator (CSI)

Table 42. CSI oscillator characteristics⁽¹⁾

Symbol	Parameter	Conditions	Min	Typ	Max	Unit
f_{CSI}	Frequency	$V_{DD} = 3.3$ V, $T_J = 30^{\circ}C$	3.96 ⁽²⁾	4	4.04 ⁽²⁾	MHz
TRIM	User trimming step	Trimming is not a multiple of 16	-	0.40	0.75	%
		Trimming is not a multiple of 32	-4.75	-2.75	0.75	
		Other trimmings are a multiple of 32 (not including multiples of 64 and 128)	-0.43	0.00	0.75	
DuCy(CSI)	Duty cycle	-	45	-	55	%
$\Delta_{TEMP}(CSI)$	Frequency drift over temperature	$T_J= 0$ to $85^{\circ}C$	-3.7 ⁽³⁾	-	4.5 ⁽³⁾	%
		$T_J= -40$ to $T_J = 140^{\circ}C$	-11 ⁽³⁾	-	7.5 ⁽³⁾	%
$\Delta_{VDD}(CSI)$	Frequency drift over V_{DD}	$V_{DD}= 1.71$ to 3.6 V	-0.06	-	0.06	%
$t_{su}(CSI)$	Start-up time	-	-	1	2	μs
$t_{stab}(CSI)$	Stabilization time (to reach $\pm 3\%$ of f_{CSI})	-	-	-	4	cycle
$I_{DD}(CSI)$	Power consumption	-	-	23	30	μA

1. Specified by design - Not tested in production, unless otherwise specified.
2. Calibrated during manufacturing tests.
3. Evaluated by characterization - Not tested in production.

Prerelease product(s)



Low-speed internal (LSI) RC oscillator

Table 43. LSI oscillator characteristics

Symbol	Parameter	Conditions	Min	Typ	Max	Unit
f_{LSI}	Frequency	$V_{DD} = 3.3\text{ V}$, $T_J = 25^\circ\text{C}$	31.4 ⁽¹⁾	32	32.6 ⁽¹⁾	kHz
		$T_J = -40\text{ to }110^\circ\text{C}$, $V_{DD} = 1.71\text{ to }3.6\text{ V}$	29.76 ⁽²⁾	-	33.6 ⁽²⁾	
		$T_J = -40\text{ to }140^\circ\text{C}$, $V_{DD} = 1.71\text{ to }3.6\text{ V}$	29.4 ⁽²⁾	-	33.6 ⁽²⁾	
$t_{su}(LSI)^{(3)}$	Start-up time	-	-	80	130	μs
$t_{stab}(LSI)^{(3)}$	Stabilization time (5% of final value)	-	-	120	170	
$I_{DD}(LSI)^{(3)}$	Power consumption	-	-	130	280	nA

1. Calibrated during manufacturing tests.
2. Evaluated by characterization - Not tested in production.
3. Specified by design - Not tested in production.

5.3.9 PLL characteristics

The parameters given in [Table 44](#) are derived from tests performed under temperature and V_{DD} supply voltage conditions summarized in [Table 17](#).

Table 44. PLL characteristics (wide VCO frequency range)⁽¹⁾

Symbol	Parameter	Conditions	Min	Typ	Max	Unit
f_{PLL_IN}	PLL input clock	-	2	-	16	MHz
	PLL input clock duty cycle	-	10	-	90	%
$f_{PLL_P_OUT}$	PLL multiplier output clock P, Q, R	VOS0	1	-	250 ⁽²⁾	MHz
		VOS1	1	-	200 ⁽²⁾	
		VOS2	1	-	150 ⁽²⁾	
		VOS3	1	-	100 ⁽²⁾	
f_{VCO_OUT}	PLL VCO output	-	128	-	560 ⁽²⁾	
t_{LOCK}	PLL lock time	Normal mode	-	45	100 ⁽³⁾	μs
		Sigma-delta mode ($f_{PLL_IN} \geq 8\text{ MHz}$)	-	60	120 ⁽³⁾	

Table 44. PLL characteristics (wide VCO frequency range)⁽¹⁾ (continued)

Symbol	Parameter	Conditions	Min	Typ	Max	Unit	
Jitter	Cycle-to-cycle jitter	$f_{VCO_OUT} = 128$ MHz	-	60	-	±ps	
		$f_{VCO_OUT} = 200$ MHz	-	50	-		
		$f_{VCO_OUT} = 400$ MHz	-	20	-		
		$f_{VCO_OUT} = 560$ MHz	-	15	-		
	Long term jitter ⁽⁴⁾	Normal mode ($f_{PLL_IN} = 2$ MHz), $f_{VCO_OUT} = 560$ MHz	-	±0.2	-	%	
		Normal mode ($f_{PLL_IN} = 16$ MHz), $f_{VCO_OUT} = 560$ MHz	-	±0.8	-		
		Sigma-delta mode ($f_{PLL_IN} = 2$ MHz), $f_{VCO_OUT} = 560$ MHz	-	±0.2	-		
		Sigma-delta mode ($f_{PLL_IN} = 16$ MHz), $f_{VCO_OUT} = 560$ MHz	-	±0.8	-		
$I_{DD(PLL)}$	PLL power consumption on V_{DD}	$f_{VCO_OUT} = 560$ MHz	V_{DD}	-	330	420	µA
			V_{CORE}	-	630	-	
		$f_{VCO_OUT} = 128$ MHz	V_{DD}	-	155	230	
			V_{CORE}	-	170	-	

1. Specified by design - Not tested in production, unless otherwise specified.
2. This value must be limited to the maximum frequency due to the product limitation.
3. Evaluated by characterization - Not tested in production.
4. Given as percentage of the input clock period.

Table 45. PLL characteristics (medium VCO frequency range)

Symbol	Parameter	Conditions	Min ⁽¹⁾	Typ ⁽¹⁾	Max ⁽¹⁾	Unit
f_{PLL_IN}	PLL input clock	-	1	-	2	MHz
	PLL input clock duty cycle	-	10	-	90	%
f_{PLL_OUT}	PLL multiplier output clock P, Q, R	VOS0	1.17	-	210	MHz
		VOS1	1.17	-	210	
		VOS2	1.17	-	160 ⁽²⁾	
		VOS3	1.17	-	88 ⁽²⁾	
f_{VCO_OUT}	PLL VCO output	-	150	-	420	
t_{LOCK}	PLL lock time	Normal mode	-	45	80 ⁽³⁾	µs
		Sigma-delta mode	Forbidden			

Table 45. PLL characteristics (medium VCO frequency range) (continued)

Symbol	Parameter	Conditions		Min ⁽¹⁾	Typ ⁽¹⁾	Max ⁽¹⁾	Unit
Jitter	Cycle-to-cycle jitter	$f_{VCO_OUT} = 150 \text{ MHz}$	-	-	60	-	±ps
		$f_{VCO_OUT} = 200 \text{ MHz}$	-	-	40	-	
		$f_{VCO_OUT} = 400 \text{ MHz}$	-	-	18	-	
		$f_{VCO_OUT} = 420 \text{ MHz}$	-	-	15	-	
	Period jitter	$f_{VCO_OUT} = 150 \text{ MHz}$	$f_{PLL_OUT} = 50 \text{ MHz}$	-	75	-	
		$f_{VCO_OUT} = 400 \text{ MHz}$		-	25	-	
	Long term jitter ⁽⁴⁾	Normal mode $f_{VCO_OUT} = 400 \text{ MHz}$		-	±0.2	-	%
$I_{DD(PLL)}$	PLL power consumption on V_{DD}	$f_{VCO_OUT} = 420 \text{ MHz}$	V_{DD}	-	275	360	µA
			V_{CORE}	-	450	-	
		$f_{VCO_OUT} = 150 \text{ MHz}$	V_{DD}	-	160	240	
			V_{CORE}	-	165	-	

1. Specified by design - Not tested in production, unless otherwise specified.
2. This value must be limited to the maximum frequency due to the product limitation.
3. Evaluated by characterization - Not tested in production.
4. Given as percentage of the input clock period.

5.3.10 Memory characteristics

Flash memory

The characteristics are given at $T_j = -40$ to 140°C unless otherwise specified.

The devices are shipped to customers with the flash memory erased.

Table 46. Flash memory characteristics

Symbol	Parameter	Conditions	Min	Typ	Max ⁽¹⁾	Unit
I_{DD}	Supply current	Word program ⁽²⁾	-	2.5	3.6	mA
		Sector erase	-	1.8	4	
		Mass erase	-	2.0	4	

1. Specified by design - Not tested in production
2. Data are evaluated with a write of 50% of the programmed bits equal to 0.

Table 47. Flash memory programming⁽¹⁾

Symbol	Parameter	Conditions	Min ⁽²⁾	Typ	Max ⁽¹⁾	Unit
t_{prog}	Word program time	128 bits (user area)	-	30	240	µs
		16 bits (OTP area)	-	30	240	
t_{ERASE}	Sector erase time (8 Kbytes)		-	2	10	ms

Table 47. Flash memory programming⁽¹⁾ (continued)

Symbol	Parameter	Conditions	Min ⁽²⁾	Typ	Max ⁽¹⁾	Unit
t _{ME}	Mass erase time	-	-	256	1280	ms
t _{BE}	Bank erase time	-	-	128	640	
V _{prog}	Programming voltage		1.71	3	3.6	V

1. Data are valid for program memory and high-cycling data memory.
2. Specified by design - Not tested in production.

Table 48. Flash memory endurance and data retention

Symbol	Parameter	Conditions	Min ⁽¹⁾	Unit
N _{PEND}	Endurance program memory	T _J = -40 to +140°C	10	kcycles
N _{DEND}	Endurance data memory	T _J = -40 to +140°C	100	
t _{PRET}	Program memory, data retention	1 kcycle at T _A = 125°C	10	Years
		1 kcycles at T _A = 85°C	30	
		10 kcycles at T _A = 55°C	30	
t _{DRET}	Data retention for data memory	100 kcycle at T _A = 125°C	1	
		100 kcycles at T _A = 85°C	10	
		100 kcycles at T _A = 55°C	10	

1. Evaluated by characterization - Not tested in production, unless otherwise specified.

5.3.11 EMC characteristics

Susceptibility tests are performed on a sample basis during device characterization.

Functional EMS (electromagnetic susceptibility)

While a simple application is executed (toggling two LEDs through I/O ports), the device is stressed by two electromagnetic events until a failure occurs. The failure is indicated by the LEDs:

- **Electrostatic discharge (ESD)**, positive and negative, is applied to all device pins until a functional disturbance occurs. This test is compliant with the IEC 61000-4-2 standard.
- **FTB**: A burst of fast transient voltage (positive and negative) is applied to V_{DD} and V_{SS} through a 100 pF capacitor, until a functional disturbance occurs. This test is compliant with the IEC 61000-4-4 standard.

A device reset allows to resume normal operation.

The test results are given in [Table 49](#). They are based on the EMS levels and classes defined in AN1709 “EMC design guide for STM8, STM32 and legacy MCUs”.

Table 49. EMS characteristics

Symbol	Parameter	Conditions	Level/Class
V_{FESD}	Voltage limits to apply on any I/O pin to induce a functional disturbance	$V_{DD} = 3.3\text{ V}$, $T_A = 25^\circ\text{C}$, LQFP144, $f_{rcc_cpu_ck} = 250\text{ MHz}$, conform to IEC 61000-4-2	2B
V_{FTB}	Fast transient voltage burst limits to apply through 100 pF on VDD and VSS pins to induce a functional disturbance		5A

As a consequence, it is recommended to add a serial resistor (1 k Ω), located as close as possible to the MCU, to the pins exposed to noise (connected to tracks longer than 50 mm on PCB).

Designing hardened software to avoid noise problems

EMC characterization and optimization are performed at component level with a typical application environment and simplified MCU software. Good EMC performance is highly dependent upon the user application, and the software in particular.

Therefore it is recommended that the user applies EMC software optimization and prequalification tests in relation with the EMC level requested for its application.

Software recommendations

The software flow must include the management of runaway conditions such as:

- Corrupted program counter
- Unexpected reset
- Critical data corruption (such as control registers)

Prequalification trials

Most of the common failures (unexpected reset and program counter corruption) can be reproduced by manually forcing a low state on the NRST or on the oscillator pins for 1 s.

To complete these trials, ESD stress can be applied directly on the device, over the range of specification values. When unexpected behavior is detected, the software can be hardened to prevent unrecoverable errors occurring (see application note AN1015 “*Software techniques for improving microcontrollers EMC performance*”).

Electromagnetic interference (EMI)

The electromagnetic field emitted by the device is monitored while a simple application, executing EEMBC code, is running. This emission test is compliant with SAE IEC61967-2 standard, which specifies the test board and the pin loading.

Table 50. EMI characteristics

Symbol	Parameter	Conditions	Monitored frequency band	Max vs. [f _{HSE} /f _{CPU}]	Unit
				25/250 MHz	
S _{EMI}	Peak level ⁽¹⁾	V _{DD} = 3.6 V, T _A = 25°C, LQFP144 package, conforming to IEC61967-2	0.1 to 30 MHz	12	dBμV
			30 to 130 MHz	15	
			130 MHz to 1 GHz	29	
			1 GHz to 2 GHz	21	
			EMI level	3.5	-

1. Refer to the EMI radiated test chapter of application note AN1709 “EMC design guide for STM8, STM32 and legacy MCUs” available from the ST website www.st.com.

5.3.12 Absolute maximum ratings (electrical sensitivity)

Based on three different tests (ESD, LU) using specific measurement methods, the device is stressed to determine its performance in terms of electrical sensitivity.

Electrostatic discharge (ESD)

Electrostatic discharges (a positive pulse followed by a negative one) are applied to the pins of each sample according to each pin combination. This test conforms to the ANSI/ESDA/JEDEC JS-001 and ANSI/ESDA/JEDEC JS-002 standards.

Table 51. ESD absolute maximum ratings

Symbol	Ratings	Conditions	Packages	Class	Maximum value ⁽¹⁾	Unit
V _{ESD(HBM)}	Electrostatic discharge voltage (human body model)	T _A = 25°C, conforming to ANSI/ESDA/JEDEC JS-001	All packages	2	2000	V
V _{ESD(CDM)}	Electrostatic discharge voltage (charge device model)	T _A = 25°C, conforming to ANSI/ESDA/JEDEC JS-002	UFBGA144	C3	1250	V
			LQFP144	C2	500	

1. Evaluated by characterization - Not tested in production.

Static latch-up

Two complementary static tests are required on six parts to assess the latch-up performance:

- A supply overvoltage is applied to each power supply pin
- A current injection is applied to each input, output, and configurable I/O pin

These tests are compliant with the JESD78 IC latch-up standard.

Table 52. Electrical sensitivities

Symbol	Parameter	Conditions	Class
LU	Static latch-up class	T _J = 140°C, conforming to JESD78	II level A

Prerelease product(s)

5.3.13 I/O current injection characteristics

As a general rule, avoid current injection to the I/O pins, due to external voltage below V_{SS} or above V_{DD} (for standard, 3.3 V-capable I/O pins) during the normal product operation. To give an indication of the device robustness when an abnormal injection accidentally happens, susceptibility tests are performed on a sample basis during the characterization.

Functional susceptibility to I/O current injection

While a simple application is executed, the device is stressed by injecting current into the I/O pins (one at the time) programmed in floating input mode, and checked for functional failures. The failure is indicated by an out of range parameter: ADC error above a certain limit (higher than 5 LSB TUE), out of conventional limits (-5 / +0 μ A range) of induced leakage current on adjacent pins, or other functional failures (such as reset, oscillator frequency deviation).

The following table shows I/Os current injection susceptibility data. Negative/positive induced leakage currents are caused, respectively, by negative/positive injection.

Table 53. I/O current injection susceptibility⁽¹⁾

Symbol	Description	Functional susceptibility		Unit
		Negative injection	Positive injection	
I_{INJ}	Injected current on pins PA4, PA5, PA11, and PA12	0	0	mA
	Injected current on pins PC14, PC15, BOOT0, NRESET, PA8, PB3, PB4, PB5, PB6, PB7, PB8, and also PG15, PB9, PE0	0	N/A	
	Injected current on all other pins	5	N/A	

1. Evaluated by characterization - Not tested in production.

5.3.14 I/O port characteristics

General input/output characteristics

Unless otherwise specified, the parameters given in [Table 54](#) are derived from tests performed under the conditions summarized in [Table 17](#). All I/Os are CMOS and TTL compliant (except for BOOT0).

Note: For information on GPIO configuration, refer to AN4899 “STM32 GPIO configuration for hardware settings and low-power consumption”, available on www.st.com.

Table 54. I/O static characteristics⁽¹⁾

Symbol	Parameter	Conditions	Min	Typ	Max	Unit
V_{IL}	I/O input low level voltage except BOOT0	$1.08\text{ V} < V_{DDIOx} < 3.6\text{ V}$	-	-	$0.3 V_{DDIOx}^{(2)}$	V
	I/O input low level voltage except BOOT0		-	-	$0.4 V_{DDIOx} - 0.1^{(3)}$	
	BOOT0 I/O input low level voltage		-	-	$0.19 V_{DDIOx} + 0.1^{(3)}$	

Table 54. I/O static characteristics⁽¹⁾ (continued)

Symbol	Parameter	Conditions	Min	Typ	Max	Unit
V _{IH}	I/O input high level voltage except BOOT0	1.08 V < V _{DDIOx} < 3.6 V	0.7 V _{DDIOx} ⁽²⁾	-	-	V
	I/O input high level voltage except BOOT0		0.52 V _{DDIOx} + 0.18 ⁽³⁾	-	-	
	BOOT0 I/O input high level voltage		0.17 V _{DDIOx} + 0.6 ⁽³⁾	-	-	
V _{HYS} ⁽³⁾	TT_xx, FT_XXX and NRST I/O input hysteresis	1.08 V < V _{DDIOx} < 3.6 V	-	250	-	mV
	BOOT0 I/O input hysteresis	1.71 V < V _{DDIOx} < 3.6 V	-	200	-	
I _{leak} ⁽⁴⁾	FT_xx input leakage current ⁽³⁾	0 < V _{IN} ≤ Max(V _{DDXXX}) ⁽⁷⁾	-	-	±200	nA
		Max(V _{DDXXX}) < V _{IN} ≤ Max(V _{DDXXX}) + 1 V ⁽⁵⁾⁽⁷⁾	-	-	2500	
		Max(V _{DDXXX}) < V _{IN} ≤ 5.5 V ⁽⁵⁾⁽⁷⁾	-	-	750	
	TT_xx input leakage current	0 < V _{IN} ≤ Max(V _{DDXXX}) ⁽⁷⁾	-	-	±200	
	BOOT0	0 < V _{IN} ≤ V _{DDIOx}	-	-	15	
R _{PU}	Weak pull-up equivalent resistor ⁽⁶⁾	V _{IN} = V _{SS}	30	40	50	kΩ
R _{PD}	Weak pull-down equivalent resistor ⁽⁶⁾	V _{IN} = V _{DD} ⁽⁷⁾	30	40	50	
C _{IO}	I/O pin capacitance	-	-	5	-	pF

- V_{DDIOx} represents V_{DD} or V_{DDIO2}.
- Compliant with CMOS requirements.
- Specified by design - Not tested in production.
- This parameter represents the pad leakage of the I/O itself. The total product pad leakage is provided by the following formula: I_{Total_leak_max} = 10 μA + [number of I/Os where V_{IN} is applied on the pad] × I_{Ikg(Max)}.
- V_{IN} must be lower than Max(V_{DDXXX}) + 3.6 V.
- The pull-up and pull-down resistors are designed with a true resistance in series with a switchable PMOS/NMOS. This PMOS/NMOS contribution to the series resistance is minimal (~10%).
- Max(V_{DDXXX}) is the maximum value of all the I/O supplies.

All I/Os are CMOS and TTL compliant (no software configuration required). Their characteristics cover more than the strict CMOS technology or TTL parameters. The coverage of these requirements for FT I/Os is shown in the following figure.

Prerelease product(s)

Figure 23. V_{IL}/V_{IH} for all I/Os except BOOT0

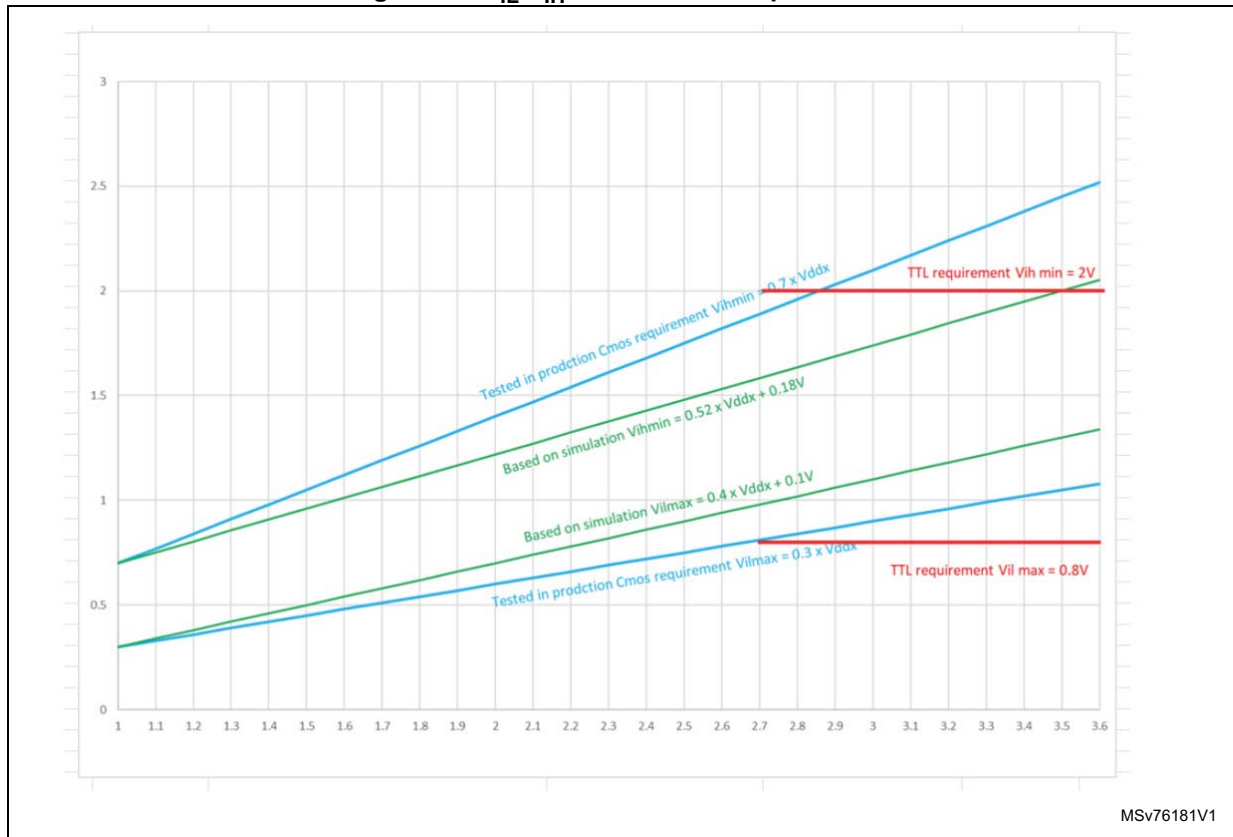

Output driving current

The GPIOs (general purpose input/outputs) can sink or source up to ± 8 mA, and sink or source up to ± 20 mA (with a relaxed V_{OL}/V_{OH}).

In the user application, the number of I/O pins that can drive current must be limited to respect the absolute maximum rating specified in [Section 5.2](#). In particular:

- The sum of the currents sourced by all the I/Os on V_{DD} , plus the maximum Run consumption of the MCU sourced on V_{DD} , cannot exceed the absolute maximum rating ΣI_{VDD} (see [Table 15](#)).
- The sum of the currents sunk by all the I/Os on V_{SS} plus the maximum Run consumption of the MCU sunk on V_{SS} cannot exceed the absolute maximum rating ΣI_{VSS} (see [Table 15](#)).

Output voltage levels

Unless otherwise specified, the parameters given in [Table 55](#) and [Table 57](#) are derived from tests performed under ambient temperature and V_{DD} supply voltage conditions summarized in [Table 17](#). All I/Os are CMOS and TTL compliant.

Prerelease product(s)

Table 55. Output voltage characteristics for all I/Os except PC13, PC14, and PC15

Symbol	Parameter	Conditions ⁽¹⁾	Min	Max	Unit
V _{OL}	Output low level voltage	CMOS port ⁽²⁾ , I _{IO} = 8 mA 2.7 V ≤ V _{DD} ≤ 3.6 V	-	0.4	V
V _{OH}	Output high level voltage	CMOS port ⁽²⁾ , I _{IO} = -8 mA 2.7 V ≤ V _{DD} ≤ 3.6 V	V _{DD} - 0.4	-	
V _{OL} ⁽³⁾	Output low level voltage	TTL port ⁽²⁾ , I _{IO} = 8 mA 2.7 V ≤ V _{DD} ≤ 3.6 V	-	0.4	
V _{OH} ⁽³⁾	Output high level voltage	TTL port ⁽²⁾ , I _{IO} = -8 mA 2.7 V ≤ V _{DD} ≤ 3.6 V	2.4	-	
V _{OL} ⁽³⁾	Output low level voltage	I _{IO} = 20 mA 2.7 V ≤ V _{DD} ≤ 3.6 V	-	1.3	
V _{OH} ⁽³⁾	Output high level voltage	I _{IO} = -20 mA 2.7 V ≤ V _{DD} ≤ 3.6 V	V _{DD} - 1.3	-	
V _{OL} ⁽³⁾	Output low level voltage	I _{IO} = 4 mA 1.71 V ≤ V _{DD} ≤ 3.6 V	-	0.4	
V _{OH} ⁽³⁾	Output high level voltage	I _{IO} = -4 mA 1.71 V ≤ V _{DD} < 3.6 V	V _{DD} - 0.4	-	
V _{OL} ⁽³⁾	Output low level voltage	I _{IO} = 2 mA 1.08 V ≤ V _{DD} ≤ 1.32 V	-	0.3 V _{DDIO2}	
V _{OH} ⁽³⁾	Output high level voltage	I _{IO} = -2 mA 1.71 V ≤ V _{DD} < 1.32 V	0.7 V _{DDIO2}	-	
V _{OLFM+} ⁽³⁾	Output low level voltage for an FTf I/O pin in (FT I/O with "f" option)	I _{IO} = 20 mA 2.3 V ≤ V _{DD} ≤ 3.6 V	-	0.4	
		I _{IO} = 10 mA 1.71 V ≤ V _{DD} ≤ 3.6 V	-	0.4	
		I _{IO} = 4.5 mA 1.08 V ≤ V _{DD} ≤ 3.6 V	-	0.4	

1. The I_{IO} current sourced or sunk by the device must always respect the absolute maximum rating specified in [Table 14](#), and the sum of the currents sourced or sunk by all the I/Os (I/O ports and control pins) must always respect the absolute maximum ratings ΣI_{IO}.
2. TTL and CMOS outputs are compatible with JEDEC standards JESD36 and JESD52.
3. Specified by design - Not tested in production.

Prerelease product(s)

Table 56. Output voltage characteristics for FT_c I/Os

Symbol	Parameter	Conditions ⁽¹⁾	Min	Max	Unit
V _{OL}	Output low level voltage	CMOS port ⁽²⁾ , I _{IO} = 2 mA 2.7 V ≤ V _{DD} ≤ 3.6 V	-	0.4	V
V _{OH}	Output high level voltage	CMOS port ⁽²⁾ , I _{IO} = -2 mA 2.7 V ≤ V _{DD} ≤ 3.6 V	V _{DD} - 0.4	-	
V _{OL} ⁽³⁾	Output low level voltage	TTL port ⁽²⁾ , I _{IO} = 2 mA 2.7 V ≤ V _{DD} ≤ 3.6 V	-	0.4	
V _{OH} ⁽³⁾	Output high level voltage	TTL port ⁽²⁾ , I _{IO} = -2 mA 2.7 V ≤ V _{DD} ≤ 3.6 V	2.4	-	
V _{OL} ⁽³⁾	Output low level voltage	I _{IO} = 1 mA 2.7 V ≤ V _{DD} ≤ 3.6 V	-	0.4	
V _{OH} ⁽³⁾	Output high level voltage	I _{IO} = -1 mA 2.7 V ≤ V _{DD} ≤ 3.6 V	V _{DD} - 0.4	-	
V _{OL} ⁽³⁾	Output low level voltage	I _{IO} = 0.1 mA 1.71 V ≤ V _{DD} ≤ 3.6 V	-	0.4	
V _{OH} ⁽³⁾	Output high level voltage	I _{IO} = -0.1 mA 1.71 V ≤ V _{DD} < 3.6 V	V _{DD} - 0.4	-	

1. The I_{IO} current sourced or sunk by the device must always respect the absolute maximum rating specified in [Table 14](#), and the sum of the currents sourced or sunk by all the I/Os (I/O ports and control pins) must always respect the absolute maximum ratings ΣI_{IO}.
2. TTL and CMOS outputs are compatible with JEDEC standards JESD36 and JESD52.
3. Specified by design - Not tested in production.

Table 57. Output voltage characteristics for PC13⁽¹⁾

Symbol	Parameter	Conditions ⁽³⁾	Min	Max	Unit
V _{OL}	Output low level voltage	CMOS port ⁽²⁾ , I _{IO} = 3 mA 2.7 V ≤ V _{DD} ≤ 3.6 V	-	0.4	V
V _{OH}	Output high level voltage	CMOS port ⁽²⁾ , I _{IO} = -3 mA 2.7 V ≤ V _{DD} ≤ 3.6 V	V _{DD} - 0.4	-	
V _{OL} ⁽³⁾	Output low level voltage	TTL port ⁽²⁾ , I _{IO} = 3 mA 2.7 V ≤ V _{DD} ≤ 3.6 V	-	0.4	
V _{OH} ⁽³⁾	Output high level voltage	TTL port ⁽²⁾ , I _{IO} = -3 mA 2.7 V ≤ V _{DD} ≤ 3.6 V	2.4	-	
V _{OL} ⁽³⁾	Output low level voltage	I _{IO} = 1.5 mA 1.71 V ≤ V _{DD} ≤ 3.6 V	-	0.4	
V _{OH} ⁽³⁾	Output high level voltage	I _{IO} = -1.5 mA 1.71 V ≤ V _{DD} ≤ 3.6 V	V _{DD} - 0.4	-	

1. The I_{IO} current sourced or sunk by the device must always respect the absolute maximum rating specified in [Table 14](#), and the sum of the currents sourced or sunk by all the I/Os (I/O ports and control pins) must always respect the absolute maximum ratings ΣI_{IO}.
2. TTL and CMOS outputs are compatible with JEDEC standards JESD36 and JESD52.
3. Specified by design - Not tested in production.

Prerelease product(s)

Table 58. Output voltage characteristics for PC14 and PC15⁽¹⁾

Symbol	Parameter	Conditions ⁽³⁾	Min	Max	Unit
V _{OL}	Output low level voltage	CMOS port ⁽²⁾ , I _{IO} = 0.5 mA 2.7 V ≤ V _{DD} ≤ 3.6 V	-	0.4	V
V _{OH}	Output high level voltage	CMOS port ⁽²⁾ , I _{IO} = -0.5 mA 2.7 V ≤ V _{DD} ≤ 3.6 V	V _{DD} - 0.4	-	
V _{OL} ⁽³⁾	Output low level voltage	TTL port ⁽²⁾ , I _{IO} = 0.5 mA 2.7 V ≤ V _{DD} ≤ 3.6 V	-	0.4	
V _{OH} ⁽³⁾	Output high level voltage	TTL port ⁽²⁾ , I _{IO} = -0.5 mA 2.7 V ≤ V _{DD} ≤ 3.6 V	2.4	-	
V _{OL} ⁽³⁾	Output low level voltage	I _{IO} = 0.25 mA 1.71 V ≤ V _{DD} ≤ 3.6 V	-	0.4	
V _{OH} ⁽³⁾	Output high level voltage	I _{IO} = -0.25 mA 1.71 V ≤ V _{DD} ≤ 3.6 V	V _{DD} - 0.4	-	

1. The I_{IO} current sourced or sunk by the device must always respect the absolute maximum rating specified in [Table 14](#), and the sum of the currents sourced or sunk by all the I/Os (I/O ports and control pins) must always respect the absolute maximum ratings ΣI_{IO}.
2. TTL and CMOS outputs are compatible with JEDEC standards JESD36 and JESD52.
3. Specified by design - Not tested in production.

Output buffer timing characteristics (HSLV option disabled)

The HSLV bit of GPIOx_HSLVR register can be used to optimize the I/O speed when the voltage is below 2.7 V.

Prerelease product(s)

Table 59. Output timing characteristics (HSLV OFF)⁽¹⁾

Speed	Symbol	Parameter	Conditions	Min	Max	Unit
00	F _{max} ⁽²⁾⁽³⁾	Maximum frequency	C = 50 pF, 2.7 V ≤ V _{DD} ≤ 3.6 V	-	8	MHz
			C = 50 pF, 1.71 V ≤ V _{DD} ≤ 2 V	-	5	
			C = 40 pF, 2.7 V ≤ V _{DD} ≤ 3.6 V	-	10	
			C = 40 pF, 1.71 V ≤ V _{DD} ≤ 2 V	-	5	
			C = 30 pF, 2.7 V ≤ V _{DD} ≤ 3.6 V	-	12	
			C = 30 pF, 1.71 V ≤ V _{DD} ≤ 2 V	-	5	
			C = 20 pF, 2.7 V ≤ V _{DD} ≤ 3.6 V	-	14	
			C = 20 pF, 1.71 V ≤ V _{DD} ≤ 2 V	-	5	
			C = 10 pF, 2.7 V ≤ V _{DD} ≤ 3.6 V	-	16	
	C = 10 pF, 1.71 V ≤ V _{DD} ≤ 2 V	-	5			
	t _r /t _f ⁽⁴⁾⁽⁵⁾	Output high to low level fall time and output low to high level rise time	C = 50 pF, 2.7 V ≤ V _{DD} ≤ 3.6 V	-	18.0	ns
			C = 50 pF, 1.71 V ≤ V _{DD} ≤ 2 V	-	36.0	
			C = 40 pF, 2.7 V ≤ V _{DD} ≤ 3.6 V	-	17.0	
			C = 40 pF, 1.71 V ≤ V _{DD} ≤ 2 V	-	34.0	
			C = 30 pF, 2.7 V ≤ V _{DD} ≤ 3.6 V	-	15.5	
			C = 30 pF, 1.71 V ≤ V _{DD} ≤ 2 V	-	32.0	
			C = 20 pF, 2.7 V ≤ V _{DD} ≤ 3.6 V	-	14.2	
			C = 20 pF, 1.71 V ≤ V _{DD} ≤ 2 V	-	30.0	
			C = 10 pF, 2.7 V ≤ V _{DD} ≤ 3.6 V	-	12.2	
C = 10 pF, 1.71 V ≤ V _{DD} ≤ 2 V			-	27		

Prerelease product(s)

Table 59. Output timing characteristics (HSLV OFF)⁽¹⁾ (continued)

Speed	Symbol	Parameter	Conditions	Min	Max	Unit
01	F _{max} ⁽²⁾⁽³⁾	Maximum frequency	C = 50 pF, 2.7 V ≤ V _{DD} ≤ 3.6 V		40	MHz
			C = 50 pF, 1.71 V ≤ V _{DD} ≤ 2 V	-	12	
			C = 40 pF, 2.7 V ≤ V _{DD} ≤ 3.6 V	-	45	
			C = 40 pF, 1.71 V ≤ V _{DD} ≤ 2 V	-	14	
			C = 30 pF, 2.7 V ≤ V _{DD} ≤ 3.6 V	-	50	
			C = 30 pF, 1.71 V ≤ V _{DD} ≤ 2 V	-	16	
			C = 20 pF, 2.7 V ≤ V _{DD} ≤ 3.6 V	-	55	
			C = 20 pF, 1.71 V ≤ V _{DD} ≤ 2 V	-	18	
			C = 10 pF, 2.7 V ≤ V _{DD} ≤ 3.6 V	-	60	
			C = 10 pF, 1.71 V ≤ V _{DD} ≤ 2 V	-	20	
	t _r /t _f ⁽⁴⁾⁽⁵⁾	Output high to low level fall time and output low to high level rise time	C = 50 pF, 2.7 V ≤ V _{DD} ≤ 3.6 V	-	6.2	ns
			C = 50 pF, 1.71 V ≤ V _{DD} ≤ 2 V	-	11.4	
			C = 40 pF, 2.7 V ≤ V _{DD} ≤ 3.6 V	-	5.7	
			C = 40 pF, 1.71 V ≤ V _{DD} ≤ 2 V	-	10.5	
			C = 30 pF, 2.7 V ≤ V _{DD} ≤ 3.6 V	-	5.1	
			C = 30 pF, 1.71 V ≤ V _{DD} ≤ 2 V	-	9.5	
			C = 20 pF, 2.7 V ≤ V _{DD} ≤ 3.6 V	-	4.5	
			C = 20 pF, 1.71 V ≤ V _{DD} ≤ 2 V		8.4	
			C = 10 pF, 2.7 V ≤ V _{DD} ≤ 3.6 V		3.7	
C = 10 pF, 1.71 V ≤ V _{DD} ≤ 2 V		7.0				

Prerelease product(s)



Table 59. Output timing characteristics (HSLV OFF)⁽¹⁾ (continued)

Speed	Symbol	Parameter	Conditions	Min	Max	Unit
10	F _{max} ⁽²⁾⁽³⁾	Maximum frequency	C = 50 pF, 2.7 V ≤ V _{DD} ≤ 3.6 V	-	80	MHz
			C = 50 pF, 1.71 V ≤ V _{DD} ≤ 2 V	-	30	
			C = 40 pF, 2.7 V ≤ V _{DD} ≤ 3.6 V	-	90	
			C = 40 pF, 1.71 V ≤ V _{DD} ≤ 2 V	-	35	
			C = 30 pF, 2.7 V ≤ V _{DD} ≤ 3.6 V	-	100	
			C = 30 pF, 1.71 V ≤ V _{DD} ≤ 2 V	-	40	
			C = 20 pF, 2.7 V ≤ V _{DD} ≤ 3.6 V	-	110	
			C = 20 pF, 1.71 V ≤ V _{DD} ≤ 2 V	-	45	
			C = 10 pF, 2.7 V ≤ V _{DD} ≤ 3.6 V	-	133	
			C = 10 pF, 1.71 V ≤ V _{DD} ≤ 2 V	-	50	
	t _r /t _f ⁽⁴⁾⁽⁵⁾	Output high to low level fall time and output low to high level rise time	C = 50 pF, 2.7 V ≤ V _{DD} ≤ 3.6 V	-	3.8	ns
			C = 50 pF, 1.71 V ≤ V _{DD} ≤ 2 V	-	7.5	
			C = 40 pF, 2.7 V ≤ V _{DD} ≤ 3.6 V	-	3.4	
			C = 40 pF, 1.71 V ≤ V _{DD} ≤ 2 V	-	6.6	
			C = 30 pF, 2.7 V ≤ V _{DD} ≤ 3.6 V	-	2.9	
			C = 30 pF, 1.71 V ≤ V _{DD} ≤ 2 V	-	5.7	
			C = 20 pF, 2.7 V ≤ V _{DD} ≤ 3.6 V	-	2.5	
			C = 20 pF, 1.71 V ≤ V _{DD} ≤ 2 V	-	4.7	
			C = 10 pF, 2.7 V ≤ V _{DD} ≤ 3.6 V	-	1.9	
C = 10 pF, 1.71 V ≤ V _{DD} ≤ 2 V	-	3.7				

Prerelease product(s)

Table 59. Output timing characteristics (HSLV OFF)⁽¹⁾ (continued)

Speed	Symbol	Parameter	Conditions	Min	Max	Unit
11	F _{max} ⁽²⁾⁽³⁾	Maximum frequency	C = 50 pF, 2.7 V ≤ V _{DD} ≤ 3.6 V	-	100	MHz
			C = 50 pF, 1.71 V ≤ V _{DD} ≤ 2 V	-	40	
			C = 40 pF, 2.7 V ≤ V _{DD} ≤ 3.6 V	-	120	
			C = 40 pF, 1.71 V ≤ V _{DD} ≤ 2 V	-	50	
			C = 30 pF, 2.7 V ≤ V _{DD} ≤ 3.6 V	-	140	
			C = 30 pF, 1.71 V ≤ V _{DD} ≤ 2 V	-	60	
			C = 20 pF, 2.7 V ≤ V _{DD} ≤ 3.6 V	-	166	
			C = 20 pF, 1.71 V ≤ V _{DD} ≤ 2 V	-	70	
			C = 10 pF, 2.7 V ≤ V _{DD} ≤ 3.6 V	-	200	
			C = 10 pF, 1.71 V ≤ V _{DD} ≤ 2 V	-	80	
	t _r /t _f ⁽⁴⁾⁽⁵⁾	Output high to low level fall time and output low to high level rise time	C = 50 pF, 2.7 V ≤ V _{DD} ≤ 3.6 V	-	3.3	ns
			C = 50 pF, 1.71 V ≤ V _{DD} ≤ 2 V	-	6.3	
			C = 40 pF, 2.7 V ≤ V _{DD} ≤ 3.6 V	-	2.8	
			C = 40 pF, 1.71 V ≤ V _{DD} ≤ 2 V	-	5.5	
			C = 30 pF, 2.7 V ≤ V _{DD} ≤ 3.6 V	-	2.3	
			C = 30 pF, 1.71 V ≤ V _{DD} ≤ 2 V	-	4.6	
			C = 20 pF, 2.7 V ≤ V _{DD} ≤ 3.6 V	-	1.9	
			C = 20 pF, 1.71 V ≤ V _{DD} ≤ 2 V	-	3.7	
			C = 10 pF, 2.7 V ≤ V _{DD} ≤ 3.6 V	-	1.4	
C = 10 pF, 1.71 V ≤ V _{DD} ≤ 2 V	-	3				

1. Specified by design - Not tested in production.
2. The maximum frequency is defined with the conditions (t_r + t_f) ≤ 2/3 T, Skew ≤ 1/20 T, and 45% < Duty cycle < 55%.
3. When 2 V < V_{DD} < 2.7 V the maximum frequency is between values given for V_{DD} = 1.98 V and V_{DD} = 2.7 V.
4. The fall and rise times are defined between 90% and 10% and between 10% and 90% of the output waveform, respectively.
5. When 2 V < V_{DD} < 2.7 V the maximum t_{rise}/t_{fall} is between values given for V_{DD} = 1.98 V and V_{DD} = 2.7 V.

Prerelease product(s)

Output buffer timing characteristics (HSLV option enabled)

Table 60. Output timing characteristics (HSLV ON)⁽¹⁾

Speed	Symbol	Parameter	Conditions	Min	Max	Unit
00	$F_{\max}^{(2)}$	Maximum frequency	$C = 50 \text{ pF}, 1.71 \text{ V} \leq V_{\text{DD}} \leq 2 \text{ V}$	-	8	MHz
			$C = 40 \text{ pF}, 1.71 \text{ V} \leq V_{\text{DD}} \leq 2 \text{ V}$	-	10	
			$C = 30 \text{ pF}, 1.71 \text{ V} \leq V_{\text{DD}} \leq 2 \text{ V}$	-	12	
			$C = 20 \text{ pF}, 1.71 \text{ V} \leq V_{\text{DD}} \leq 2 \text{ V}$	-	14	
			$C = 10 \text{ pF}, 1.71 \text{ V} \leq V_{\text{DD}} \leq 2 \text{ V}$	-	16	
	$t_r/t_f^{(3)}$	Output high to low level fall time and output low to high level rise time	$C = 50 \text{ pF}, 1.71 \text{ V} \leq V_{\text{DD}} \leq 2 \text{ V}$	-	17.8	ns
			$C = 40 \text{ pF}, 1.71 \text{ V} \leq V_{\text{DD}} \leq 2 \text{ V}$	-	15.8	
			$C = 30 \text{ pF}, 1.71 \text{ V} \leq V_{\text{DD}} \leq 2 \text{ V}$	-	14.4	
			$C = 20 \text{ pF}, 1.71 \text{ V} \leq V_{\text{DD}} \leq 2 \text{ V}$	-	13.1	
			$C = 10 \text{ pF}, 1.71 \text{ V} \leq V_{\text{DD}} \leq 2 \text{ V}$	-	11.4	
01	$F_{\max}^{(2)}$	Maximum frequency	$C = 50 \text{ pF}, 1.71 \text{ V} \leq V_{\text{DD}} \leq 2 \text{ V}$	-	40	MHz
			$C = 40 \text{ pF}, 1.71 \text{ V} \leq V_{\text{DD}} \leq 2 \text{ V}$	-	45	
			$C = 30 \text{ pF}, 1.71 \text{ V} \leq V_{\text{DD}} \leq 2 \text{ V}$	-	50	
			$C = 20 \text{ pF}, 1.71 \text{ V} \leq V_{\text{DD}} \leq 2 \text{ V}$	-	55	
			$C = 10 \text{ pF}, 1.71 \text{ V} \leq V_{\text{DD}} \leq 2 \text{ V}$	-	60	
	$t_r/t_f^{(3)(4)}$	Output high to low level fall time and output low to high level rise time	$C = 50 \text{ pF}, 1.71 \text{ V} \leq V_{\text{DD}} \leq 2 \text{ V}$	-	7.2	ns
			$C = 40 \text{ pF}, 1.71 \text{ V} \leq V_{\text{DD}} \leq 2 \text{ V}$	-	6.5	
			$C = 30 \text{ pF}, 1.71 \text{ V} \leq V_{\text{DD}} \leq 2 \text{ V}$	-	5.6	
			$C = 20 \text{ pF}, 1.71 \text{ V} \leq V_{\text{DD}} \leq 2 \text{ V}$	-	4.8	
			$C = 10 \text{ pF}, 1.71 \text{ V} \leq V_{\text{DD}} \leq 2 \text{ V}$	-	3.8	
10	$F_{\max}^{(2)(4)}$	Maximum frequency	$C = 50 \text{ pF}, 1.71 \text{ V} \leq V_{\text{DD}} \leq 2 \text{ V}$	-	60	MHz
			$C = 40 \text{ pF}, 1.71 \text{ V} \leq V_{\text{DD}} \leq 2 \text{ V}$	-	70	
			$C = 30 \text{ pF}, 1.71 \text{ V} \leq V_{\text{DD}} \leq 2 \text{ V}$	-	90	
			$C = 20 \text{ pF}, 1.71 \text{ V} \leq V_{\text{DD}} \leq 2 \text{ V}$	-	110	
			$C = 10 \text{ pF}, 1.71 \text{ V} \leq V_{\text{DD}} \leq 2 \text{ V}$	-	140	
	$t_r/t_f^{(3)(4)}$	Output high to low level fall time and output low to high level rise time	$C = 50 \text{ pF}, 1.71 \text{ V} \leq V_{\text{DD}} \leq 2 \text{ V}$	-	5.3	ns
			$C = 40 \text{ pF}, 1.71 \text{ V} \leq V_{\text{DD}} \leq 2 \text{ V}$	-	4.6	
			$C = 30 \text{ pF}, 1.71 \text{ V} \leq V_{\text{DD}} \leq 2 \text{ V}$	-	3.8	
			$C = 20 \text{ pF}, 1.71 \text{ V} \leq V_{\text{DD}} \leq 2 \text{ V}$	-	3.0	
			$C = 10 \text{ pF}, 1.71 \text{ V} \leq V_{\text{DD}} \leq 2 \text{ V}$	-	2.2	

Table 60. Output timing characteristics (HSLV ON)⁽¹⁾ (continued)

Speed	Symbol	Parameter	Conditions	Min	Max	Unit
11	F _{max} ⁽²⁾⁽⁴⁾	Maximum frequency	C = 50 pF, 1.71 V ≤ V _{DD} ≤ 2 V	-	67	MHz
			C = 40 pF, 1.71 V ≤ V _{DD} ≤ 2 V	-	100	
			C = 30 pF, 1.71 V ≤ V _{DD} ≤ 2 V	-	120	
			C = 20 pF, 1.71 V ≤ V _{DD} ≤ 2 V	-	155	
			C = 10 pF, 1.71 V ≤ V _{DD} ≤ 2 V	-	200	
	t _r /t _f ⁽³⁾⁽⁴⁾	Output high to low level fall time and output low to high level rise time	C = 50 pF, 1.71 V ≤ V _{DD} ≤ 2 V	-	5.0	ns
			C = 40 pF, 1.71 V ≤ V _{DD} ≤ 2 V	-	4.1	
			C = 30 pF, 1.71 V ≤ V _{DD} ≤ 2 V	-	3.3	
			C = 20 pF, 1.71 V ≤ V _{DD} ≤ 2 V	-	2.5	
			C = 10 pF, 1.71 V ≤ V _{DD} ≤ 2 V	-	1.8	

1. Specified by design - Not tested in production.
2. The maximum frequency is defined with the conditions: (t_r+t_f) ≤ 2/3 T, Skew ≤ 1/20 T, 45% < Duty cycle < 55%.
3. The fall and rise times are defined, respectively, between 90 and 10% and between 10 and 90% of the output waveform.
4. Compensation system enabled.

Table 61. Output timing characteristics V_{DDIO2} 1.2 V range (HSLV OFF)⁽¹⁾

Speed	Symbol	Parameter	Conditions	Min	Max	Unit
00	F _{max} ⁽²⁾	Maximum frequency	C = 50 pF, 1.08 V ≤ V _{DDIO2} ≤ 1.32 V	-	1	MHz
			C = 40 pF, 1.08 V ≤ V _{DDIO2} ≤ 1.32 V	-	1	
			C = 30 pF, 1.08 V ≤ V _{DDIO2} ≤ 1.32 V	-	1	
			C = 20 pF, 1.08 V ≤ V _{DDIO2} ≤ 1.32 V	-	1	
			C = 10 pF, 1.08 V ≤ V _{DDIO2} ≤ 1.32 V	-	1	
	t _r /t _f ⁽³⁾	Output high to low level fall time and output low to high level rise time	C = 50 pF, 1.08 V ≤ V _{DDIO2} ≤ 1.32 V	-	83.0	ns
			C = 40 pF, 1.08 V ≤ V _{DDIO2} ≤ 1.32 V	-	79.0	
			C = 30 pF, 1.08 V ≤ V _{DDIO2} ≤ 1.32 V	-	46.0	
			C = 20 pF, 1.08 V ≤ V _{DDIO2} ≤ 1.32 V	-	72.0	
			C = 10 pF, 1.08 V ≤ V _{DDIO2} ≤ 1.32 V	-	68.0	

Prerelease product(s)

Table 61. Output timing characteristics V_{DDIO2} 1.2 V range (HSLV OFF)⁽¹⁾ (continued)

Speed	Symbol	Parameter	Conditions	Min	Max	Unit
01	$F_{max}^{(2)}$	Maximum frequency	$C = 50 \text{ pF}, 1.08 \text{ V} \leq V_{DDIO2} \leq 1.32 \text{ V}$	-	5	MHz
			$C = 40 \text{ pF}, 1.08 \text{ V} \leq V_{DDIO2} \leq 1.32 \text{ V}$	-	5	
			$C = 30 \text{ pF}, 1.08 \text{ V} \leq V_{DDIO2} \leq 1.32 \text{ V}$	-	5	
			$C = 20 \text{ pF}, 1.08 \text{ V} \leq V_{DDIO2} \leq 1.32 \text{ V}$	-	5	
			$C = 10 \text{ pF}, 1.08 \text{ V} \leq V_{DDIO2} \leq 1.32 \text{ V}$	-	5	
	$t_r/t_f^{(3)}$	Output high to low level fall time and output low to high level rise time	$C = 50 \text{ pF}, 1.08 \text{ V} \leq V_{DDIO2} \leq 1.32 \text{ V}$	-	24.5	ns
			$C = 40 \text{ pF}, 1.08 \text{ V} \leq V_{DDIO2} \leq 1.32 \text{ V}$	-	22.2	
			$C = 30 \text{ pF}, 1.08 \text{ V} \leq V_{DDIO2} \leq 1.32 \text{ V}$	-	20.0	
			$C = 20 \text{ pF}, 1.08 \text{ V} \leq V_{DDIO2} \leq 1.32 \text{ V}$	-	17.8	
			$C = 10 \text{ pF}, 1.08 \text{ V} \leq V_{DDIO2} \leq 1.32 \text{ V}$	-	15.0	
10	$F_{max}^{(2)}$	Maximum frequency	$C = 50 \text{ pF}, 1.08 \text{ V} \leq V_{DDIO2} \leq 1.32 \text{ V}$	-	10	MHz
			$C = 40 \text{ pF}, 1.08 \text{ V} \leq V_{DDIO2} \leq 1.32 \text{ V}$	-	10	
			$C = 30 \text{ pF}, 1.08 \text{ V} \leq V_{DDIO2} \leq 1.32 \text{ V}$	-	10	
			$C = 20 \text{ pF}, 1.08 \text{ V} \leq V_{DDIO2} \leq 1.32 \text{ V}$	-	10	
			$C = 10 \text{ pF}, 1.08 \text{ V} \leq V_{DDIO2} \leq 1.32 \text{ V}$	-	10	
	$t_r/t_f^{(3)}$	Output high to low level fall time and output low to high level rise time	$C = 50 \text{ pF}, 1.08 \text{ V} \leq V_{DDIO2} \leq 1.32 \text{ V}$	-	16.2	ns
			$C = 40 \text{ pF}, 1.08 \text{ V} \leq V_{DDIO2} \leq 1.32 \text{ V}$	-	14.3	
			$C = 30 \text{ pF}, 1.08 \text{ V} \leq V_{DDIO2} \leq 1.32 \text{ V}$	-	12.2	
			$C = 20 \text{ pF}, 1.08 \text{ V} \leq V_{DDIO2} \leq 1.32 \text{ V}$	-	10.0	
			$C = 10 \text{ pF}, 1.08 \text{ V} \leq V_{DDIO2} \leq 1.32 \text{ V}$	-	7.9	
11	$F_{max}^{(2)(4)}$	Maximum frequency	$C = 50 \text{ pF}, 1.08 \text{ V} \leq V_{DDIO2} \leq 1.32 \text{ V}$	-	20	MHz
			$C = 40 \text{ pF}, 1.08 \text{ V} \leq V_{DDIO2} \leq 1.32 \text{ V}$	-	23	
			$C = 30 \text{ pF}, 1.08 \text{ V} \leq V_{DDIO2} \leq 1.32 \text{ V}$	-	25	
			$C = 20 \text{ pF}, 1.08 \text{ V} \leq V_{DDIO2} \leq 1.32 \text{ V}$	-	28	
			$C = 10 \text{ pF}, 1.08 \text{ V} \leq V_{DDIO2} \leq 1.32 \text{ V}$	-	30	
	$t_r/t_f^{(3)(4)}$	Output high to low level fall time and output low to high level rise time	$C = 50 \text{ pF}, 1.08 \text{ V} \leq V_{DDIO2} \leq 1.32 \text{ V}$	-	14.0	ns
			$C = 40 \text{ pF}, 1.08 \text{ V} \leq V_{DDIO2} \leq 1.32 \text{ V}$	-	12.0	
			$C = 30 \text{ pF}, 1.08 \text{ V} \leq V_{DDIO2} \leq 1.32 \text{ V}$	-	10.0	
			$C = 20 \text{ pF}, 1.08 \text{ V} \leq V_{DDIO2} \leq 1.32 \text{ V}$	-	8.0	
			$C = 10 \text{ pF}, 1.08 \text{ V} \leq V_{DDIO2} \leq 1.32 \text{ V}$	-	6.0	

1. Specified by design - Not tested in production.
2. The maximum frequency is defined with the conditions $(t_r + t_f) \leq 2/3 T$, $Skew \leq 1/20 T$, $45\% < \text{Duty cycle} < 55\%$.
3. The fall and rise times are defined between 90% and 10% and between 10% and 90% of the output waveform, respectively.
4. Compensation system enabled.

Prerelease product(s)

Table 62. Output timing characteristics V_{DDIO2} 1.2 V (HSLV ON)⁽¹⁾

Speed	Symbol	Parameter	Conditions	Min	Max	Unit
00	$F_{max}^{(2)}$	Maximum frequency	$C = 50 \text{ pF}, 1.08 \text{ V} \leq V_{DDIO2} \leq 1.32 \text{ V}$	-	5	MHz
			$C = 40 \text{ pF}, 1.08 \text{ V} \leq V_{DDIO2} \leq 1.32 \text{ V}$	-	5	
			$C = 30 \text{ pF}, 1.08 \text{ V} \leq V_{DDIO2} \leq 1.32 \text{ V}$	-	5	
			$C = 20 \text{ pF}, 1.08 \text{ V} \leq V_{DDIO2} \leq 1.32 \text{ V}$	-	5	
			$C = 10 \text{ pF}, 1.08 \text{ V} \leq V_{DDIO2} \leq 1.32 \text{ V}$	-	5	
	$t_r/t_f^{(3)}$	Output high to low level fall time and output low to high level rise time	$C = 50 \text{ pF}, 1.08 \text{ V} \leq V_{DDIO2} \leq 1.32 \text{ V}$	-	32.5	ns
			$C = 40 \text{ pF}, 1.08 \text{ V} \leq V_{DDIO2} \leq 1.32 \text{ V}$	-	30.0	
			$C = 30 \text{ pF}, 1.08 \text{ V} \leq V_{DDIO2} \leq 1.32 \text{ V}$	-	27.5	
			$C = 20 \text{ pF}, 1.08 \text{ V} \leq V_{DDIO2} \leq 1.32 \text{ V}$	-	25.0	
			$C = 10 \text{ pF}, 1.08 \text{ V} \leq V_{DDIO2} \leq 1.32 \text{ V}$	-	22.5	
01	$F_{max}^{(2)}$	Maximum frequency	$C = 50 \text{ pF}, 1.08 \text{ V} \leq V_{DDIO2} \leq 1.32 \text{ V}$	-	15.0	MHz
			$C = 40 \text{ pF}, 1.08 \text{ V} \leq V_{DDIO2} \leq 1.32 \text{ V}$	-	17.5	
			$C = 30 \text{ pF}, 1.08 \text{ V} \leq V_{DDIO2} \leq 1.32 \text{ V}$	-	20.0	
			$C = 20 \text{ pF}, 1.08 \text{ V} \leq V_{DDIO2} \leq 1.32 \text{ V}$	-	22.5	
			$C = 10 \text{ pF}, 1.08 \text{ V} \leq V_{DDIO2} \leq 1.32 \text{ V}$	-	25.0	
	$t_r/t_f^{(3)}$	Output high to low level fall time and output low to high level rise time	$C = 50 \text{ pF}, 1.08 \text{ V} \leq V_{DDIO2} \leq 1.32 \text{ V}$	-	14.6	ns
			$C = 40 \text{ pF}, 1.08 \text{ V} \leq V_{DDIO2} \leq 1.32 \text{ V}$	-	12.9	
			$C = 30 \text{ pF}, 1.08 \text{ V} \leq V_{DDIO2} \leq 1.32 \text{ V}$	-	11.2	
			$C = 20 \text{ pF}, 1.08 \text{ V} \leq V_{DDIO2} \leq 1.32 \text{ V}$	-	9.3	
			$C = 10 \text{ pF}, 1.08 \text{ V} \leq V_{DDIO2} \leq 1.32 \text{ V}$	-	7.3	
10	$F_{max}^{(2)(4)}$	Maximum frequency	$C = 50 \text{ pF}, 1.08 \text{ V} \leq V_{DDIO2} \leq 1.32 \text{ V}$	-	25	MHz
			$C = 40 \text{ pF}, 1.08 \text{ V} \leq V_{DDIO2} \leq 1.32 \text{ V}$	-	30	
			$C = 30 \text{ pF}, 1.08 \text{ V} \leq V_{DDIO2} \leq 1.32 \text{ V}$	-	33	
			$C = 20 \text{ pF}, 1.08 \text{ V} \leq V_{DDIO2} \leq 1.32 \text{ V}$	-	44	
			$C = 10 \text{ pF}, 1.08 \text{ V} \leq V_{DDIO2} \leq 1.32 \text{ V}$	-	55	
	$t_r/t_f^{(3)(4)}$	Output high to low level fall time and output low to high level rise time	$C = 50 \text{ pF}, 1.08 \text{ V} \leq V_{DDIO2} \leq 1.32 \text{ V}$	-	11.6	ns
			$C = 40 \text{ pF}, 1.08 \text{ V} \leq V_{DDIO2} \leq 1.32 \text{ V}$	-	9.7	
			$C = 30 \text{ pF}, 1.08 \text{ V} \leq V_{DDIO2} \leq 1.32 \text{ V}$	-	7.8	
			$C = 20 \text{ pF}, 1.08 \text{ V} \leq V_{DDIO2} \leq 1.32 \text{ V}$	-	6.1	
			$C = 10 \text{ pF}, 1.08 \text{ V} \leq V_{DDIO2} \leq 1.32 \text{ V}$	-	4.3	

Prerelease product(s)

Table 62. Output timing characteristics V_{DDIO2} 1.2 V (HSLV ON)⁽¹⁾ (continued)

Speed	Symbol	Parameter	Conditions	Min	Max	Unit
11	$F_{max}^{(2)(4)}$	Maximum frequency	$C = 50 \text{ pF}, 1.08 \text{ V} \leq V_{DDIO2} \leq 1.32 \text{ V}$	-	30	MHz
			$C = 40 \text{ pF}, 1.08 \text{ V} \leq V_{DDIO2} \leq 1.32 \text{ V}$	-	35	
			$C = 30 \text{ pF}, 1.08 \text{ V} \leq V_{DDIO2} \leq 1.32 \text{ V}$	-	44	
			$C = 20 \text{ pF}, 1.08 \text{ V} \leq V_{DDIO2} \leq 1.32 \text{ V}$	-	55	
			$C = 10 \text{ pF}, 1.08 \text{ V} \leq V_{DDIO2} \leq 1.32 \text{ V}$	-	77	
	$t_r/t_f^{(3)(4)}$	Output high to low level fall time and output low to high level rise time	$C = 50 \text{ pF}, 1.08 \text{ V} \leq V_{DDIO2} \leq 1.32 \text{ V}$	-	11.1	ns
			$C = 40 \text{ pF}, 1.08 \text{ V} \leq V_{DDIO2} \leq 1.32 \text{ V}$	-	9.2	
			$C = 30 \text{ pF}, 1.08 \text{ V} \leq V_{DDIO2} \leq 1.32 \text{ V}$	-	7.2	
			$C = 20 \text{ pF}, 1.08 \text{ V} \leq V_{DDIO2} \leq 1.32 \text{ V}$	-	5.4	
			$C = 10 \text{ pF}, 1.08 \text{ V} \leq V_{DDIO2} \leq 1.32 \text{ V}$	-	3.6	

1. Specified by design - Not tested in production.
2. The maximum frequency is defined with the conditions $(t_r + t_f) \leq 2/3 T$, Skew $\leq 1/20 T$, 45% < Duty cycle < 55%.
3. The fall and rise times are defined between 90% and 10% and between 10% and 90% of the output waveform, respectively.
4. Compensation system enabled.

Table 63. Output timing characteristics for FT_c I/Os (PB13/PB14)⁽¹⁾⁽²⁾

Speed	Symbol	Parameter	Conditions	Min	Max	Unit
00	F_{max}	Maximum frequency	$C = 50 \text{ pF}, 2.7 \text{ V} \leq V_{DDIO} \leq 3.6 \text{ V}$	-	2	MHz
			$C = 50 \text{ pF}, 1.71 \text{ V} \leq V_{DDIO} < 2.7 \text{ V}$	-	1	
	t_r/t_f	Output rise and fall time	$C = 50 \text{ pF}, 2.7 \text{ V} \leq V_{DDIO} < 3.6 \text{ V}$	-	166	ns
			$C = 50 \text{ pF}, 1.71 \text{ V} \leq V_{DDIO} < 2.7 \text{ V}$	-	330	
01	F_{rmax}	Maximum frequency	$C = 30 \text{ pF}, 2.7 \text{ V} \leq V_{DDIO} < 3.6 \text{ V}$	-	10	MHz
			$C = 30 \text{ pF}, 1.71 \text{ V} \leq V_{DDIO} < 2.7 \text{ V}$	-	4	
	t_r/t_f	Output rise and fall time	$C = 30 \text{ pF}, 2.7 \text{ V} \leq V_{DDIO} < 3.6 \text{ V}$	-	33	ns
			$C = 30 \text{ pF}, 1.71 \text{ V} \leq V_{DDIO} < 2.7 \text{ V}$	-	65	

1. Specified by design - Not tested in production.
2. The I/O speed is configured using the OSPEEDRy[1:0] bits. Refer to the product reference manual for a description of GPIO port configuration register.

5.3.15 NRST pin characteristics

The NRST pin input driver uses CMOS technology. It is connected to a permanent pull-up resistor, R_{PU} (see [Table 54](#)).

Unless otherwise specified, the parameters in [Table 64](#) are derived from tests performed under the ambient temperature and V_{DD} supply voltage conditions summarized in [Table 17](#).

Table 64. NRST pin characteristics

Symbol	Parameter	Conditions	Min	Typ	Max	Unit
$R_{PU}^{(2)}$	Weak pull-up equivalent resistor ⁽¹⁾	$V_{IN} = V_{SS}$	30	40	50	kΩ
$V_{F(NRST)}^{(2)}$	NRST input filtered pulse	$1.71\text{ V} < V_{DD} < 3.6\text{ V}$	-	-	50	ns
$V_{NF(NRST)}^{(2)}$	NRST input not filtered pulse	$1.71\text{ V} < V_{DD} < 3.6\text{ V}$	350	-	-	

1. The pull-up is designed with a true resistance in series with a switchable PMOS. The PMOS contribution to the series resistance is minimum (~10 % order).
2. Specified by design - Not tested in production.

Figure 24. Recommended NRST pin protection

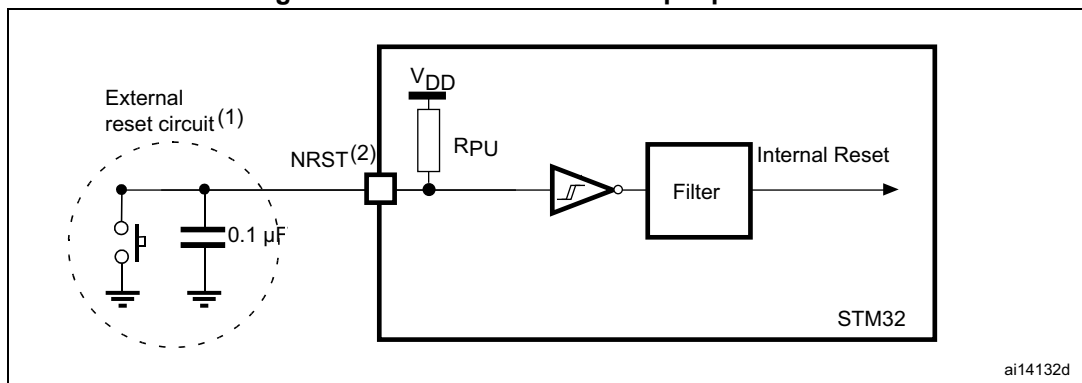

1. The reset network protects the device against parasitic resets.
2. The user must ensure that the level on the NRST pin can go below the $V_{IL(NRST)}$ max level specified in [Table 54](#), otherwise the reset is not taken into account by the device.

5.3.16 Extended interrupt and event controller input (EXTI) characteristics

The pulse on the interrupt input must have a minimal length to ensure its detection by the event controller.

Table 65. EXTI input characteristics⁽¹⁾

Symbol	Parameter	Conditions	Min	Typ	Max	Unit
PLEC	Pulse length to event controller	-	20	-	-	ns

1. Specified by design - Not tested in production.

5.3.17 PLAY characteristics

Unless otherwise specified, the parameters in the following tables are derived from tests performed under the ambient temperature and supply voltage conditions summarized in [Table 66](#).

- Output speed is set to $OSPEEDRy[1:0] = 11$
- Capacitive load $C = 30\text{ pF}$
- IO Compensation cell activated.
- VOS level set to VOS0
- HSLV activated when $V_{DD} \leq 2.7\text{ V}$

Table 66. PLAY timing measurement⁽¹⁾

Symbol	Parameter	Conditions	Min	Typ	Max	Unit
t_{pd}	Propagation delay from input I/Os to output I/Os	Maximum PLAY propagation delay for each LUT from input I/Os to output I/Os	-	11.5/24 ⁽²⁾	-	ns
$t_{pd(comp)}$		Propagation delay from comparator COMPx_INP input pin to PLAY output pin	-	46	-	

1. Evaluated by characterization - Not tested in production.
2. When using PLAY1_OUT2.

Table 67. PLAY filter characteristics⁽¹⁾

Symbol	Parameter	Min	Max	Unit
t_{PF}	Maximum pulse length that is guaranteed to be filtered	-	$(N - 1) * T_{CK} - 2.5^{(2)}$	ns
t_{PP}	Minimum pulse length that is guaranteed to pass	$N * T_{CK} + 2.5$	-	

1. Evaluated by characterization - Not tested in production.
2. N is the minimum pulse length, in periods of play_clk, programmed in the filter.

Figure 25. PLAY timing diagram

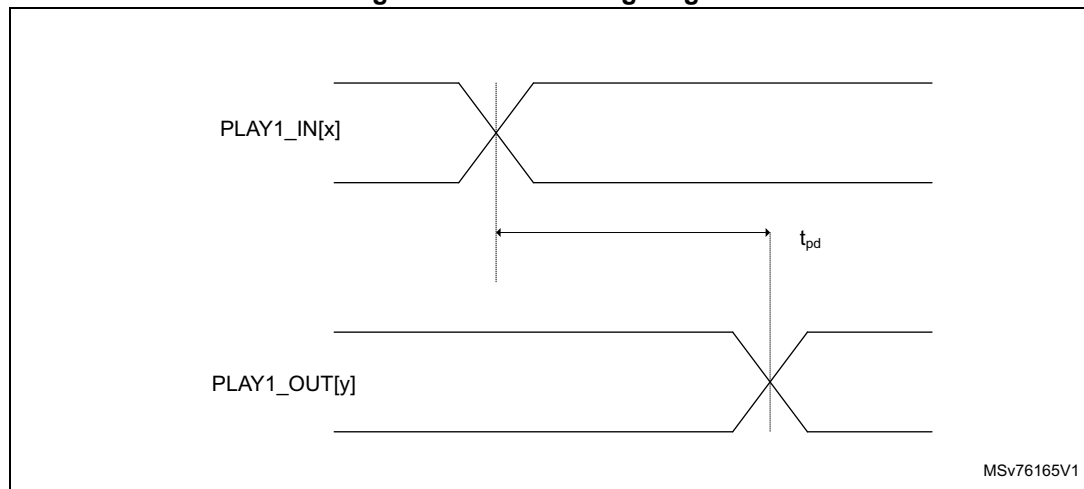

Prerelease product(s)

5.3.18 FMC characteristics

Unless otherwise specified, the parameters given in tables 68 to 81 are derived from tests performed under the ambient temperature, f_{HCLK} frequency, and V_{DD} supply voltage conditions summarized in Table 17, with the following configuration:

- Output speed is set to $\text{OSPEEDRy}[1:0] = 11$
- Measurement points are done at CMOS levels: $0.5 V_{\text{DD}}$
- I/O compensation cell activated
- HSLV activated when $V_{\text{DD}} \leq 2.7 \text{ V}$
- VOS level set to VOS0

Refer to Section 5.3.14 for more details on the input/output alternate function characteristics.

Asynchronous waveforms and timings

Figures 26 through 28 represent asynchronous waveforms, tables 68 through 75 provide the corresponding timings. The results shown in these tables are obtained with the following FMC configuration:

- $\text{AddressSetupTime} = 0x1$
- $\text{AddressHoldTime} = 0x1$
- $\text{DataSetupTime} = 0x1$ (except for asynchronous NWAIT mode, $\text{DataSetupTime} = 0x5$)
- $\text{BusTurnAroundDuration} = 0x0$
- Capacitive load $C_L = 30 \text{ pF}$

In all timing tables, the $T_{\text{fmc_ker_ck}}$ is the f_{HCLK} clock period.

Figure 26. Asynchronous non-multiplexed SRAM/PSRAM/NOR read waveforms

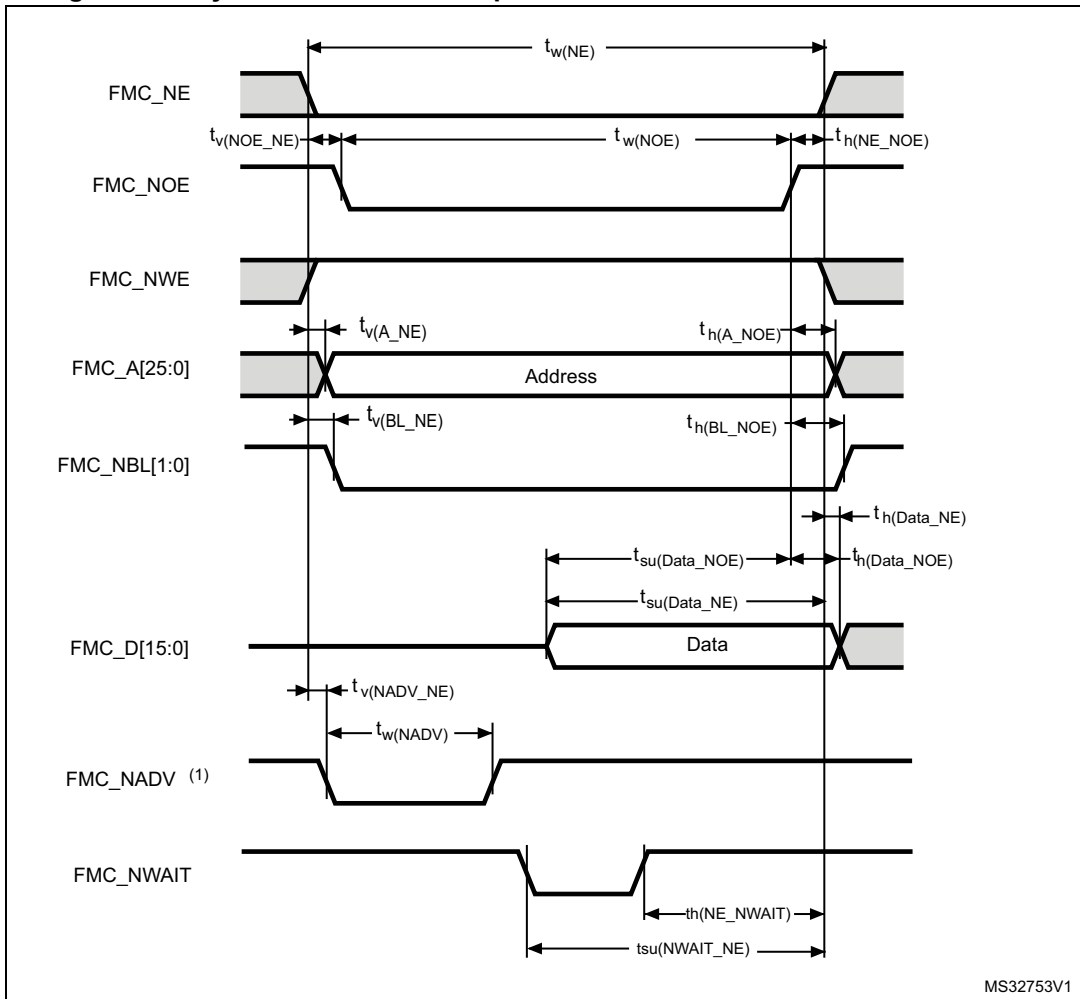

MS32753V1

1. Mode 2/B, C and D only. In Mode 1, FMC_NADV is not used.

Prerelease product(s)

Table 68. Asynchronous non-multiplexed SRAM/PSRAM/NOR read timings⁽¹⁾

Symbol	Parameter	Min	Max	Unit
$t_{w(NE)}$	FMC_NE low time	$3 T_{fmc_ker_ck} - 1$	$3 T_{fmc_ker_ck} + 1$	ns
$t_{v(NO_NE)}$	FMC_NEx low to FMC_NOE low	0	0.5	
$t_{w(NOE)}$	FMC_NOE low time	$2 T_{fmc_ker_ck} - 1$	$2 T_{fmc_ker_ck} + 1$	
$t_{h(NE_NOE)}$	FMC_NOE high to FMC_NE high hold time	$T_{fmc_ker_ck} - 0.5$	-	
$t_{v(A_NE)}$	FMC_NEx low to FMC_A valid	-	1	
$t_{h(A_NOE)}$	Address hold time after FMC_NOE high	$2 T_{fmc_ker_ck} - 1.5$	-	
$t_{su(Data_NE)}$	Data to FMC_NEx high setup time	$T_{fmc_ker_ck} + 10$	-	
$t_{su(Data_NOE)}$	Data to FMC_NOEx high setup time	9	-	
$t_{h(Data_NOE)}$	Data hold time after FMC_NOE high	0	-	
$t_{h(Data_NE)}$	Data hold time after FMC_NEx high	0	-	
$t_{v(NADV_NE)}$	FMC_NEx low to FMC_NADV low	-	0.5	
$t_{w(NADV)}$	FMC_NADV low time	-	$T_{fmc_ker_ck} + 1$	

1. Evaluated by characterization - Not tested in production.

Table 69. Asynchronous non-multiplexed SRAM/PSRAM/NOR read-NWAIT timings⁽¹⁾⁽²⁾

Symbol	Parameter	Min	Max	Unit
$t_{w(NE)}$	FMC_NE low time	$8 T_{fmc_ker_ck} - 1$	$8 T_{fmc_ker_ck} + 1$	ns
$t_{w(NOE)}$	FMC_NOE low time	$7 T_{fmc_ker_ck} - 1$	$7 T_{fmc_ker_ck} + 1$	
$t_{w(NWAIT)}$	FMC_NWAIT low time	$T_{fmc_ker_ck} - 0.5$	-	
$t_{su(NWAIT_NE)}$	FMC_NWAIT valid before FMC_NEx high	$5 T_{fmc_ker_ck} + 10$	-	
$t_{h(NE_NWAIT)}$	FMC_NEx hold time after FMC_NWAIT invalid	$4 T_{fmc_ker_ck} + 10$	-	

1. Evaluated by characterization - Not tested in production.

2. N_{WAIT} pulse width is equal to one fmc_ker_ck cycle.

Prerelease product(s)

Figure 27. Asynchronous non-multiplexed SRAM/PSRAM/NOR write waveforms

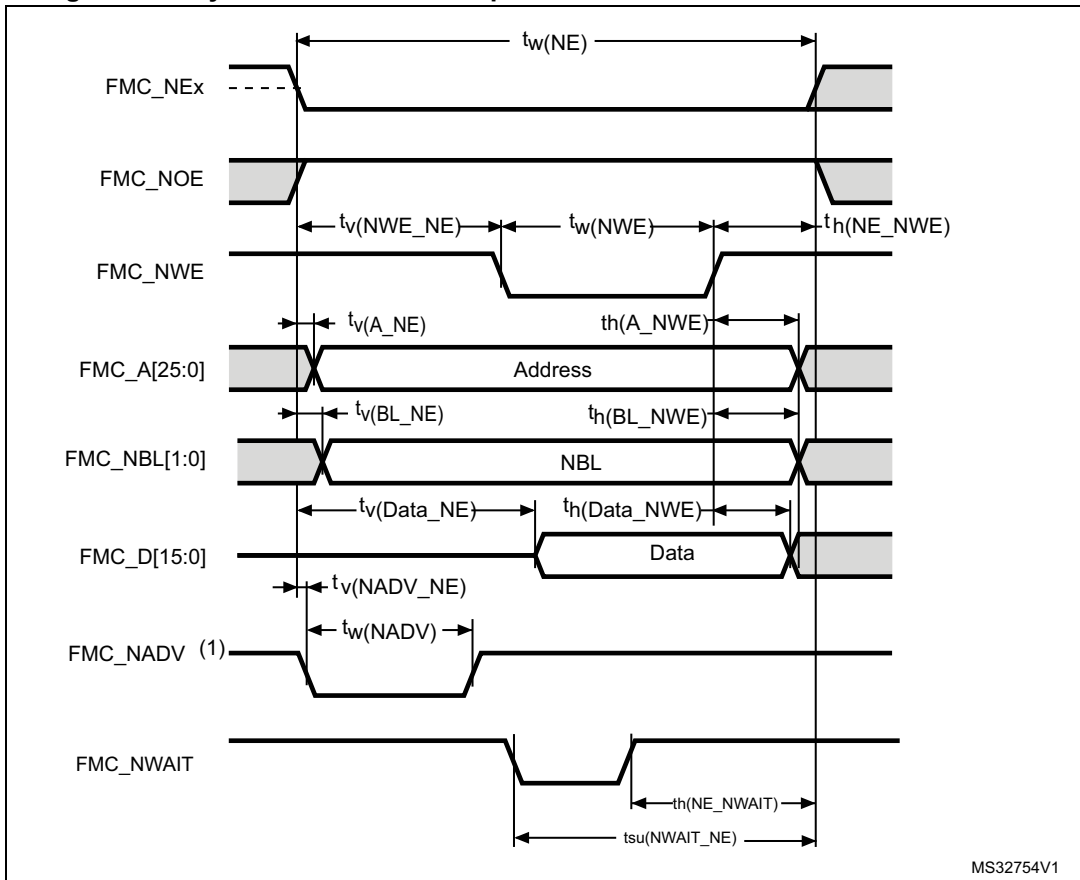

MS32754V1

1. Mode 2/B, C and D only. In Mode 1, FMC_NADV is not used.

Table 70. Asynchronous non-multiplexed SRAM/PSRAM/NOR write timings⁽¹⁾

Symbol	Parameter	Min	Max	Unit
$t_{w(NE)}$	FMC_NE low time	$3 T_{fmc_ker_ck} - 1$	$3 T_{fmc_ker_ck} + 1$	ns
$t_{v(NWE_NE)}$	FMC_NEx low to FMC_NWE low	$T_{fmc_ker_ck} - 1$	$T_{fmc_ker_ck} + 0.5$	
$t_{w(NWE)}$	FMC_NWE low time	$T_{fmc_ker_ck} - 1$	$T_{fmc_ker_ck} + 1$	
$t_{h(NE_NWE)}$	FMC_NWE high to FMC_NE high hold time	$T_{fmc_ker_ck} - 1$	-	
$t_{v(A_NE)}$	FMC_NEx low to FMC_A valid	-	0.5	
$t_{h(A_NWE)}$	Address hold time after FMC_NWE high	$T_{fmc_ker_ck} - 1$	-	
$t_{v(BL_NE)}$	FMC_NEx low to FMC_BL valid	-	0.5	
$t_{h(BL_NWE)}$	FMC_BL hold time after FMC_NWE high	$T_{fmc_ker_ck} - 1$	-	
$t_{v(Data_NE)}$	Data to FMC_NEx low to Data valid	-	$T_{fmc_ker_ck} + 1$	
$t_{h(Data_NWE)}$	Data hold time after FMC_NWE high	$T_{fmc_ker_ck}$	-	
$t_{v(NADV_NE)}$	FMC_NEx low to FMC_NADV low	-	0.5	
$t_{w(NADV)}$	FMC_NADV low time	-	$T_{fmc_ker_ck} + 1$	

1. Evaluated by characterization - Not tested in production.

Table 71. Asynchronous non-multiplexed SRAM/PSRAM/NOR write-NWAIT timings⁽¹⁾⁽²⁾

Symbol	Parameter	Min	Max	Unit
$t_{w(NE)}$	FMC_NE low time	$8 T_{fmc_ker_ck} - 1$	$8 T_{fmc_ker_ck} + 1$	ns
$t_{w(NWE)}$	FMC_NWE low time	$6 T_{fmc_ker_ck} - 1$	$6 T_{fmc_ker_ck} + 1$	
$t_{su(NWAIT_NE)}$	FMC_NWAIT valid before FMC_NEx high	$5 T_{fmc_ker_ck} + 10$	-	
$t_{h(NE_NWAIT)}$	FMC_NEx hold time after FMC_NWAIT invalid	$4 T_{fmc_ker_ck} + 10$	-	

1. Evaluated by characterization - Not tested in production.
2. N_{WAIT} pulse width is equal to one fmc_ker_ck cycle.

Figure 28. Asynchronous multiplexed PSRAM/NOR read waveforms

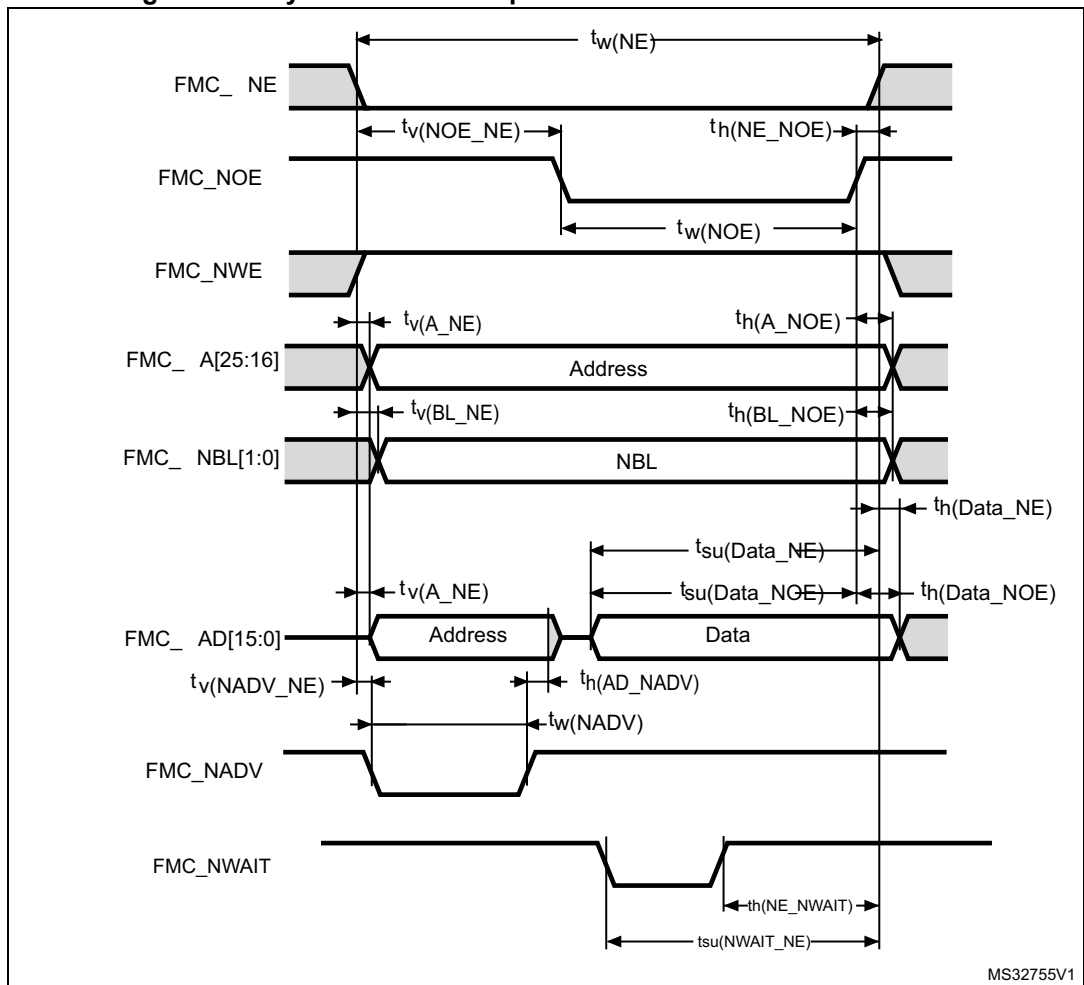

MS32755V1

Prerelease product(s)

Table 72. Asynchronous multiplexed PSRAM/NOR read timings⁽¹⁾

Symbol	Parameter	Min	Max	Unit
$t_{w(NE)}$	FMC_NE low time	$4 T_{fmc_ker_ck} - 1$	$4 T_{fmc_ker_ck} + 1$	ns
$t_{v(NOEN_NE)}$	FMC_NEx low to FMC_NOE low	$2 T_{fmc_ker_ck} - 1$	$2 T_{fmc_ker_ck} + 0.5$	
$t_{tw(NOEN)}$	FMC_NOE low time	$T_{fmc_ker_ck} - 1$	$T_{fmc_ker_ck} + 1$	
$t_{h(NE_NOEN)}$	FMC_NOE high to FMC_NE high hold time	$T_{fmc_ker_ck} - 0.5$	-	
$t_{v(A_NE)}$	FMC_NEx low to FMC_A valid	-	1	
$t_{v(NADV_NE)}$	FMC_NEx low to FMC_NADV low	0	1	
$t_{w(NADV)}$	FMC_NADV low time	$T_{fmc_ker_ck} - 0.5$	$T_{fmc_ker_ck} + 1$	
$t_{h(AD_NADV)}$	FMC_AD(address) valid hold time after FMC_NADV high	$T_{fmc_ker_ck} + 0.5$	-	
$t_{h(A_NOEN)}$	Address hold time after FMC_NOE high	$2 T_{fmc_ker_ck} - 0.5$	-	
$t_{su(Data_NE)}$	Data to FMC_NEx high setup time	$T_{fmc_ker_ck} + 10$	-	
$t_{su(Data_NOEN)}$	Data to FMC_NOE high setup time	9	-	
$t_{h(Data_NE)}$	Data hold time after FMC_NEx high	0	-	
$t_{h(Data_NOEN)}$	Data hold time after FMC_NOE high	0	-	

1. Evaluated by characterization - Not tested in production.

Table 73. Asynchronous multiplexed PSRAM/NOR read-NWAIT timings^{(1) (2)}

Symbol	Parameter	Min	Max	Unit
$t_{w(NE)}$	FMC_NE low time	$9 T_{fmc_ker_ck} - 1$	$9 T_{fmc_ker_ck} + 1$	ns
$t_{w(NOEN)}$	FMC_NOE low time	$7 T_{fmc_ker_ck} - 1$	$7 T_{fmc_ker_ck} + 1$	
$t_{su(NWAIT_NE)}$	FMC_NWAIT valid before FMC_NEx high	$4 T_{fmc_ker_ck} + 10$	-	
$t_{h(NE_NWAIT)}$	FMC_NEx hold time after FMC_NWAIT invalid	$3 T_{fmc_ker_ck} + 10$	-	

1. Evaluated by characterization - Not tested in production.

2. NWAIT pulse width is equal to one fmc_ker_ck cycle.

Prerelease product(s)

Figure 29. Asynchronous multiplexed PSRAM/NOR write waveforms

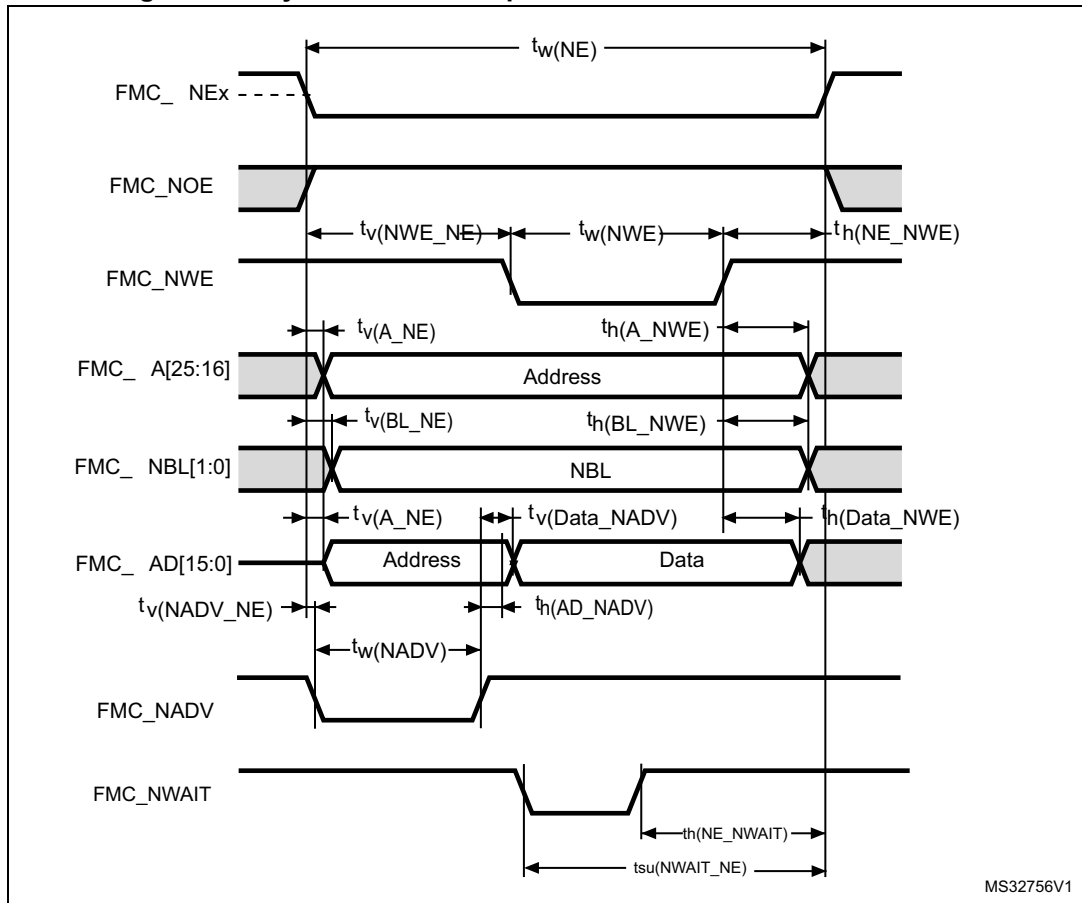

MS32756V1

Prerelease product(s)

Table 74. Asynchronous multiplexed PSRAM/NOR write timings⁽¹⁾

Symbol	Parameter	Min	Max	Unit
$t_{w(NE)}$	FMC_NE low time	$4 T_{fmc_ker_ck} - 1$	$4 T_{fmc_ker_ck} + 1$	ns
$t_{v(NWE_NE)}$	FMC_NEx low to FMC_NWE low	$T_{fmc_ker_ck} - 1$	$T_{fmc_ker_ck} + 0.5$	
$t_{w(NWE)}$	FMC_NWE low time	$2 T_{fmc_ker_ck} - 1$	$2 T_{fmc_ker_ck} + 1$	
$t_{h(NE_NWE)}$	FMC_NWE high to FMC_NE high hold time	$T_{fmc_ker_ck} - 0.5$	-	
$t_{v(A_NE)}$	FMC_NEx low to FMC_A valid	-	0.5	
$t_{v(NADV_NE)}$	FMC_NEx low to FMC_NADV low	0	1	
$t_{w(NADV)}$	FMC_NADV low time	$T_{fmc_ker_ck} - 1$	$T_{fmc_ker_ck} + 1$	
$t_{h(AD_NADV)}$	FMC_AD(address) valid hold time after FMC_NADV high	$T_{fmc_ker_ck} - 1$	-	
$t_{h(A_NWE)}$	Address hold time after FMC_NWE high	$T_{fmc_ker_ck} - 1$	-	
$t_{h(BL_NWE)}$	FMC_BL hold time after FMC_NWE high	$T_{fmc_ker_ck} - 1$	-	
$t_{v(BL_NE)}$	FMC_NEx low to FMC_BL valid	-	0.5	
$t_{v(Data_NADV)}$	FMC_NADV high to Data valid	-	$T_{fmc_ker_ck} + 0.5$	
$t_{h(Data_NWE)}$	Data hold time after FMC_NWE high	$T_{fmc_ker_ck} - 0.5$	-	

1. Evaluated by characterization - Not tested in production.

Table 75. Asynchronous multiplexed PSRAM/NOR write-NWAIT timings⁽¹⁾⁽²⁾

Symbol	Parameter	Min	Max	Unit
$t_{w(NE)}$	FMC_NE low time	$9 T_{fmc_ker_ck} - 1$	$9 T_{fmc_ker_ck} + 1$	ns
$t_{w(NWE)}$	FMC_NWE low time	$7 T_{fmc_ker_ck} - 1$	$7 T_{fmc_ker_ck} + 1$	
$t_{su(NWAIT_NE)}$	FMC_NWAIT valid before FMC_NEx high	$5 T_{fmc_ker_ck} + 10$	-	
$t_{h(NE_NWAIT)}$	FMC_NEx hold time after FMC_NWAIT invalid	$4 T_{fmc_ker_ck} + 10$	-	

1. Evaluated by characterization - Not tested in production.

2. N_{WAIT} pulse width is equal to one fmc_ker_ck cycle.

Prerelease product(s)

Synchronous waveforms and timings

Figures 30 through 33 represent synchronous waveforms, tables 76 through 79 provide the corresponding timings. The results shown in these tables are obtained with the following FMC configuration:

- BurstAccessMode = FMC_BurstAccessMode_Enable
- MemoryType = FMC_MemoryType_CRAM
- WriteBurst = FMC_WriteBurst_Enable
- CLKDivision = 1
- DataLatency = 1 for NOR flash, DataLatency = 0 for PSRAM.
- With capacity load $C_L = 30$ pF

In all the timing tables, $T_{fmc_ker_ck}$ is the $f_{fmc_ker_ck}$ clock period, with the following FMC_CLK maximum values:

- For $2.7\text{ V} < V_{DD} < 3.6\text{ V}$: maximum FMC_CLK = 100 MHz at $C_L = 20$ pF
- For $1.71\text{ V} < V_{DD} < 1.8\text{ V}$: maximum FMC_CLK = 95 MHz at $C_L = 20$ pF
- For $1.71\text{ V} < V_{DD} < 1.8\text{ V}$: maximum FMC_CLK = 100 MHz at $C_L = 15$ pF

Figure 30. Synchronous multiplexed NOR/PSRAM read timings

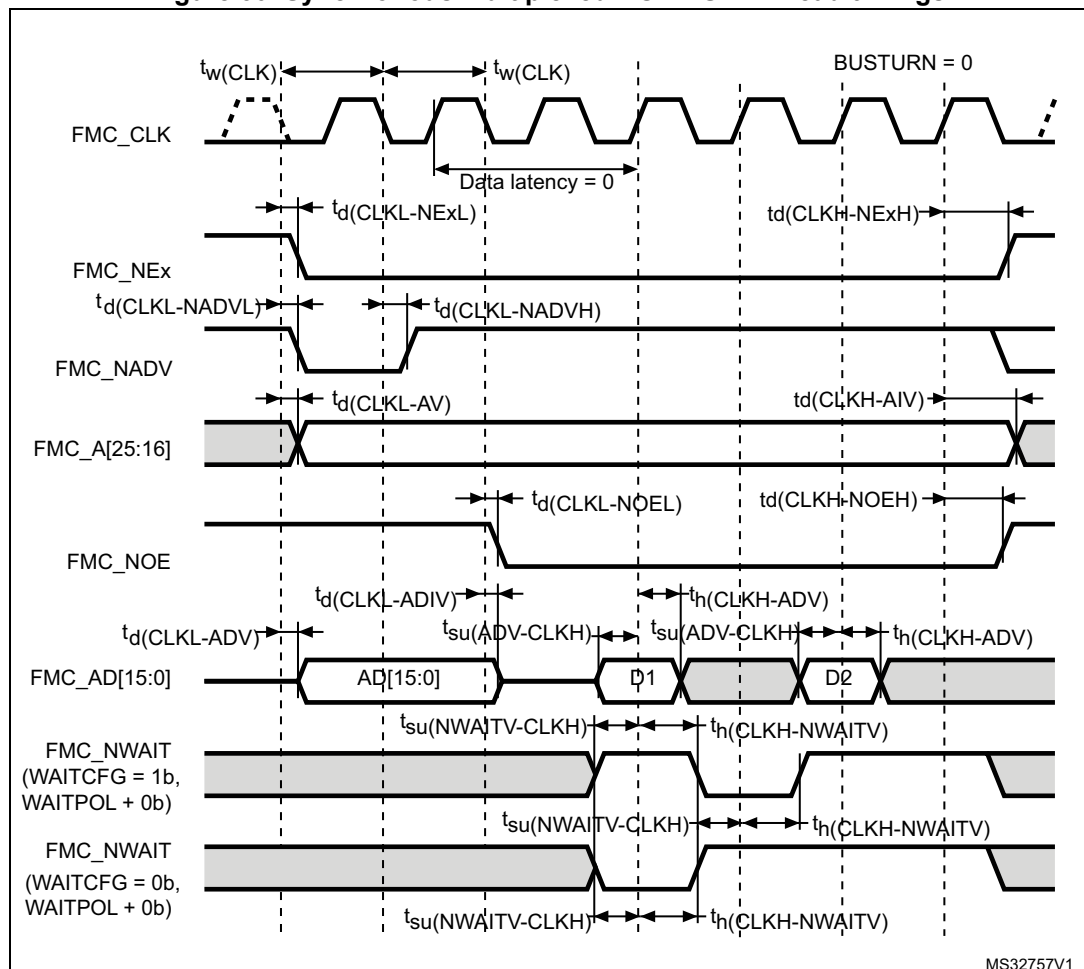

Prerelease product(s)

Table 76. Synchronous multiplexed NOR/PSRAM read timings⁽¹⁾

Symbol	Parameter	Min	Max	Unit
$t_{w(CLK)}$	FMC_CLK period	$2T_{fmc_ker_ck} - 0.5$	-	ns
$t_{d(CLKL-NExL)}$	FMC_CLK low to FMC_NEx low (x = 0..2)	-	1	
$t_{d(CLKH-NExH)}$	FMC_CLK high to FMC_NEx high (x = 0..2)	$T_{fmc_ker_ck} - 1$	-	
$t_{d(CLKL-NADV_L)}$	FMC_CLK low to FMC_NADV low	-	1.5	
$t_{d(CLKL-NADV_H)}$	FMC_CLK low to FMC_NADV high	0.5	-	
$t_{d(CLKL-AV)}$	FMC_CLK low to FMC_Ax valid (x = 16...25)	-	1	
$t_{d(CLKH-AIV)}$	FMC_CLK high to FMC_Ax invalid (x = 16...25)	$T_{fmc_ker_ck} - 1$	-	
$t_{d(CLKL-NOEL)}$	FMC_CLK low to FMC_NOE low	-	1	
$t_{d(CLKH-NOEH)}$	FMC_CLK high to FMC_NOE high	$T_{fmc_ker_ck} + 0.5$	-	
$t_{d(CLKL-ADV)}$	FMC_CLK low to FMC_AD[15:0] valid	-	3.5	
$t_{d(CLKL-ADIV)}$	FMC_CLK low to FMC_AD[15:0] invalid	0.5	-	
$t_{su(ADV-CLKH)}$	FMC_A/D[15:0] valid data before FMC_CLK high	3.5	-	
$t_h(CLKH-ADV)$	FMC_A/D[15:0] valid data after FMC_CLK high	1.5	-	
$t_{su(NWAIT-CLKH)}$	FMC_NWAIT valid before FMC_CLK high	2.5	-	
$t_h(CLKH-NWAIT)$	FMC_NWAIT valid after FMC_CLK high	1.5	-	

1. Evaluated by characterization - Not tested in production.

Prerelease product(s)

Figure 31. Synchronous multiplexed PSRAM write timings

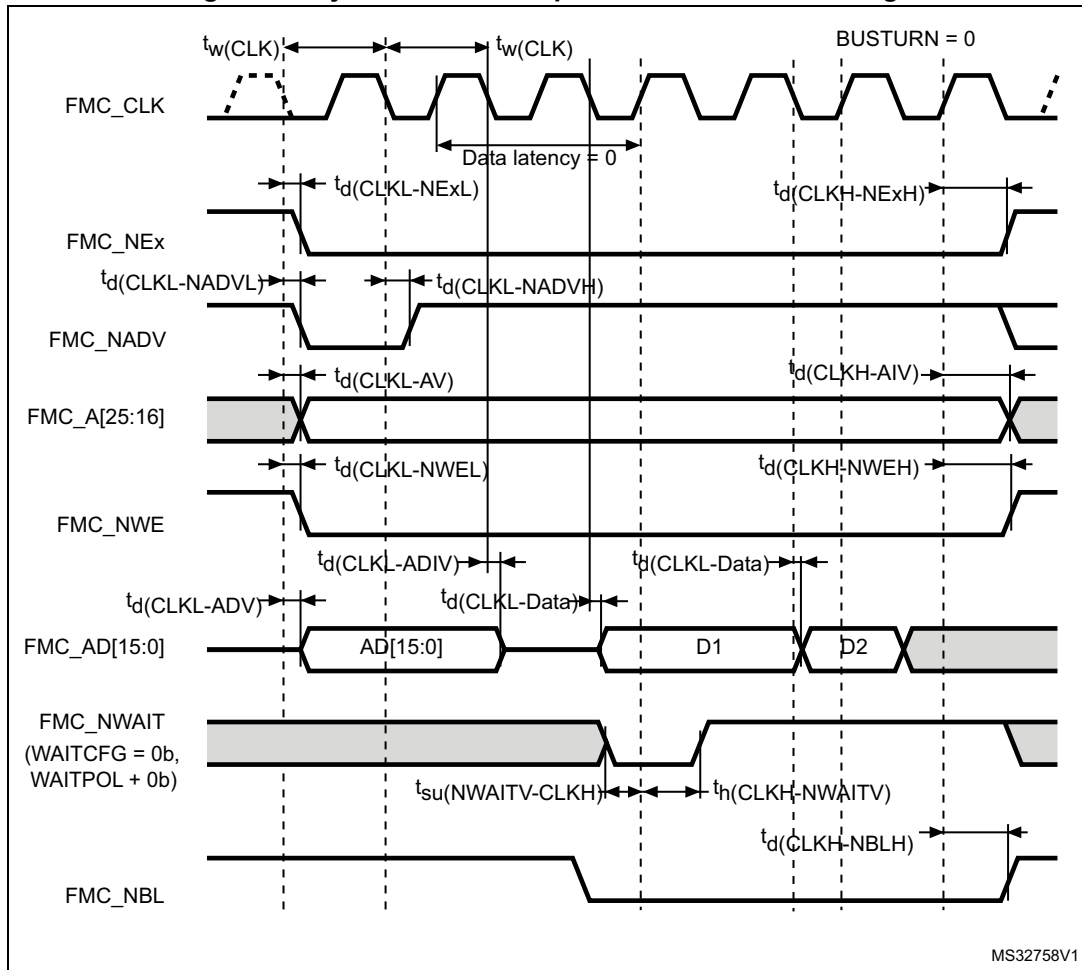

Prerelease product(s)

Table 77. Synchronous multiplexed PSRAM write timings⁽¹⁾

Symbol	Parameter	Min	Max	Unit
$t_{w(CLK)}$	FMC_CLK period, $V_{DD} = 2.7$ to 3.6 V	$2T_{fmc_ker_ck} - 0.5$	-	ns
$t_{d(CLKL-NExL)}$	FMC_CLK low to FMC_NEx low ($x = 0..2$)	-	1	
$t_{d(CLKH-NExH)}$	FMC_CLK high to FMC_NEx high ($x = 0..2$)	$T_{fmc_ker_ck} - 1$	-	
$t_{d(CLKL-NADVl)}$	FMC_CLK low to FMC_NADV low	-	1.5	
$t_{d(CLKL-NADVh)}$	FMC_CLK low to FMC_NADV high	0.5	-	
$t_{d(CLKL-AV)}$	FMC_CLK low to FMC_Ax valid ($x = 16..25$)	-	1	
$t_{d(CLKH-AIV)}$	FMC_CLK high to FMC_Ax invalid ($x = 16..25$)	$T_{fmc_ker_ck} - 1$	-	
$t_{d(CLKL-NWEL)}$	FMC_CLK low to FMC_NWE low	-	1	
$t_{d(CLKH-NWEH)}$	FMC_CLK high to FMC_NWE high	$T_{fmc_ker_ck} + 0.5$	-	
$t_{d(CLKL-ADV)}$	FMC_CLK low to FMC_AD[15:0] valid	-	3.5	
$t_{d(CLKL-ADIV)}$	FMC_CLK low to FMC_AD[15:0] invalid	1	-	
$t_{d(CLKL-DATA)}$	FMC_A/D[15:0] valid data after FMC_CLK low	-	1	
$t_{d(CLKL-NBLL)}$	FMC_CLK low to FMC_NBL low	-	1	
$t_{d(CLKH-NBLH)}$	FMC_CLK high to FMC_NBL high	$T_{fmc_ker_ck}$	-	
$t_{su(NWAIT-CLKH)}$	FMC_NWAIT valid before FMC_CLK high	2.5	-	
$t_h(CLKH-NWAIT)$	FMC_NWAIT valid after FMC_CLK high	1.5	-	

1. Evaluated by characterization - Not tested in production.

Prerelease product(s)

Figure 32. Synchronous non-multiplexed NOR/PSRAM read timings

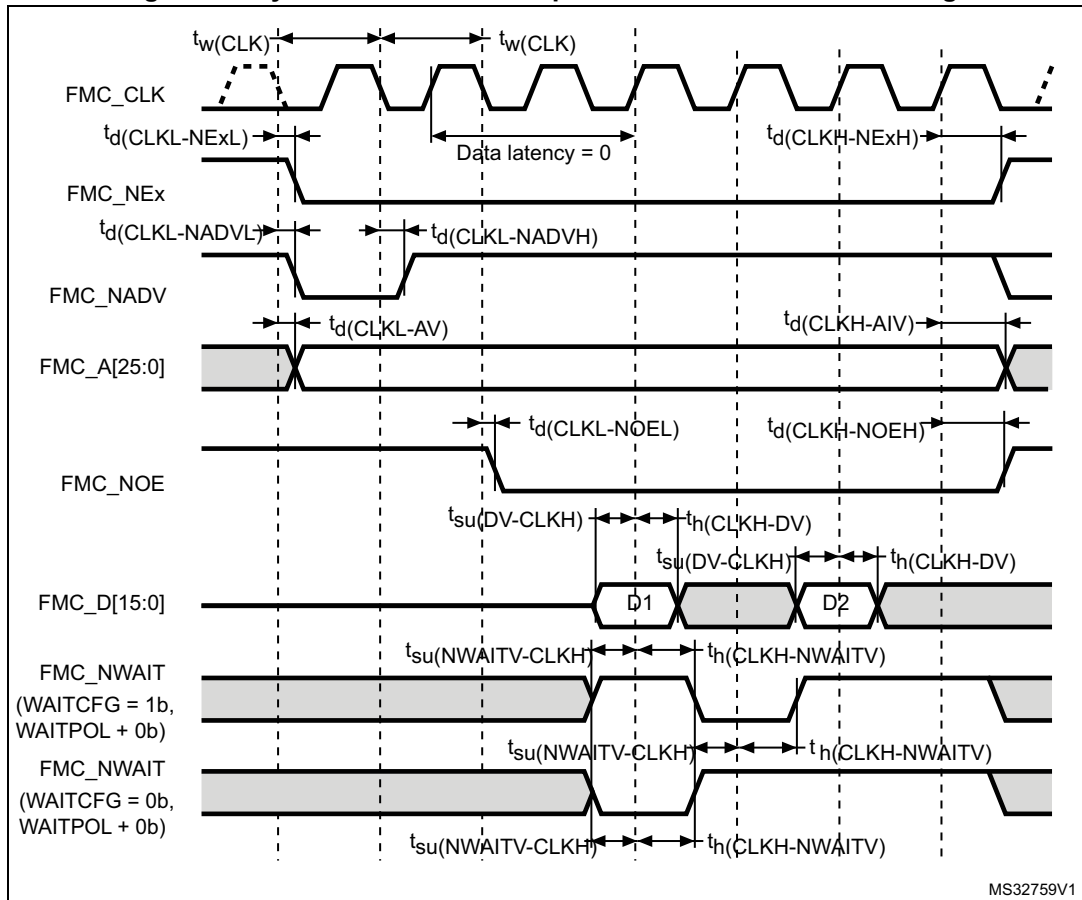

MS32759V1

Table 78. Synchronous non-multiplexed NOR/PSRAM read timings⁽¹⁾

Symbol	Parameter	Min	Max	Unit
$t_w(\text{CLK})$	FMC_CLK period	$2T_{\text{fmc_ker_ck}} - 0.5$	-	ns
$t_{\text{d}}(\text{CLKL-NExL})$	FMC_CLK low to FMC_NEx low (x = 0...2)	-	1	
$t_{\text{d}}(\text{CLKH-NExH})$	FMC_CLK high to FMC_NEx high (x = 0...2)	$T_{\text{fmc_ker_ck}} - 1$	-	
$t_{\text{d}}(\text{CLKL-NADVl})$	FMC_CLK low to FMC_NADV low	-	1.5	
$t_{\text{d}}(\text{CLKL-NADVh})$	FMC_CLK low to FMC_NADV high	0.5	-	
$t_{\text{d}}(\text{CLKL-AV})$	FMC_CLK low to FMC_Ax valid (x = 16...25)	-	1	
$t_{\text{d}}(\text{CLKH-AIV})$	FMC_CLK high to FMC_Ax invalid (x = 16...25)	$T_{\text{fmc_ker_ck}} - 1$	-	
$t_{\text{d}}(\text{CLKL-NOEL})$	FMC_CLK low to FMC_NOE low	-	1	
$t_{\text{d}}(\text{CLKH-NOEH})$	FMC_CLK high to FMC_NOE high	$T_{\text{fmc_ker_ck}} + 0.5$	-	
$t_{\text{su}}(\text{DV-CLKH})$	FMC_D[15:0] valid data before FMC_CLK high	3.5	-	
$t_{\text{h}}(\text{CLKH-DV})$	FMC_D[15:0] valid data after FMC_CLK high	1.5	-	
$t_{\text{su}}(\text{NWAITV-CLKH})$	FMC_NWAIT valid before FMC_CLK high	2.5	-	
$t_{\text{h}}(\text{CLKH-NWAITV})$	FMC_NWAIT valid after FMC_CLK high	1.5	-	

1. Evaluated by characterization - Not tested in production.

Prerelease product(s)

Figure 33. Synchronous non-multiplexed PSRAM write timings

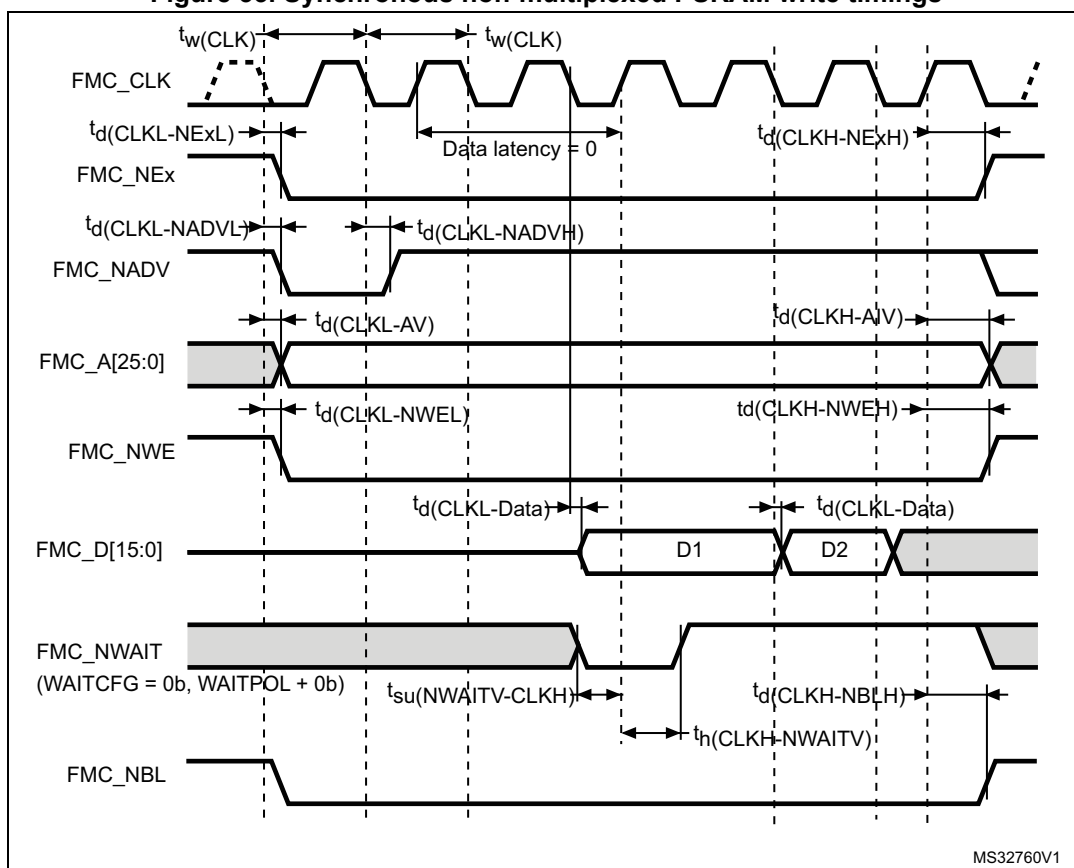

MS32760V1

Table 79. Synchronous non-multiplexed PSRAM write timings⁽¹⁾

Symbol	Parameter	Min	Max	Unit
$t_{(CLK)}$	FMC_CLK period	$2T_{fmc_ker_ck} - 0.5$	-	ns
$t_{d(CLKL-NExL)}$	FMC_CLK low to FMC_NEx low (x = 0...2)	-	1	
$t_{(CLKH-NExH)}$	FMC_CLK high to FMC_NEx high (x = 0...2)	$T_{fmc_ker_ck} - 0.5$	-	
$t_{d(CLKL-NADVl)}$	FMC_CLK low to FMC_NADV low	-	1.5	
$t_{d(CLKL-NADVh)}$	FMC_CLK low to FMC_NADV high	0.5	-	
$t_{d(CLKL-AV)}$	FMC_CLK low to FMC_Ax valid (x = 16...25)	-	1	
$t_{d(CLKH-AIV)}$	FMC_CLK high to FMC_Ax invalid (x = 16...25)	$T_{fmc_ker_ck} - 0.5$	-	
$t_{d(CLKL-NWEL)}$	FMC_CLK low to FMC_NWE low	-	1	
$t_{d(CLKH-NWEH)}$	FMC_CLK high to FMC_NWE high	$T_{fmc_ker_ck} + 0.5$	-	
$t_{d(CLKL-Data)}$	FMC_D[15:0] valid data after FMC_CLK low	-	3.5	
$t_{d(CLKL-NBLl)}$	FMC_CLK low to FMC_NBL low	-	1.5	
$t_{d(CLKH-NBLH)}$	FMC_CLK high to FMC_NBL high	$T_{fmc_ker_ck} - 0.5$	-	
$t_{su(NWAIT-CLKH)}$	FMC_NWAIT valid before FMC_CLK high	2.5	-	
$t_{h(CLKH-NWAIT)}$	FMC_NWAIT valid after FMC_CLK high	1.5	-	

Prerelease product(s)

1. Evaluated by characterization - Not tested in production.

NAND controller waveforms and timings

Figures 34 through 37 represent synchronous waveforms, tables 80 and 81 provide the corresponding timings. The results are obtained with the following FMC configuration and a capacitive load (C_L) of 30 pF:

- COM.FMC_SetupTime = 0x01
- COM.FMC_WaitSetupTime = 0x03
- COM.FMC_HoldSetupTime = 0x02
- COM.FMC_HiZSetupTime = 0x01
- ATT.FMC_SetupTime = 0x01
- ATT.FMC_WaitSetupTime = 0x03
- ATT.FMC_HoldSetupTime = 0x02
- ATT.FMC_HiZSetupTime = 0x01
- Bank = FMC_Bank_NAND
- MemoryDataWidth = FMC_MemoryDataWidth_16b
- ECC = FMC_ECC_Enable
- ECCPageSize = FMC_ECCPageSize_512Bytes
- TCLRSetupTime = 0
- TARSetupTime = 0
- Capacitive load $C_L = 30$ pF

In all timing tables, $T_{fmc_ker_ck}$ is the HCLK clock period.

Figure 34. NAND controller waveforms for read access

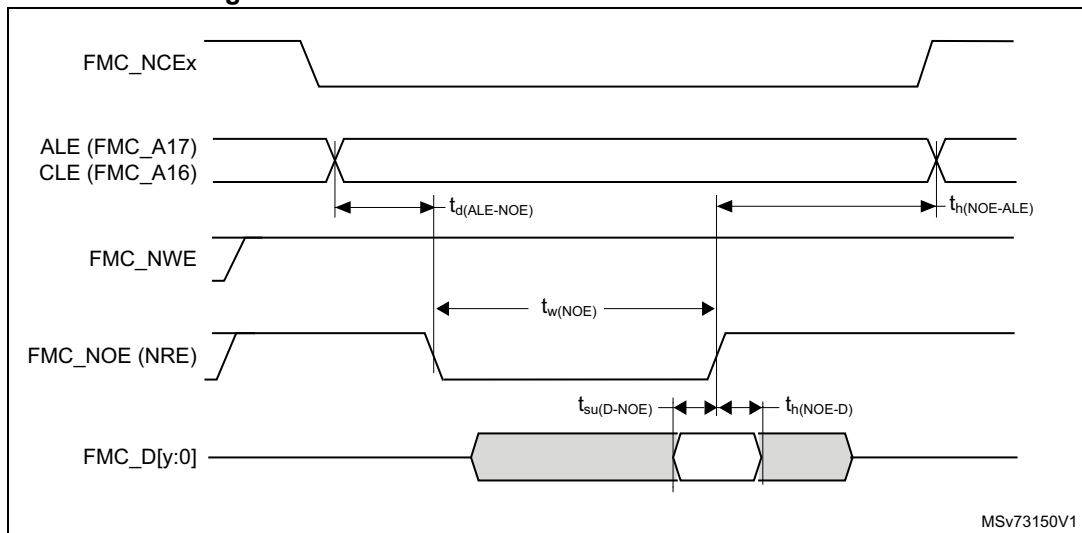

1. $y = 7$ or 15 , depending upon the NAND flash memory interface.

Prerelease product(s)

Figure 35. NAND controller waveforms for write access

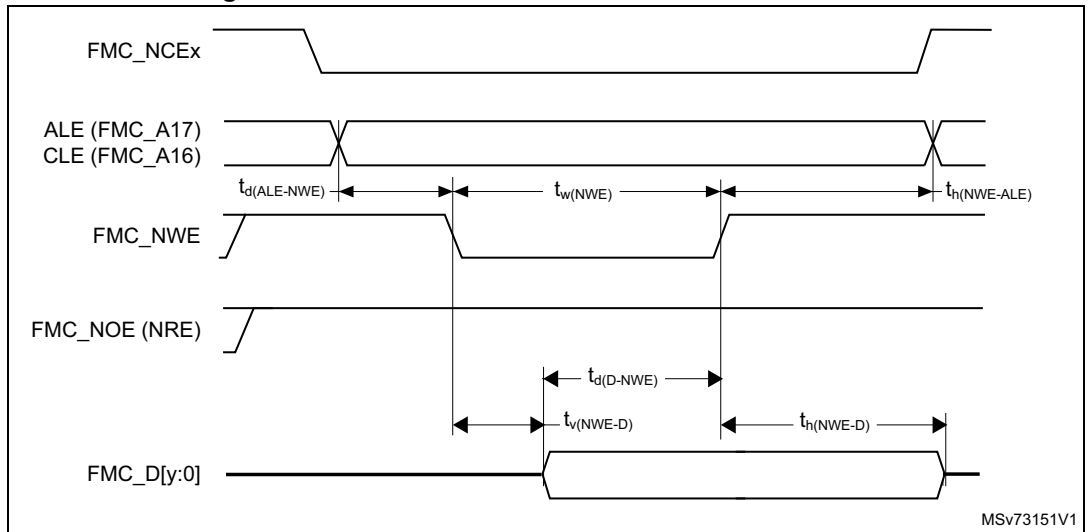

1. $y = 7$ or 15 , depending upon the NAND flash memory interface.

Figure 36. NAND controller waveforms for common memory read access

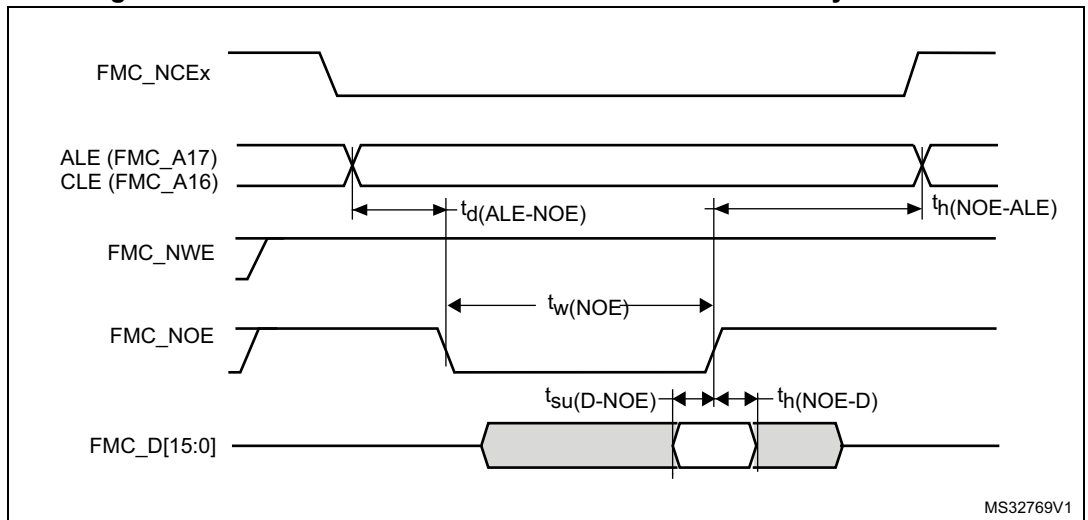

Prerelease product(s)

Figure 37. NAND controller waveforms for common memory write access

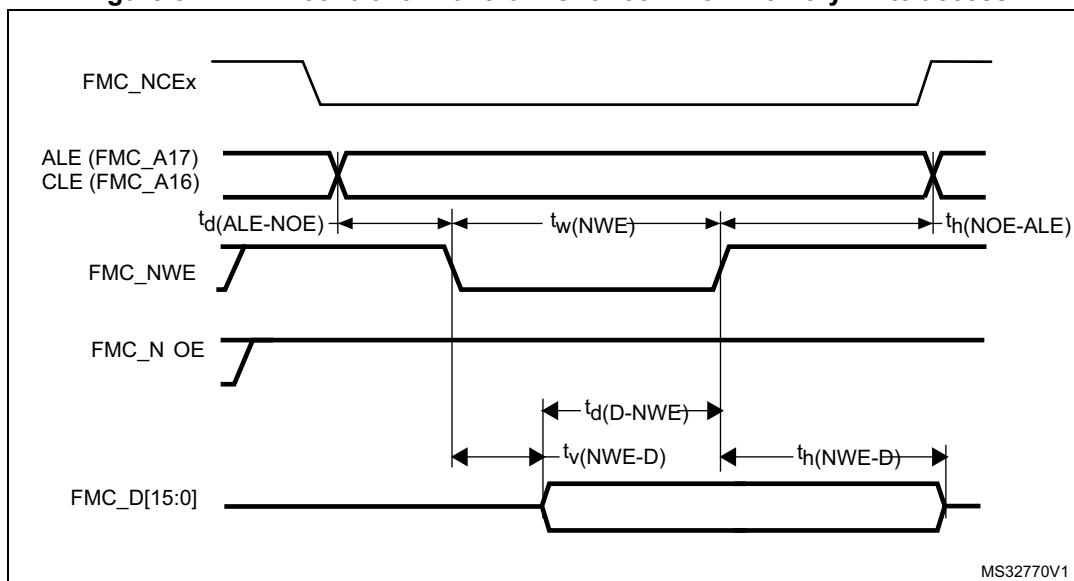

Table 80. Switching characteristics for NAND flash read cycles⁽¹⁾

Symbol	Parameter	Min	Max	Unit
$t_{w(NOE)}$	FMC_NOE low width	$4T_{fmc_ker_ck} - 0.5$	$4T_{fmc_ker_ck} + 0.5$	ns
$t_{su(D-NOE)}$	FMC_D[15-0] valid data before FMC_NOE high	11	-	
$t_{h(NOE-D)}$	FMC_D[15-0] valid data after FMC_NOE high	0	-	
$t_d(ALE-NOE)$	FMC_ALE valid before FMC_NOE low	-	$3T_{fmc_ker_ck} + 0.5$	
$t_{h(NOE-ALE)}$	FMC_NWE high to FMC_ALE invalid	$4T_{fmc_ker_ck} - 1.5$	-	

1. Evaluated by characterization - Not tested in production.

Table 81. Switching characteristics for NAND flash write cycles⁽¹⁾

Symbol	Parameter	Min	Max	Unit
$t_{w(NWE)}$	FMC_NWE low width	$4T_{fmc_ker_ck} - 0.5$	$4T_{fmc_ker_ck} + 0.5$	ns
$t_v(NWE-D)$	FMC_NWE low to FMC_D[15-0] valid	0	-	
$t_h(NWE-D)$	FMC_NWE high to FMC_D[15-0] invalid	$2T_{fmc_ker_ck} + 0.5$	-	
$t_d(D-NWE)$	FMC_D[15-0] valid before FMC_NWE high	$5T_{fmc_ker_ck} - 2.5$	-	
$t_d(ALE-NWE)$	FMC_ALE valid before FMC_NWE low	-	$3T_{fmc_ker_ck} + 0.5$	
$t_h(NWE-ALE)$	FMC_NWE high to FMC_ALE invalid	$2T_{fmc_ker_ck} - 1$	-	

1. Evaluated by characterization - Not tested in production.

SDRAM waveforms and timings

In all timing tables, the $t_{fmc_ker_ck}$ is the f_{HCLK} clock period, with the following FMC_SDCLK maximum values:

- For $2.7\text{ V} < V_{DD} < 3.6\text{ V}$: maximum FMC_SDCLK = 95 MHz at 20 pF (100 MHz for $V_{DD} > 3.0\text{ V}$)
- For $1.71\text{ V} < V_{DD} < 1.8\text{ V}$: maximum FMC_SDCLK = 95 MHz at 15 pF
- For $1.71\text{ V} < V_{DD} < 1.8\text{ V}$: maximum FMC_SDCLK = 90 MHz at 20 pF

Figure 38. SDRAM read access waveforms (CL = 1)

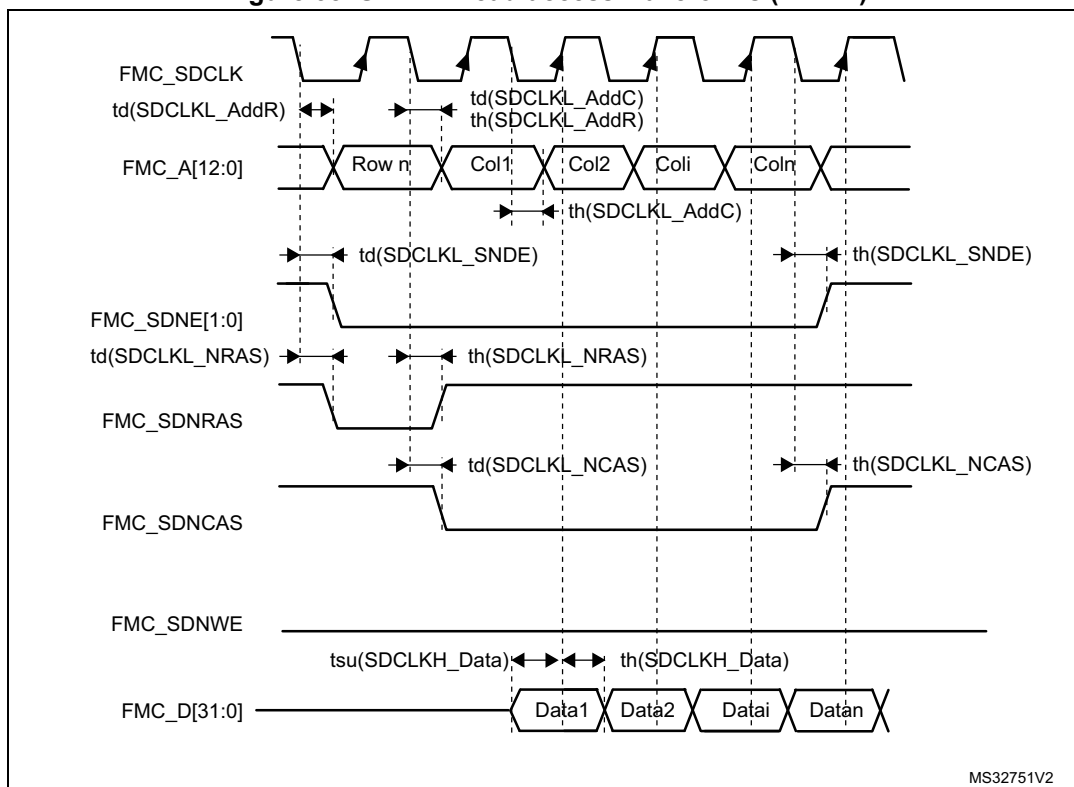

MS32751V2

Table 82. SDRAM read timings⁽¹⁾

Symbol	Parameter	Min	Max	Unit
$t_w(\text{SDCLK})$	FMC_SDCLK period	$2T_{fmc_ker_ck} - 0.5$	$2T_{fmc_ker_ck} + 0.5$	ns
$t_{su}(\text{SDCLKH_Data})$	Data input setup time	3	-	
$t_h(\text{SDCLKH_Data})$	Data input hold time	0.5	-	
$t_d(\text{SDCLKL_Add})$	Address valid time	-	1.5	
$t_d(\text{SDCLKL-SDNE})$	Chip select valid time	-	1.5	
$t_h(\text{SDCLKL_SDNE})$	Chip select hold time	0	-	
$t_d(\text{SDCLKL_SDNRAS})$	SDNRAS valid time	-	1.5	
$t_h(\text{SDCLKL_SDNRAS})$	SDNRAS hold time	0	-	
$t_d(\text{SDCLKL_SDNCAS})$	SDNCAS valid time	-	1	
$t_h(\text{SDCLKL_SDNCAS})$	SDNCAS hold time	0	-	

1. Evaluated by characterization - Not tested in production.

Table 83. LPSDR SDRAM read timings⁽¹⁾

Symbol	Parameter	Min	Max	Unit
$t_{W(SDCLK)}$	FMC_SDCLK period	$2T_{fmc_ker_ck} - 0.5$	$2T_{fmc_ker_ck} + 0.5$	ns
$t_{su(SDCLKH_Data)}$	Data input setup time	3	-	
$t_{h(SDCLKH_Data)}$	Data input hold time	0.5	-	
$t_{d(SDCLKL_Add)}$	Address valid time	-	1.5	
$t_{d(SDCLKL_SDNE)}$	Chip select valid time	-	1.5	
$t_{h(SDCLKL_SDNE)}$	Chip select hold time	0	-	
$t_{d(SDCLKL_SDNRAS)}$	SDNRAS valid time	-	1.5	
$t_{h(SDCLKL_SDNRAS)}$	SDNRAS hold time	0	-	
$t_{d(SDCLKL_SDNCAS)}$	SDNCAS valid time	-	1	
$t_{h(SDCLKL_SDNCAS)}$	SDNCAS hold time	0	-	

1. Evaluated by characterization - Not tested in production.

Figure 39. SDRAM write access waveforms

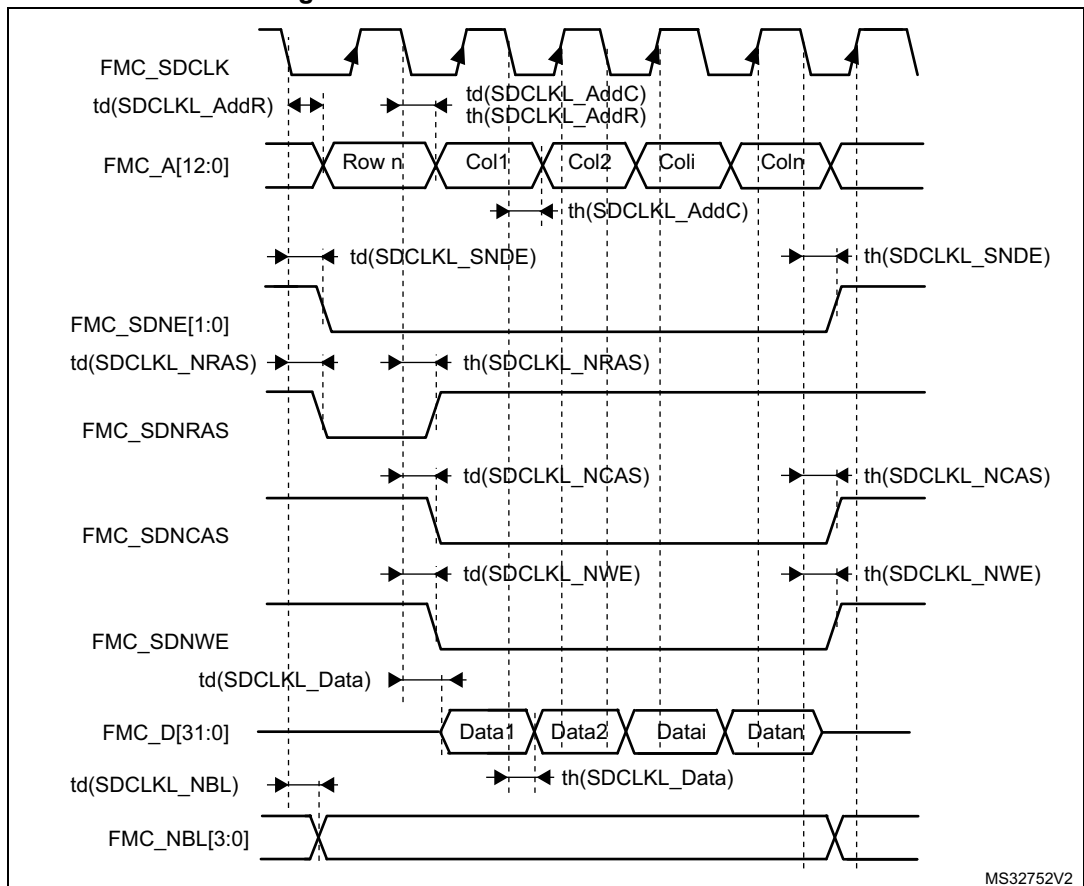

MS32752V2

Prerelease product(s)

Table 84. SDRAM write timings⁽¹⁾

Symbol	Parameter	Min	Max	Unit
$t_w(\text{SDCLK})$	FMC_SDCLK period	$2T_{\text{fmc_ker_ck}} - 0.5$	$2T_{\text{fmc_ker_ck}} + 0.5$	ns
$t_d(\text{SDCLKL_Data})$	Data output valid time	-	1	
$t_h(\text{SDCLKL_Data})$	Data output hold time	0	-	
$t_d(\text{SDCLKL_Add})$	Address valid time	-	2	
$t_d(\text{SDCLKL_SDNWE})$	SDNWE valid time	-	1	
$t_h(\text{SDCLKL_SDNWE})$	SDNWE hold time	0	-	
$t_d(\text{SDCLKL_SDNE})$	Chip select valid time	-	1.5	
$t_h(\text{SDCLKL_SDNE})$	Chip select hold time	0	-	
$t_d(\text{SDCLKL_SDNRAS})$	SDNRAS valid time	-	1.5	
$t_h(\text{SDCLKL_SDNRAS})$	SDNRAS hold time	0	-	
$t_d(\text{SDCLKL_SDNCAS})$	SDNCAS valid time	-	1	
$t_d(\text{SDCLKL_SDNCAS})$	SDNCAS hold time	0	-	

1. Evaluated by characterization - Not tested in production.

Table 85. LPSDR SDRAM write timings⁽¹⁾

Symbol	Parameter	Min	Max	Unit
$t_w(\text{SDCLK})$	FMC_SDCLK period	$2T_{\text{fmc_ker_ck}} - 0.5$	$2T_{\text{fmc_ker_ck}} + 0.5$	ns
$t_d(\text{SDCLKL_Data})$	Data output valid time	-	1	
$t_h(\text{SDCLKL_Data})$	Data output hold time	0	-	
$t_d(\text{SDCLKL_Add})$	Address valid time	-	2	
$t_d(\text{SDCLKL-SDNWE})$	SDNWE valid time	-	1	
$t_h(\text{SDCLKL-SDNWE})$	SDNWE hold time	0	-	
$t_d(\text{SDCLKL-SDNE})$	Chip select valid time	-	1.5	
$t_h(\text{SDCLKL-SDNE})$	Chip select hold time	0	-	
$t_d(\text{SDCLKL-SDNRAS})$	SDNRAS valid time	-	1.5	
$t_h(\text{SDCLKL-SDNRAS})$	SDNRAS hold time	0	-	
$t_d(\text{SDCLKL-SDNCAS})$	SDNCAS valid time	-	1	
$t_d(\text{SDCLKL-SDNCAS})$	SDNCAS hold time	0	-	

1. Evaluated by characterization - Not tested in production.

Prerelease product(s)

5.3.19 Octo-SPI interface characteristics

Unless otherwise specified, the parameters given in [Table 86](#) and [Table 87](#) are derived from tests performed under the ambient temperature, f_{HCLK} frequency, and V_{DD} supply voltage conditions summarized in [Table 17](#), with the following configuration:

- Output speed is set to $OSPEEDRy[1:0] = 11$
- Measurement points are done at CMOS levels: $0.5 V_{DD}$
- I/O compensation cell activated
- HSLV activated when $V_{DD} \leq 2.7 V$
- VOS level set to VOS0

Refer to [Section 5.3.14](#) for more details on the input/output alternate function characteristics.

Table 86. OCTOSPI characteristics in SDR mode⁽¹⁾⁽²⁾

Symbol	Parameter	Conditions	Min	Typ	Max ⁽³⁾	Unit
$F_{(CLK)}$	Clock frequency	$1.71 V < V_{DD} < 3.6 V$, $C_L = 15 pF$	-	-	110	MHz
		$2.71 V < V_{DD} < 3.6 V$, $C_L = 15 pF$	-	-	150	
$t_{w(CLKH)}$	Clock high and low time, even division	PRESCALER[7:0] = n (= 0, 1, 3, 5, ..., 255)	$t_{(CLK)} / 2 - 0.5$	-	$t_{(CLK)} / 2 + 0.5$	ns
$t_{w(CLKL)}$			$t_{(CLK)} / 2 - 0.5$	-	$t_{(CLK)} / 2 + 0.5$	
$t_{w(CLKH)}$	Clock high and low time, odd division	PRESCALER[7:0] = n (= 2, 4, 6, ..., 254)	$(n / 2) * t_{(CLK)} / (n + 1) - 0.5$	-	$(n / 2) * t_{(CLK)} / (n + 1) + 0.5$	
$t_{w(CLKL)}$			$(n / 2 + 1) * t_{(CLK)} / (n + 1) - 0.5$	-	$(n / 2 + 1) * t_{(CLK)} / (n + 1) + 0.5$	
$t_{s(IN)}$	Data input setup time	-	4	-	-	
$t_{h(IN)}$	Data input hold time	-	1	-	-	
$t_{v(OUT)}$	Data output valid time	-	-	1	1.5	
$t_{h(OUT)}$	Data output hold time	-	0	-	-	

1. All values apply to Octal- and Quad-SPI mode.
2. Evaluated by characterization - Not tested in production.
3. At VOS1 these values are degraded by up to 5%.

Figure 40. OCTOSPI SDR read/write timing diagram

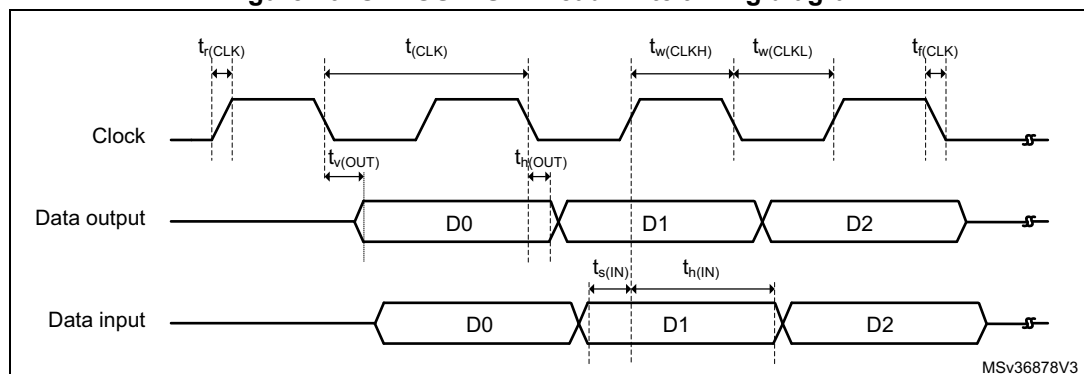

Prerelease product(s)

Table 87. OCTOSPI characteristics in DTR mode (no DQS)⁽¹⁾⁽²⁾⁽³⁾

Symbol	Parameter	Conditions	Min	Typ	Max	Unit
F _{CLK}	OCTOSPI clock frequency	1.71 V < V _{DD} < 3.6 V, C _L = 15 pF	-	-	100 ⁽⁴⁾	MHz
		2.7 V < V _{DD} < 3.6 V, C _L = 15 pF	-	-	125 ⁽⁴⁾	
t _{w(CLKH)}	OCTOSPI clock high and low time	PRESCALER[7:0] = n (= 0, 1, 3, 5, ..., 255)	t _(CLK) / 2 - 0.5	-	t _(CLK) / 2 + 0.5	ns
t _{w(CLKL)}			t _(CLK) / 2 - 0.5	-	t _(CLK) / 2 + 0.5	
t _{w(CLKH)}	OCTOSPI clock high and low time	PRESCALER[7:0] = n (= 2, 4, 6, 8, ..., 254)	(n / 2) * t _(CLK) / (n + 1) - 0.5	-	(n / 2) * t _(CLK) / (n + 1) + 0.5	ns
t _{w(CLKL)}			(n / 2 + 1) * t _(CLK) / (n + 1) - 0.5	-	(n / 2 + 1) * t _(CLK) / (n + 1) + 0.5	
t _{sr(IN)} , t _{sf(IN)}	Data input setup time	-	4	-	-	ns
t _{hr(IN)} , t _{hf(IN)}	Data input hold time	-	1.5	-	-	
t _{vr(OUT)} , t _{vf(OUT)}	Data output valid time	DHQC = 0	-	-	-	ns
		DHQC = 1, Prescaler [7:0] = 1, 2...	-	t _(CLK) / 4 + 0.5	t _(CLK) / 4 + 1	
t _{hr(OUT)} , t _{hf(OUT)}	Data output hold time	DHQC = 0	1.5	-	-	ns
		DHQC = 1, Prescaler [7:0] = 1, 2...	t _(CLK) / 4 - 1	-	-	
t _{vr(OUT)} , t _{vf(OUT)}	Data output valid time	DHQC = 0	-	3.5	4	ns
		DHQC = 1, All prescaler values except 0	-	t _(CLK) / 4 + 1	t _(CLK) / 4 + 1.5	
t _{hr(OUT)} , t _{hf(OUT)}	Data output hold time	DHQC = 0	1.5	-	-	ns
		DHQC = 1, All prescaler values except 0	t _(CLK) / 4 - 1	-	-	

1. All values apply to Octal and Quad-SPI mode.
2. Evaluated by characterization - Not tested in production.
3. Delay block bypassed.
4. DHQC must be set to reach the mentioned frequency.

Prerelease product(s)

Table 88. OCTOSPI characteristics in DTR mode (with DQS) / HyperBus⁽¹⁾⁽²⁾

Symbol	Parameter	Conditions	Min	Typ	Max	Unit
F _{CLK}	OCTOSPI clock frequency	1.71 V < V _{DD} < 3.6 V, C _L = 15 pF	-	-	125 ⁽³⁾⁽⁴⁾	MHz
		2.7 V < V _{DD} < 3.6 V, C _L = 15 pF	-	-	125 ⁽³⁾⁽⁴⁾	
t _{w(CLKH)}	OCTOSPI clock high and low time	PRESCALER[7:0] = n = (0, 1, 3, 5, ..., 255)	t _{(CLK)/2} - 0.5	-	t _{(CLK)/2} + 0.5	ns
t _{w(CLKL)}			t _{(CLK)/2} - 0.5	-	t _{(CLK)/2} + 0.5	
t _{w(CLKH)}	OCTOSPI clock high and low time	PRESCALER[7:0] = n = (2, 4, 6, 8, ..., 254)	(n/2)*t _{(CLK)/} (n+1) - 0.5	-	(n/2)*t _{(CLK)/} (n+1) + 0.5	ns
t _{w(CLKL)}			(n/2+1)*t _{(CLK)/} (n+1) - 0.5	-	(n/2+1)*t _{(CLK)/} (n+1) + 0.5	
t _{v(CLK)}	Clock valid time	-	-	-	t _(CLK) + 2	
t _{h(CLK)}	Clock hold time	-	t _{(CLK)/2} - 1	-	-	
t _{ODr(CLK)} ⁽⁵⁾	CLK, NCLK crossing level on CLK rising edge	V _{DD} = 1.8 V	1000	-	1080	mV
t _{ODf(CLK)} ⁽⁵⁾	CLK, NCLK crossing level on CLK falling edge	V _{DD} = 1.8 V	930	-	1040	mV
t _{w(CS)}	Chip select high time	-	3 * t _(CLK)	-	-	ns
t _{v(DQ)}	Data input valid time	-	3	-	-	
t _{v(DS)}	Data strobe input valid time	-	1	-	-	
t _{h(DS)}	Data strobe input hold time	-	0	-	-	
t _{v(RWDS)}	Data strobe output valid time	-	-	-	3 * t _(CLK)	
t _{sr(DQ),} t _{sf(DQ)}	Data input setup time	-	-0.25	-	-	ns
t _{hr(DQ),} t _{hf(DQ)}	Data input hold time	-	3.5	-	-	
t _{vr(OUT)} t _{vf(OUT)}	Data output valid time	DHQC = 0	-	3	4	
		DHQC = 1, all prescaler values except 0	-	t _{(CLK)/4} + 0.5	t _{(CLK)/4} + 1	
t _{hr(OUT)} t _{hf(OUT)}	Data output hold time	DHQC = 0	1.5	-	-	
		DHQC = 1, all prescaler values except 0	t _{(CLK)/4} - 1	-	-	

1. Evaluated by characterization - Not tested in production.
2. Delay block activated.
3. Maximum frequency value are given for a maximum RWDS to DQ skew of ± 1.0 ns.
4. DHQC must be set to reach the mentioned frequency.
5. PA3/PB12 and PF10/PB5 must comply with the crossing specification.

Prerelease product(s)

Figure 41. OCTOSPI timing diagram - DTR mode

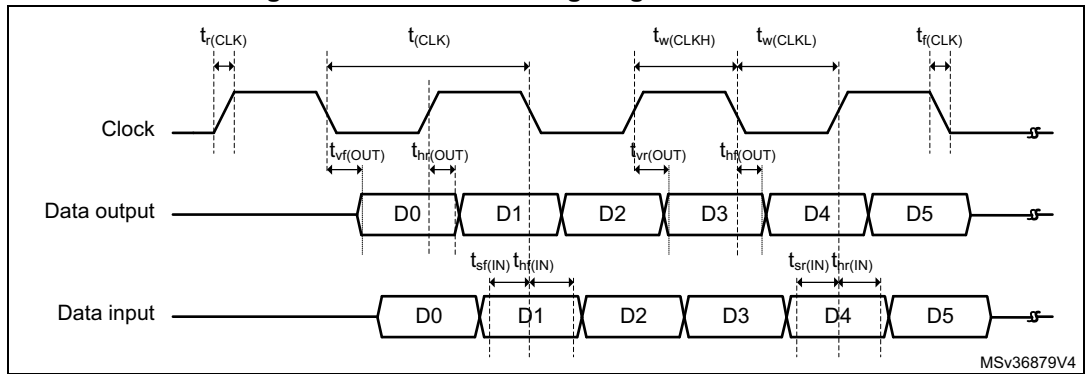

Figure 42. OCTOSPI HyperBus clock

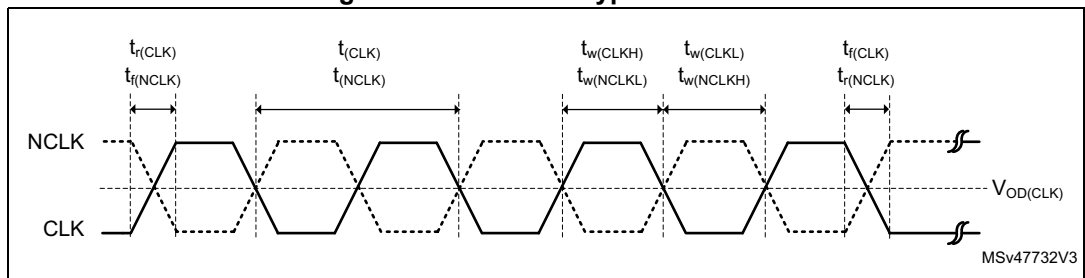
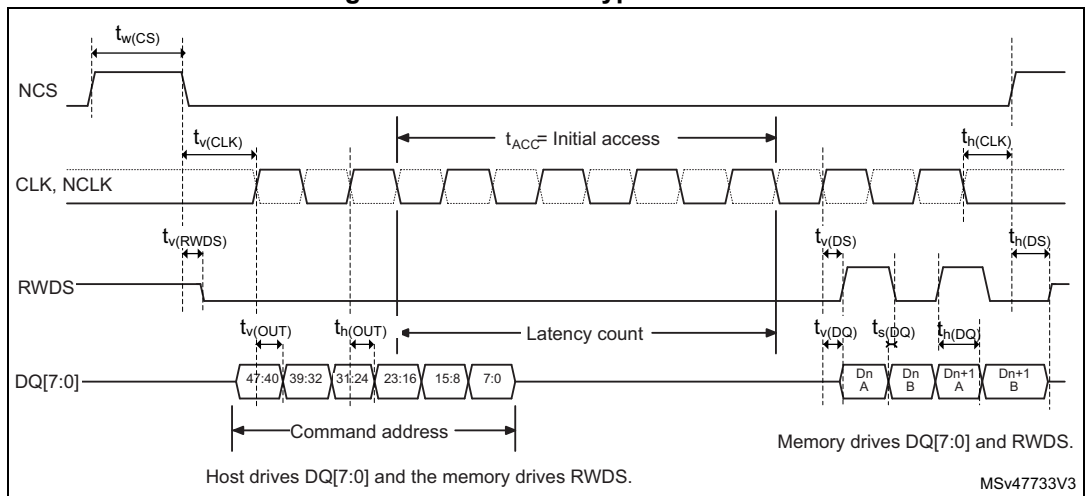
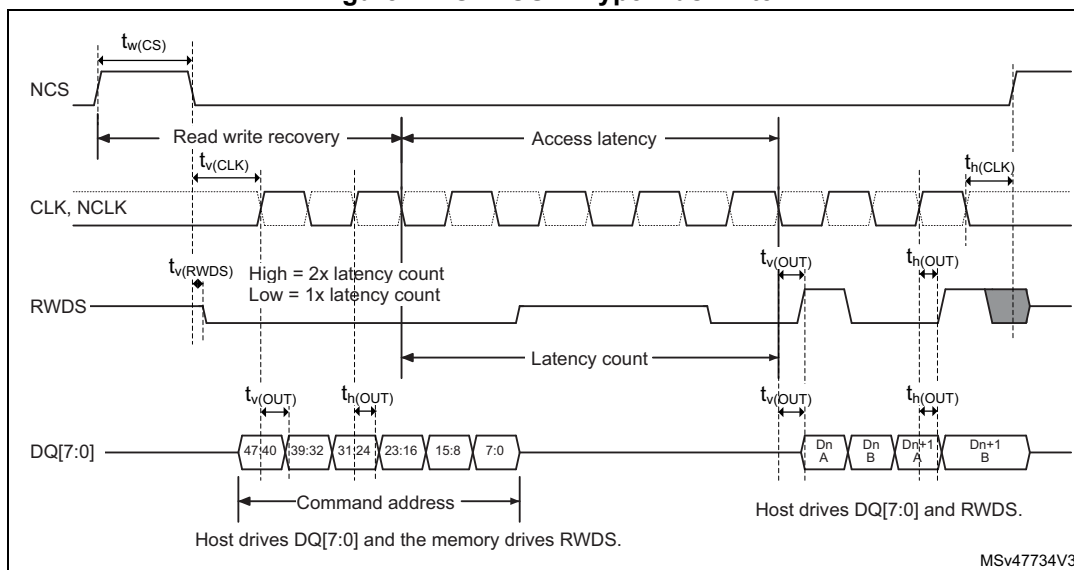

Figure 43. OCTOSPI HyperBus read



Prerelease product(s)

Figure 44. OCTOSPI HyperBus write



5.3.20 Delay block (DLYB) characteristics

Unless otherwise specified, the parameters given in [Table 89](#) are derived from tests performed under the ambient temperature, f_{HCLK} frequency, and V_{DD} supply voltage summarized in [Table 17](#).

Table 89. Delay block characteristics⁽¹⁾

Symbol	Parameter	Conditions	Min	Typ	Max	Unit
t_{init}	Initial delay	-	750	1100	1700	ps
t_{Δ}	Unit delay	-	38	44	54	ps

1. Evaluated by characterization - Not tested in production.

5.3.21 12-bit ADC characteristics

Unless otherwise specified, the parameters given in [Table 90](#) are derived from tests performed under the ambient temperature, f_{HCLK} frequency, and V_{DDA} supply voltage conditions summarized in [Table 17](#).

Table 90. 12-bit ADC characteristics⁽¹⁾⁽²⁾

Symbol	Parameter	Conditions	Min	Typ	Max	Unit
V_{DDA}	Analog supply voltage for ADC ON	-	1.62	-	3.6	V
$V_{\text{REF+}}$	Positive reference voltage	-	1.62	-	V_{DDA}	
$V_{\text{REF-}}$	Negative reference voltage	-	V_{SSA}			

Table 90. 12-bit ADC characteristics⁽¹⁾⁽²⁾ (continued)

Symbol	Parameter	Conditions				Min	Typ	Max	Unit		
$f_{\text{adc_ker_ck}}^{(3)}$	Clock frequency	$1.62 \text{ V} \leq V_{\text{DDA}} \leq 3.6 \text{ V}$				1.5	-	75	MHz		
$f_s^{(4)}$ with $R_{\text{AIN}} = 47 \text{ } \Omega$ and $C_{\text{PCB}} = 22 \text{ pF}$	Sampling rate for fast channels (VIN[0:5])	Resolution = 12 bits	Continuous mode	$1.8 \text{ V} \leq V_{\text{DDA}} \leq 3.6 \text{ V}$	$-40^\circ\text{C} \leq T_J \leq 130^\circ\text{C}$	$f_{\text{adc_ker_ck}} = 75 \text{ MHz}$	SM P=2 .5	-	5.00	-	MSPS
				$1.6 \text{ V} \leq V_{\text{DDA}} \leq 3.6 \text{ V}$		$f_{\text{adc_ker_ck}} = 70 \text{ MHz}$		-	4.66	-	
			Single or Discontinuous mode	$2.4 \text{ V} \leq V_{\text{DDA}} \leq 3.6 \text{ V}$		$f_{\text{adc_ker_ck}} = 60 \text{ MHz}$		-	4.00	-	
				$1.6 \text{ V} \leq V_{\text{DDA}} \leq 3.6 \text{ V}$		$f_{\text{adc_ker_ck}} = 50 \text{ MHz}$		-	3.33	-	
		Resolution = 10 bits	Continuous mode	$1.6 \text{ V} \leq V_{\text{DDA}} \leq 3.6 \text{ V}$		$f_{\text{adc_ker_ck}} = 75 \text{ MHz}$		-	5.77	-	
				$2.4 \text{ V} \leq V_{\text{DDA}} \leq 3.6 \text{ V}$		$f_{\text{adc_ker_ck}} = 75 \text{ MHz}$		-	5.77	-	
			Single or Discontinuous mode	$1.6 \text{ V} \leq V_{\text{DDA}} \leq 3.6 \text{ V}$		$f_{\text{adc_ker_ck}} = 65 \text{ MHz}$		-	5.00	-	
				All modes		$1.6 \text{ V} \leq V_{\text{DDA}} \leq 3.6 \text{ V}$		$f_{\text{adc_ker_ck}} = 75 \text{ MHz}$	-	6.82	
	$f_{\text{adc_ker_ck}} = 75 \text{ MHz}$	-	8.33		-						
	Resolution = 8 bits	All modes ⁽⁵⁾	$1.6 \text{ V} \leq V_{\text{DDA}} \leq 3.6 \text{ V}$	$f_{\text{adc_ker_ck}} = 35 \text{ MHz}$	-	2.30	-				
				$f_{\text{adc_ker_ck}} = 50 \text{ MHz}$	-	2.70	-				
				$f_{\text{adc_ker_ck}} = 50 \text{ MHz}$	-	4.50	-				
				$f_{\text{adc_ker_ck}} = 50 \text{ MHz}$	-	5.50	-				
	Resolution = 6 bits	All modes ⁽⁵⁾	$1.6 \text{ V} \leq V_{\text{DDA}} \leq 3.6 \text{ V}$	$f_{\text{adc_ker_ck}} = 35 \text{ MHz}$	-	2.30	-				
				$f_{\text{adc_ker_ck}} = 50 \text{ MHz}$	-	2.70	-				
				$f_{\text{adc_ker_ck}} = 50 \text{ MHz}$	-	4.50	-				
$f_{\text{adc_ker_ck}} = 50 \text{ MHz}$				-	5.50	-					
Sampling rate for slow channels	All modes ⁽⁵⁾	$1.6 \text{ V} \leq V_{\text{DDA}} \leq 3.6 \text{ V}$	$f_{\text{adc_ker_ck}} = 35 \text{ MHz}$	-	2.30	-					
			$f_{\text{adc_ker_ck}} = 50 \text{ MHz}$	-	2.70	-					
			$f_{\text{adc_ker_ck}} = 50 \text{ MHz}$	-	4.50	-					
			$f_{\text{adc_ker_ck}} = 50 \text{ MHz}$	-	5.50	-					
t_{TRIG}	External trigger period	Resolution = 12 bits				-	-	15	$1/f_{\text{adc_ker_ck}}$		
$V_{\text{AIN}}^{(2)}$	Conversion voltage range	-				0	-	$V_{\text{REF+}}$	V		
V_{CMIV}	Common mode input voltage	-				$V_{\text{REF}} / 2 - 10\%$	$V_{\text{REF}} / 2$	$V_{\text{REF}} / 2 + 10\%$			

Prerelease product(s)

Table 90. 12-bit ADC characteristics⁽¹⁾⁽²⁾ (continued)

Symbol	Parameter	Conditions	Min	Typ	Max	Unit
R _{AIN} ⁽⁶⁾	External input impedance	Resolution = 12 bits, T _J = 130°C (tolerance 4 LSBs)	-	-	321	Ω
		Resolution = 12 bits, T _J = 125°C	-	-	220	
		Resolution = 10 bits, T _J = 130°C	-	-	1039	
		Resolution = 10 bits, T _J = 125°C	-	-	2100	
		Resolution = 8 bits, T _J = 130°C	-	-	6327	
		Resolution = 8 bits, T _J = 125°C	-	-	12000	
		Resolution = 6 bits, T _J = 130°C	-	-	47620	
C _{ADC}	Internal sample and hold capacitor	-	-	3	-	pF
t _{ADCVREG_STUP}	LDO startup time	-	-	5	10	μs
t _{STAB}	Power-up time	LDO already started	1	-	-	Conversion cycle
t _{OFF_CAL}	Offset calibration time	-	1335			1/f _{adc_ker_ck}
t _{LATR}	Trigger conversion latency for regular and injected channels without aborting the conversion	CKMODE = 00	1.5	2	2.5	
		CKMODE = 01	-	-	2.5	
		CKMODE = 10	-	-	2.5	
		CKMODE = 11	-	-	2.25	
t _{LATRINJ}	Trigger conversion latency for regular and injected channels when a regular conversion is aborted	CKMODE = 00	2.5	3	3.5	
		CKMODE = 01	-	-	3.5	
		CKMODE = 10	-	-	3.5	
		CKMODE = 11	-	-	3.25	
t _S	Sampling time	-	2.5	-	640.5	
t _{CONV}	Total conversion time (including sampling)	N-bits resolution	t _S + 0.5 + N	-	-	

Prerelease product(s)



Table 90. 12-bit ADC characteristics⁽¹⁾⁽²⁾ (continued)

Symbol	Parameter	Conditions	Min	Typ	Max	Unit
I _{DDA_D(ADC)}	Consumption on V _{DDA} and V _{REF-} , differential mode	f _s = 5 MSPS	-	600	-	μA
		f _s = 1 MSPS	-	190	-	
		f _s = 0.1 MSPS	-	50	-	
I _{DDA_SE(ADC)}	Consumption on V _{DDA} and V _{REF-} , single-ended mode	f _s = 5 MSPS	-	500	-	
		f _s = 1 MSPS	-	150	-	
		f _s = 0.1 MSPS	-	50	-	
I _{DD(ADC)}	Consumption on V _{DD}	f _{adc_ker_ck} = 75 MHz	-	265	-	
		f _{adc_ker_ck} = 50 MHz	-	175	-	
		f _{adc_ker_ck} = 25 MHz	-	90	-	
		f _{adc_ker_ck} = 12.5 MHz	-	45	-	
		f _{adc_ker_ck} = 6.25 MHz	-	22	-	
		f _{adc_ker_ck} = 3.125 MHz	-	11	-	

1. Specified by design - Not tested in production.
2. The voltage booster on ADC switches must be used for V_{DDA} < 2.7 V (embedded I/O switches).
3. This frequency is the analog ADC specification, it must respect the value in [Table 18](#).
4. These values are valid on BGA packages.
5. Depending upon the package, V_{REF+} can be internally connected to V_{DDA}, and V_{REF-} to V_{SSA}.
6. The tolerance is two LSBs for 12-, 10-, and 8-bit resolutions, if not otherwise specified.

Table 91. Minimum sampling time versus R_{AIN}⁽¹⁾⁽²⁾

Resolution	R _{AIN} (Ω)	Minimum sampling time (s)	
		Fast channel	Slow channel ⁽³⁾
12 bits	47	TBD	TBD
	68	TBD	TBD
	100	TBD	TBD
	150	TBD	TBD
	220	TBD	TBD
	330	TBD	TBD
	470	TBD	TBD
	680	TBD	TBD

Prerelease product(s)

Table 91. Minimum sampling time versus $R_{AIN}^{(1)(2)}$ (continued)

Resolution	R_{AIN} (Ω)	Minimum sampling time (s)	
		Fast channel	Slow channel ⁽³⁾
10 bits	47	TBD	TBD
	68	TBD	TBD
	100	TBD	TBD
	150	TBD	TBD
	220	TBD	TBD
	330	TBD	TBD
	470	TBD	TBD
	680	TBD	TBD
	1000	TBD	TBD
	1500	TBD	TBD
	2200	TBD	TBD
8 bits	3300	TBD	TBD
	47	TBD	TBD
	68	TBD	TBD
	100	TBD	TBD
	150	TBD	TBD
	220	TBD	TBD
	330	TBD	TBD
	470	TBD	TBD
	680	TBD	TBD
	1000	TBD	TBD
	1500	TBD	TBD
	2200	TBD	TBD
	3300	TBD	TBD
	4700	TBD	TBD
	6800	TBD	TBD
10000	TBD	TBD	
15000	TBD	TBD	

Prerelease product(s)

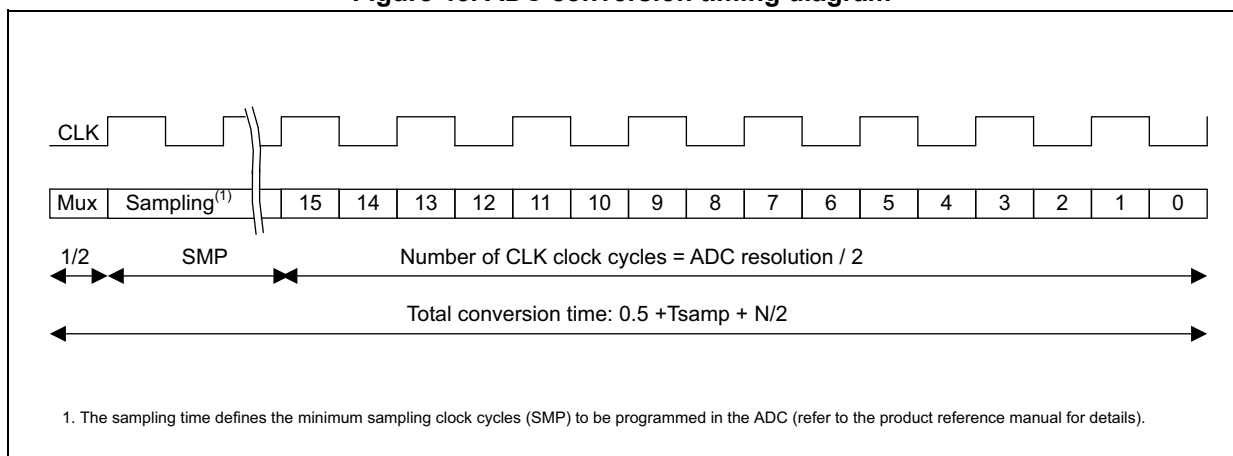

Table 91. Minimum sampling time versus $R_{AIN}^{(1)(2)}$ (continued)

Resolution	R_{AIN} (Ω)	Minimum sampling time (s)	
		Fast channel	Slow channel ⁽³⁾
6 bits	47	TBD	TBD
	68	TBD	TBD
	100	TBD	TBD
	150	TBD	TBD
	220	TBD	TBD
	330	TBD	TBD
	470	TBD	TBD
	680	TBD	TBD
	1000	TBD	TBD
	1500	TBD	TBD
	2200	TBD	TBD
	3300	TBD	TBD
	4700	TBD	TBD
	6800	TBD	TBD
	10000	TBD	TBD
15000	TBD	TBD	

1. Specified by design - Not tested in production.
2. Data valid up to 130°C, with a 22 pF PCB capacitor, and $V_{DDA} = 1.6$ V.
3. Slow channels correspond to all ADC inputs except for the fast channels.

Figure 45. ADC conversion timing diagram



Prerelease product(s)

Table 92. ADC accuracy⁽¹⁾⁽²⁾

Symbol	Parameter	Conditions		Min	Typ	Max	Unit
ET	Total unadjusted error	Fast and slow channels	Single ended	TBD	TBD	TBD	LSB
			Differential	TBD	TBD	TBD	
EO	Offset error	-	Single ended	TBD	TBD	TBD	
		-	Differential	TBD	TBD	TBD	
EG	Gain error	-	Single ended	TBD	TBD	TBD	
		-	Differential	TBD	TBD	TBD	
ED	Differential linearity error	-	Single ended	TBD	TBD	TBD	
		-	Differential	TBD	TBD	TBD	
EL	Integral linearity error	Fast and slow channels	Single ended	TBD	TBD	TBD	
			Differential	TBD	TBD	TBD	
ENOB	Effective number of bits	Single ended		TBD	TBD	TBD	Bits
		Differential		TBD	TBD	TBD	
SINAD	Signal-to-noise and distortion ratio	Single ended		TBD	TBD	TBD	dB
		Differential		TBD	TBD	TBD	
SNR	Signal-to-noise ratio	Single ended		TBD	TBD	TBD	
		Differential		TBD	TBD	TBD	
THD	Total harmonic distortion	Single ended		TBD	TBD	TBD	
		Differential		TBD	TBD	TBD	

1. Evaluated by characterization for BGA packages. The values for LQFP package can differ. Not tested in production.
2. ADC DC accuracy values are measured after internal calibration in continuous mode.

Note: ADC accuracy vs. negative injection current: injecting a negative current on any analog input pins should be avoided as this significantly reduces the accuracy of the conversion being performed on another analog input. It is recommended to add a Schottky diode (pin to ground) to analog pins, which may potentially inject negative currents.

Prerelease product(s)

Figure 46. ADC accuracy characteristics

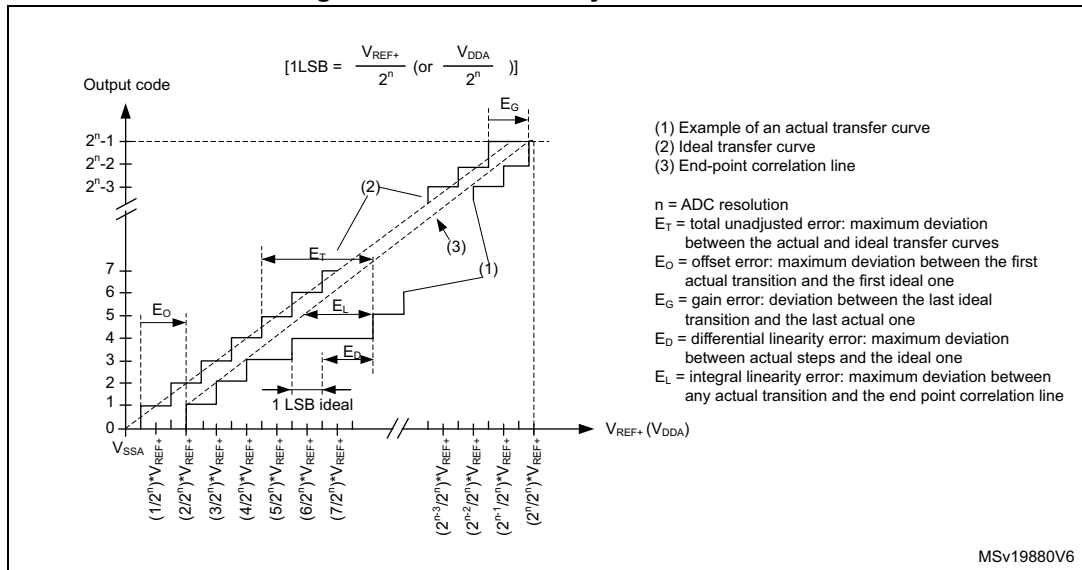

1. Example of an actual transfer curve.
2. Ideal transfer curve.
3. End point correlation line.
4. E_T = Total unadjusted error: maximum deviation between the actual and the ideal transfer curves.
5. E_O = Offset error: deviation between the first actual transition and the first ideal one.
6. E_G = Gain error: deviation between the last ideal transition and the last actual one.
7. E_D = Differential linearity error: maximum deviation between actual steps and the ideal one.
8. E_L = Integral linearity error: maximum deviation between any actual transition and the end point correlation line.

Figure 47. Typical connection diagram when using the ADC with FT/TT pins featuring analog switch function

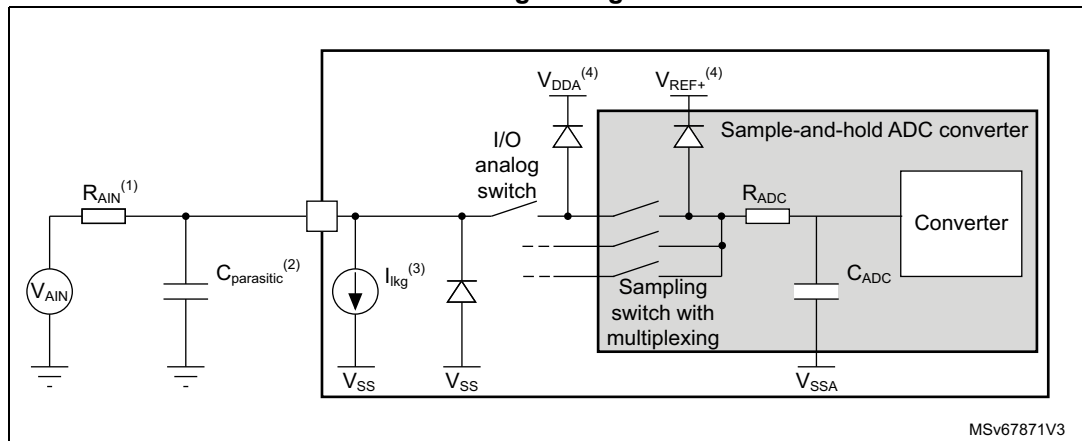

1. Refer to [Table 90](#) for the values of R_{AIN} , and C_{ADC} .
2. $C_{\text{parasitic}}$ represents the capacitance of the PCB (dependent on soldering and PCB layout quality) plus the pad capacitance (refer to [Table 54](#)). A high $C_{\text{parasitic}}$ value downgrades conversion accuracy. To remedy this, f_{ADC} should be reduced.
3. Refer to [Table 54](#) for the value of I_{kg} .
4. Refer to [Figure 17](#).

Prerelease product(s)

General PCB design guidelines

It is recommended to perform power supply decoupling as shown in *Figure 48* or *Figure 49*, depending on whether V_{REF+} is connected to V_{DDA} or not. The 100 nF capacitors must be ceramic (good quality), and placed as close as possible to the chip.

Figure 48. Power supply and reference decoupling (V_{REF+} not connected to V_{DDA})

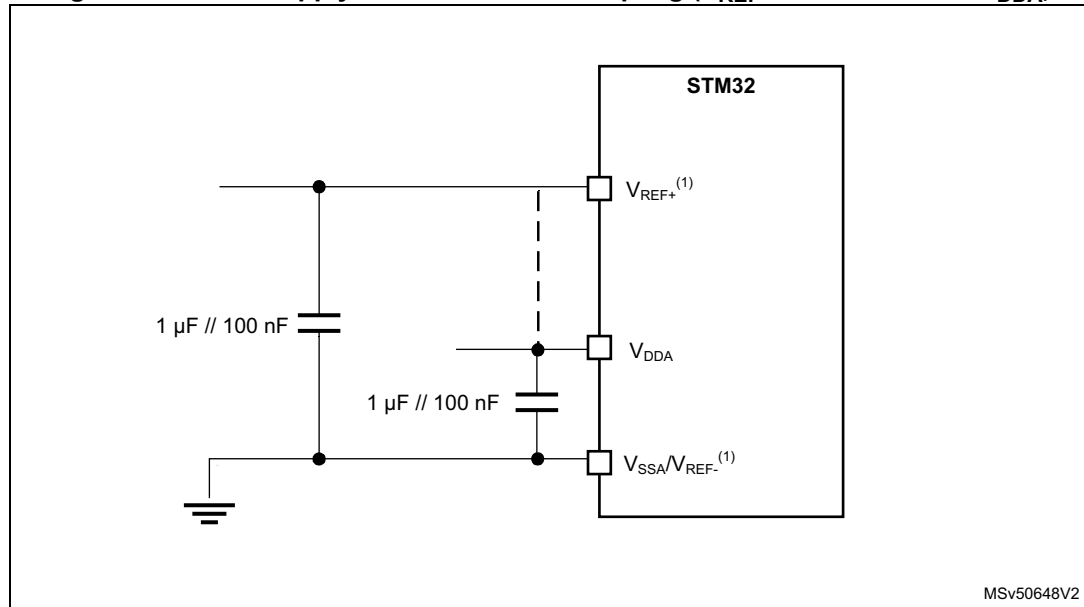

1. V_{REF+} input is not available on all packages (refer to [Table 14](#)), V_{REF-} is available only on LQFP100-EP, LQFP100, and UFBGA144 packages. When V_{REF+} is not available, it is internally connected to V_{SSA} .

Figure 49. Power supply and reference decoupling (V_{REF+} connected to V_{DDA})

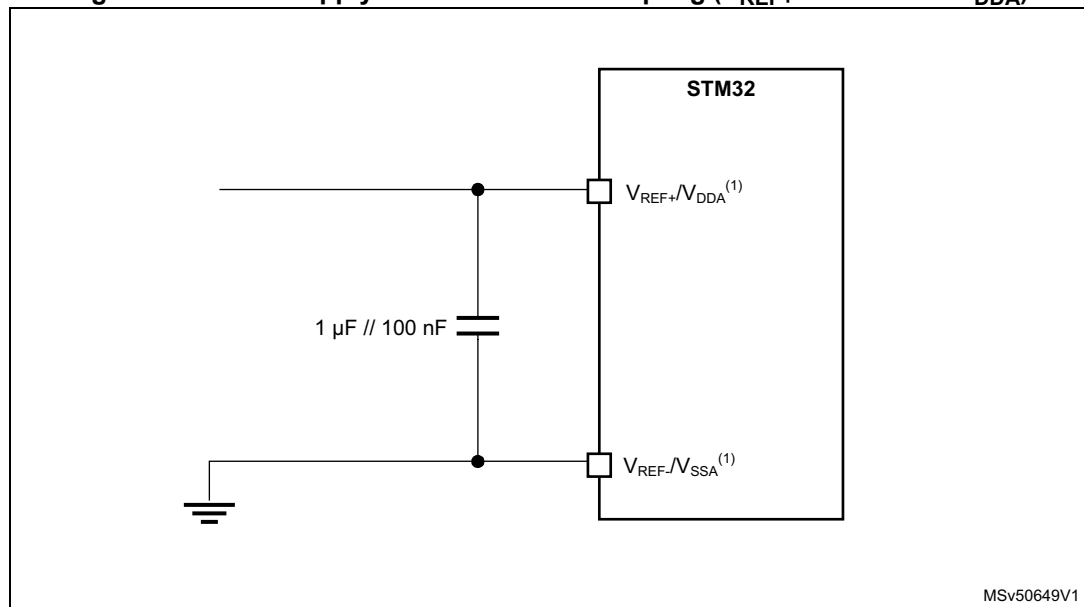

1. V_{REF+} input is not available on all packages (refer to [Table 14](#)), V_{REF-} is available only on LQFP100-EP, LQFP100, UFBGA144 packages. When V_{REF+} is not available, it is internally connected to V_{SSA} . If V_{REF-} is available and connected to V_{DDA} .

Prerelease product(s)

5.3.22 DAC characteristics

Table 93. DAC characteristics⁽¹⁾

Symbol	Parameter	Conditions	Min	Typ	Max	Unit	
V _{DDA}	Analog supply voltage	-	1.8	3.3	3.6	V	
V _{REF+}	Positive reference voltage	-	1.8	-	V _{DDA}		
V _{REF-}	Negative reference voltage	-	-	V _{SSA}	-		
R _L	Resistive load	DAC output buffer ON	Connected to V _{SSA}	5	-	-	kΩ
			Connected to V _{DDA}	25	-	-	
R _O	Output impedance	DAC output buffer OFF		10.3	13	16	
R _{BON}	Output impedance sample and hold mode, output buffer ON	DAC output buffer ON	V _{DD} = 2.7 V	-	-	1.6	kΩ
			V _{DD} = 2.0 V	-	-	2.6	
R _{BOFF}	Output impedance sample and hold mode, output buffer OFF	DAC output buffer OFF	V _{DD} = 2.7 V	-	-	17.8	kΩ
			V _{DD} = 2.0 V	-	-	18.7	
C _L	Capacitive load	DAC output buffer OFF		-	-	50	pF
C _{SH}		Sample and hold mode		-	0.1	1	μF
V _{DAC_OUT}	Voltage on DAC_OUT output	DAC output buffer ON		0.2	-	V _{DDA} -0.2	V
		DAC output buffer OFF		0	-	V _{REF+}	
t _{SETTLING}	Settling time (full scale: for a 12-bit code transition between the lowest and the highest input codes when DAC_OUT reaches the final value of ±0.5LSB, ±1LSB, ±2LSB, ±4LSB, ±8LSB)	Normal mode, DAC output buffer ON, C _L ≤ 50 pF, R _L ≥ 5 kΩ	±0.5 LSB	-	2.05	3	μs
			±1 LSB	-	1.97	2.87	
			±2 LSB	-	1.67	2.84	
			±4 LSB	-	1.66	2.78	
			±8 LSB	-	1.65	2.7	
		Normal mode, DAC output buffer OFF, ±1LSB C _L = 10 pF	-	1.7	2		
t _{WAKEUP} ⁽²⁾	Wake-up time from off state (setting the ENx bit in the DAC control register) until the final value of ±1LSB is reached	Normal mode, DAC output buffer ON, C _L ≤ 50 pF, R _L = 5 kΩ		-	5	7.5	μs
		Normal mode, DAC output buffer OFF, C _L ≤ 10 pF		-	2	5	
PSRR	DC V _{DDA} supply rejection ratio	Normal mode, DAC output buffer ON, C _L ≤ 50 pF, R _L = 5 kΩ		-	-80	-28	dB
t _{SAMP}	Sampling time in Sample and hold mode, C _L = 100 nF (code transition between the lowest and the highest input code when DAC_OUT reaches the ±1LSB final value)	MODE<2:0>_V12 = 100/101 (BUFFER ON)		-	0.7	2.6	ms
		MODE<2:0>_V12 = 110 (BUFFER OFF)		-	11.5	18.7	
		MODE<2:0>_V12=111 ⁽³⁾ (INTERNAL BUFFER OFF)		-	0.3	0.6	μs

Table 93. DAC characteristics⁽¹⁾ (continued)

Symbol	Parameter	Conditions		Min	Typ	Max	Unit
I_{leak}	Output leakage current	-		-	-	(4)	nA
C_{lint}	Internal sample and hold capacitor	-		1.8	2.2	2.6	pF
t_{TRIM}	Middle code offset trim time	Minimum time to verify each code		50	-	-	μs
V_{offset}	Middle code offset for 1 trim code step	$V_{REF+} = 3.6\text{ V}$		-	850	-	μV
		$V_{REF+} = 1.8\text{ V}$		-	425	-	
$I_{DDA(DAC)}$	DAC quiescent consumption from V_{DDA}	DAC output buffer ON	No load, middle code (0x800)	-	360	-	μA
			No load, worst code (0xF1C)	-	490	-	
		DAC output buffer OFF	No load, middle/worst code (0x800)	-	20	-	
		Sample and hold mode, $C_{SH} = 100\text{ nF}$		-	$360 \cdot T_{ON} / (T_{ON} + T_{OFF})^{(5)}$	-	
$I_{DDV(DAC)}$	DAC consumption from V_{REF+}	DAC output buffer ON	No load, middle code (0x800)	-	170	-	μA
			No load, worst code (0xF1C)	-	170	-	
		DAC output buffer OFF	No load, middle/worst code (0x800)	-	160	-	
		Sample and hold mode, buffer ON, $C_{SH} = 100\text{ nF}$ (worst code)		-	$170 \cdot T_{ON} / (T_{ON} + T_{OFF})^{(5)}$	-	
		Sample and hold mode, buffer OFF, $C_{SH} = 100\text{ nF}$ (worst code)		-	$160 \cdot T_{ON} / (T_{ON} + T_{OFF})^{(5)}$	-	

1. Specified by design - Not tested in production, unless otherwise specified.
2. In buffered mode, the output can overshoot above the final value for low input code (starting from the minimum value).
3. DACx_OUT pin is not connected externally (internal connection only).
4. Refer to [Table 54](#).
5. T_{ON} is the refresh phase duration, T_{OFF} is the hold phase duration. Refer to the reference manual for more details.

Prerelease product(s)

Table 94. DAC accuracy⁽¹⁾

Symbol	Parameter	Conditions	Min	Typ	Max	Unit	
DNL	Differential non linearity ⁽²⁾	DAC output buffer ON	-2	-	2	LSB	
		DAC output buffer OFF	-2	-	2		
-	Monotonicity	10 bits	-	-	-	-	
INL	Integral non linearity ⁽³⁾	DAC output buffer ON, $C_L \leq 50 \text{ pF}$, $R_L \geq 5 \text{ k}\Omega$	-4	-	4		
		DAC output buffer OFF, $C_L \leq 50 \text{ pF}$, no R_L	-4	-	4		
Offset	Offset error at code 0x800 ⁽³⁾	DAC output buffer ON, $C_L \leq 50 \text{ pF}$, $R_L \geq 5 \text{ k}\Omega$	$V_{REF+} = 3.6 \text{ V}$	-	-	± 12	LSB
			$V_{REF+} = 1.8 \text{ V}$	-	-	± 25	
		DAC output buffer OFF, $C_L \leq 50 \text{ pF}$, no R_L		-	-	± 8	
Offset1	Offset error at code 0x001 ⁽⁴⁾	DAC output buffer OFF, $C_L \leq 50 \text{ pF}$, no R_L	-	-	± 5		
OffsetCal	Offset error at code 0x800 after factory calibration	DAC output buffer ON, $C_L \leq 50 \text{ pF}$, $R_L \geq 5 \text{ k}\Omega$	$V_{REF+} = 3.6 \text{ V}$	-	-	± 5	
			$V_{REF+} = 1.8 \text{ V}$	-	-	± 7	
Gain	Gain error ⁽⁵⁾	DAC output buffer ON, $C_L \leq 50 \text{ pF}$, $R_L \geq 5 \text{ k}\Omega$	-	-	± 1	%	
		DAC output buffer OFF, $C_L \leq 50 \text{ pF}$, no R_L	-	-	± 1		
TUE	Total unadjusted error	DAC output buffer ON, $C_L \leq 50 \text{ pF}$, $R_L \geq 5 \text{ k}\Omega$	-	-	± 30	LSB	
		DAC output buffer OFF, $C_L \leq 50 \text{ pF}$, no R_L			± 12		
TUECal	Total unadjusted error after calibration	DAC output buffer ON, $C_L \leq 50 \text{ pF}$, $R_L \geq 5 \text{ k}\Omega$	-	-	± 23		
SNR	Signal-to-noise ratio ⁽⁶⁾	DAC output buffer ON, $C_L \leq 50 \text{ pF}$, $R_L \geq 5 \text{ k}\Omega$, 1 kHz, BW = 500 kHz	-	67.8	-		
		DAC output buffer OFF, $C_L \leq 50 \text{ pF}$, no R_L , 1 kHz, BW = 500 kHz	-	67.8	-		
THD	Total harmonic distortion ⁽⁶⁾	DAC output buffer ON, $C_L \leq 50 \text{ pF}$, $R_L \geq 5 \text{ k}\Omega$, 1 kHz	-	-78.6	-	dB	
		DAC output buffer OFF, $C_L \leq 50 \text{ pF}$, no R_L , 1 kHz	-	-78.6	-		
SINAD	Signal-to-noise and distortion ratio ⁽⁶⁾	DAC output buffer ON, $C_L \leq 50 \text{ pF}$, $R_L \geq 5 \text{ k}\Omega$, 1 kHz	-	67.5	-		
		DAC output buffer OFF, $C_L \leq 50 \text{ pF}$, no R_L , 1 kHz	-	67.5	-		

Table 94. DAC accuracy⁽¹⁾ (continued)

Symbol	Parameter	Conditions	Min	Typ	Max	Unit
ENOB	Effective number of bits	DAC output buffer ON, $C_L \leq 50$ pF, $R_L \geq 5$ k Ω , 1 kHz	-	10.9	-	bits
		DAC output buffer OFF, $C_L \leq 50$ pF, no R_L , 1 kHz	-	10.9	-	

1. Evaluated by characterization - Not tested in production.
2. Difference between two consecutive codes minus 1 LSB.
3. Difference between the value measured at Code i and the value measured at Code i on a line drawn between Code 0 and last Code 4095.
4. Difference between the value measured at Code (0x001) and the ideal value.
5. Difference between the ideal slope of the transfer function and the measured slope computed from code 0x000 and 0xFFFF when the buffer is OFF, and from code giving 0.2 V and ($V_{REF+} - 0.2$ V) when the buffer is ON.
6. Signal is -0.5 dBFS with $F_{sampling} = 1$ MHz.

Figure 50. 12-bit buffered/non-buffered DAC

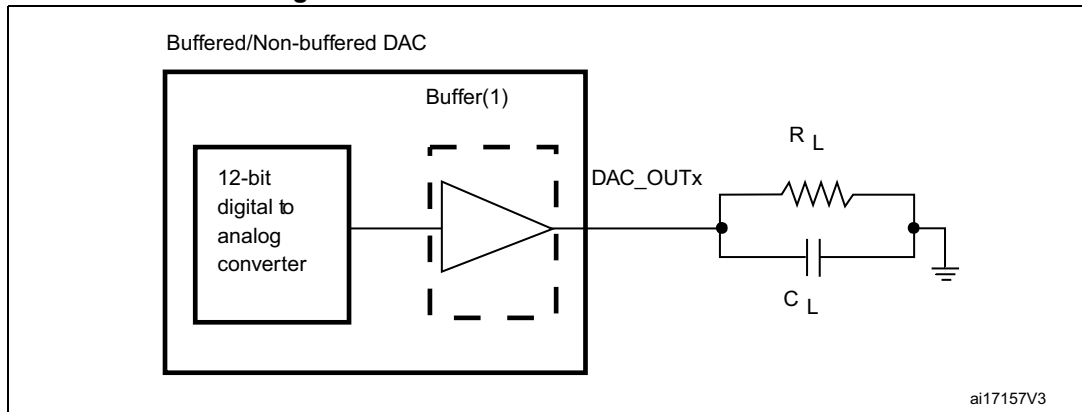

1. The DAC integrates an output buffer that can be used to reduce the output impedance and to drive external loads directly, without the use of an external operational amplifier. The buffer can be bypassed by configuring the BOFFx bit in the DAC_CR register.

5.3.23 Analog temperature sensor characteristics

Table 95. Analog temperature sensor characteristics

Symbol	Parameter	Min	Typ	Max	Unit
$T_L^{(1)}$	V_{SENSE} linearity with temperature (from V_{SENSOR} voltage)	-	-	3	$^{\circ}C$
	V_{SENSE} linearity with temperature (from ADC counter)	-	-	3	
Avg_Slope ⁽²⁾	Average slope (from V_{SENSOR} voltage)	-	2	-	mV/ $^{\circ}C$
	Average slope (from ADC counter)	-	2	-	
$V_{30}^{(3)}$	Voltage at $30^{\circ}C \pm 5^{\circ}C$	-	0.62	-	V
t_{start_run}	Startup time in Run mode (buffer startup)	-	-	25.2	μs
$t_{S_temp}^{(1)}$	ADC sampling time when reading the temperature	9	-	-	
$I_{sens}^{(1)}$	Sensor consumption	-	0.18	0.31	μA
$I_{sensbuf}^{(1)}$	Sensor buffer consumption	-	3.8	6.5	

Prerelease product(s)

1. Specified by design - Not tested in production.
2. Evaluated by characterization - Not tested in production.
3. Measured at $V_{DDA} = 3.3\text{ V} \pm 10\text{ mV}$. The V_{30} ADC conversion result is stored in the TS_CAL1 bytes.

Table 96. Temperature sensor calibration values

Symbol	Parameter	Memory address
TS_CAL1	Temperature sensor raw data acquired value at 30°C, $V_{DDA} = 3.3\text{ V}$	0x08FF F814 - 0x08FF F815
TS_CAL2	Temperature sensor raw data acquired value at 130°C, $V_{DDA} = 3.3\text{ V}$	0x08FF F818 - 0x08FF F819

5.3.24 Digital temperature sensor characteristics

Table 97. Digital temperature sensor characteristics⁽¹⁾

Symbol	Parameter	Conditions	Min	Typ	Max	Unit
$f_{DTS}^{(2)}$	Output clock frequency	-	500	750	1150	kHz
$T_{LC}^{(2)}$	Temperature linearity coefficient	VOS2	1660	2100	2750	Hz/°C
$T_{TOTAL_ERROR}^{(2)}$	Temperature offset measurement, all VOS	$T_J = -40\text{ to }30\text{ °C}$	-13	-	4	°C
		$T_J = 30\text{ °C to }T_{Jmax}$	-7	-	2	
T_{VDD_CORE}	Additional error due to supply variation	VOS2	0	-	0	°C
		VOS0, VOS1, VOS3	-1	-	1	
t_{TRIM}	Calibration time	-	-	-	2	ms
t_{WAKE_UP}	Wake-up time from off state until DTS ready bit is set	-	-	67	116	µs
I_{DDCORE_DTS}	DTS consumption on V_{DD_CORE}	-	8.5	30	70	µA

1. Specified by design - Not tested in production, unless otherwise specified.
2. Evaluated by characterization - Not tested in production.

5.3.25 V_{CORE} monitoring characteristics

Table 98. V_{CORE} monitoring characteristics⁽¹⁾

Symbol	Parameter	Min	Typ	Max	Unit
T_{S_VCORE}	ADC sampling time when reading the V_{CORE} voltage	1	-	-	µs

1. Specified by design - Not tested in production.

Prerelease product(s)

5.3.26 Temperature and V_{BAT} monitoring

Table 99. V_{BAT} monitoring characteristics

Symbol	Parameter	Min	Typ	Max	Unit
R	Resistor bridge for V _{BAT}	-	4 x 26	-	kΩ
Q ⁽¹⁾	Ratio on V _{BAT} measurement	-	4	-	-
Er ⁽²⁾	Error on Q	-10	-	+10	%
t _{S_vbat} ⁽²⁾	ADC sampling time when reading V _{BAT} input	9	-	-	μs
V _{BAThigh}	High supply monitoring	3.50	3.575	3.63	V
V _{BATlow}	Low supply monitoring	-	1.36	-	
I _{VBATbuf}	Sensor buffer consumption	-	3.8	6.5	μA

- 1.2 V ≤ V_{BAT} ≤ 3.63 V.
- Specified by design - Not tested in production.

Table 100. V_{BAT} charging characteristics

Symbol	Parameter	Conditions	Min	Typ	Max	Unit
R _{BC}	Battery charging resistor	VBRS in PWR_CR3 = 0	-	5	-	kΩ
		VBRS in PWR_CR3 = 1	-	1.5	-	

Table 101. Temperature monitoring characteristics

Symbol	Parameter	Min	Typ	Max	Unit
TEMP _{high}	High temperature monitoring	-	126	-	°C
TEMP _{low}	Low temperature monitoring	-	-37	-	

5.3.27 Voltage booster for analog switch

Table 102. Voltage booster for analog switch characteristics⁽¹⁾

Symbol	Parameter	Conditions	Min	Typ	Max	Unit
V _{DD}	Supply voltage	-	1.71	2.6	3.6	V
t _{SU(BOOST)}	Booster startup time	-	-	-	50	μs
I _{DD(BOOST)}	Booster consumption	1.71 V ≤ V _{DD} ≤ 2.7 V	-	-	125	μA
		2.7 V < V _{DD} < 3.6 V	-	-	250	

- Evaluated by characterization - Not tested in production.

Prerelease product(s)

5.3.28 VREFBUF characteristics

Table 103. VREFBUF characteristics⁽¹⁾

Symbol	Parameter	Conditions		Min	Typ	Max	Unit
V _{DDA}	Analog supply voltage	Normal mode at V _{DDA} = 3.3 V	VRS = 000	2.8	3.3	3.6	V
			VRS = 001	2.4	-	3.6	
			VRS = 010	2.1	-	3.6	
		Degraded mode ⁽²⁾	VRS = 000	1.62	-	2.80	
			VRS = 001	1.62	-	2.40	
			VRS = 010	1.62	-	2.10	
V _{REFBUF_OUT}	Voltage reference buffer output	Normal mode at 30°C, I _{LOAD} = 100 µA	VRS = 000	2.4980 ⁽³⁾	2.5000	2.5035 ⁽³⁾	V
			VRS = 001	2.0460	2.0490	2.0520	
			VRS = 010	1.8010	1.8040	1.8060	
		Degraded mode ⁽²⁾	VRS = 000	V _{DDA} - 150 mV	-	2.5035	
			VRS = 001		-	2.0520	
			VRS = 010		-	1.8060	
TRIM	Trim step resolution	-	-	-	±0.05	±0.1	%
C _L	Load capacitor	-	-	0.5	1	1.50	µF
esr	Equivalent serial resistor of C _L	-	-	-	-	2	Ω
I _{load}	Static load current	-	-	-	-	4	mA
I _{line_reg}	Line regulation	2.8 V ≤ V _{DDA} ≤ 3.6 V	I _{load} = 500 µA	-	200	-	ppm/V
			I _{load} = 4 mA	-	100	-	
I _{load_reg}	Load regulation	500 µA ≤ I _{load} ≤ 4 mA	Normal mode	-	50	-	ppm/mA
T _{coeff}	Temperature coefficient	-40°C < T _J < +140°C	-	-	-	100	ppm/°C
PSRR	Power supply rejection	DC	-	-	60	-	dB
		100 kHz	-	-	40	-	
t _{START}	Start-up time	C _L = 0.5 µF	-	-	300	-	µs
		C _L = 1 µF	-	-	500	-	
		C _L = 1.5 µF	-	-	650	-	
I _{INRUSH}	Control of maximum DC current drive on V _{REFBUF_OUT} during startup ⁽⁴⁾	-	-	-	8	-	mA

Prerelease product(s)

Table 103. VREFBUF characteristics⁽¹⁾ (continued)

Symbol	Parameter	Conditions		Min	Typ	Max	Unit
I _{DDA(VREFBUF)}	Consumption from V _{DDA}	I _{LOAD} = 0 μA	-	-	15	25	μA
		I _{LOAD} = 500 μA	-	-	16	30	
		I _{LOAD} = 4 mA	-	-	32	50	

1. Specified by design - Not tested in production, unless otherwise specified.
2. In degraded mode, the voltage reference buffer cannot accurately maintain the output voltage (V_{DDA}-drop voltage).
3. Evaluated by characterization - Not tested in production.
4. To properly control V_{REFBUF} I_{INRUSH} current during the startup phase and the change of scaling, V_{DDA} voltage must be in the range of 2.1 V - 3.6 V, 2.4 V -3.6 V, and 2.8 V - 3.6 V, respectively, for VRS = 010, 001, and 000.

5.3.29 Comparator characteristics

Table 104. COMP characteristics⁽¹⁾

Symbol	Parameter	Conditions	Min	Typ	Max	Unit
V _{DDA}	Analog supply voltage	-	1.62	3.3	3.6	V
V _{IN}	Comparator input voltage range	-	0	-	V _{DDA}	
V _{BG} ⁽²⁾	Scaler input voltage	-	-			
V _{SC}	Scaler offset voltage	-	-	±5	±10	mV
I _{DDA(SCALER)}	Scaler static consumption from V _{DDA}	BRG_EN=0 (bridge disable)	-	0.2	0.3	μA
		BRG_EN=1 (bridge enable)	-	0.8	1	
t _{START_SCALER}	Scaler startup time	-	-	140	250	μs
t _{START}	Comparator startup time to reach propagation delay specification	High-speed mode	-	2	5	μs
		Medium mode	-	5	20	
		Ultra-low-power mode	-	15	80	
t _D ⁽³⁾	Propagation delay for 200 mV step with 100 mV overdrive	High-speed mode	-	50	80	ns
		Medium mode	-	0.5	0.9	
		Ultra-low-power mode	-	2.5	7	
	Propagation delay for step > 200 mV with 100 mV overdrive only on positive inputs	High-speed mode	-	50	120	ns
		Medium mode	-	0.5	1.2	
		Ultra-low-power mode	-	2.5	7	
V _{offset}	Comparator offset error	Full common mode range	-	±5	±20	mV
V _{hys}	Comparator hysteresis	No hysteresis	-	0	-	mV
		Low hysteresis	4	10	22	
		Medium hysteresis	8	20	37	
		High hysteresis	16	30	52	

Prerelease product(s)

Table 104. COMP characteristics⁽¹⁾ (continued)

Symbol	Parameter	Conditions		Min	Typ	Max	Unit
I _{DDA} (COMP)	Comparator consumption from V _{DDA}	Ultra-low-power mode	Static	-	400	600	nA
			With 50 kHz ±100 mV overdrive square signal	-	800	-	
		Medium mode	Static	-	5	7	µA
			With 50 kHz ±100 mV overdrive square signal	-	6	-	
		High-speed mode	Static	-	70	100	
			With 50 kHz ±100 mV overdrive square signal	-	75	-	

1. Specified by design - Not tested in production, unless otherwise specified.
2. Refer to [Section 5.3.5: Embedded reference voltage](#).
3. Evaluated by characterization - Not tested in production.

5.3.30 Timer characteristics

The parameters given in [Table 105](#) are guaranteed by design.

Refer to [Section 5.3.14](#) for details on the input/output alternate function characteristics (output compare, input capture, external clock, PWM output).

Table 105. TIMx characteristics⁽¹⁾⁽²⁾

Symbol	Parameter	Conditions ⁽³⁾	Min	Max	Unit
t _{res} (TIM)	Timer resolution time	AHB/APBx prescaler = 1, 2, or 4, f _{TIMxCLK} = 250 MHz	1	-	t _{TIMxCLK}
		AHB/APBx prescaler > 4, f _{TIMxCLK} = 125 MHz	1	-	t _{TIMxCLK}
f _{EXT}	Timer external clock frequency on CH1 to CH4	f _{TIMxCLK} = 250 MHz	0	f _{TIMxCLK} / 2	MHz
Res _{TIM}	Timer resolution		-	16 / 32	bit
t _{MAX_COUNT}	Maximum possible count with 32-bit counter	-	-	65536 × 65536	t _{TIMxCLK}

1. TIMx is used as a general term to refer to the TIM1 to TIM17 timers.
2. Specified by design - Not tested in production.
3. The maximum timer frequency on APB1 or APB2 is up to 250 MHz, by setting the TIMPRE bit in the RCC_CFGR register, if APBx prescaler is 1 or 2 or 4, then TIMxCLK = rcc_hclk1, otherwise TIMxCLK = 4 × F_{rcc_pclkx1} or TIMxCLK = 4 × F_{rcc_pclkx2}.

Prerelease product(s)

5.3.31 Low-power timer characteristics

Table 106. LPTIMx characteristics⁽¹⁾⁽²⁾

Symbol	Parameter	Min	Max	Unit
$t_{res(TIM)}$	Timer resolution time	1	-	$t_{lptim_ker_ck}$
$f_{lptim_ker_ck}$	Timer kernel clock	0	250	MHz
f_{EXT}	Timer external clock frequency on Input1 and Input2	0	$f_{lptim_ker_ck} / 3$	
Res _{TIM}	Timer resolution	-	16	bit
t_{MAX_COUNT}	Maximum possible count	-	65535	$t_{lptim_ker_ck}$

1. LPTIMx is used as a general term for LPTIM1 to LPTIM6 timers.
2. Specified by design - Not tested in production.

5.3.32 Communication interfaces

I²C interface characteristics

The I²C interface meets the timings requirements of the I²C-bus specification and user manual revision 03 for:

- Standard-mode (Sm): with a bit rate up to 100 kbit/s
- Fast-mode (Fm): with a bit rate up to 400 kbit/s
- Fast-mode Plus (Fm+): with a bit rate up to 1 Mbit/s.

The I²C timings requirements are specified by design, not tested in production, when the I²C peripheral is properly configured (refer to the product reference manual)

The SDA and SCL I/O requirements are met with the following restrictions:

- The SDA and SCL I/O pins are not “true” open-drain. When configured as open-drain, the PMOS connected between the I/O pin and V_{DD} is disabled, but still present. Only FT_f I/O pins support Fm+ low level output current maximum requirement. Refer to [Section 5.3.14](#) for the I2C I/Os characteristics

All I²C SDA and SCL I/Os embed an analog filter, refer to [Table 107](#) for its characteristics.

Table 107. I²C analog filter characteristics⁽¹⁾⁽²⁾

Symbol	Parameter	Min	Max	Unit
t_{AF}	Maximum pulse width of spikes suppressed by analog filter	50 ⁽³⁾	160 ⁽⁴⁾	ns

1. Evaluated by characterization - Not tested in production.
2. Measurement points are done at 50% V_{DD}.
3. Spikes with widths below $t_{AF(min)}$ are filtered.
4. Spikes with widths above $t_{AF(max)}$ are not filtered.

USART interface characteristics

Unless otherwise specified, the parameters given in [Table 108](#) are derived from tests performed under the ambient temperature, f_{PCLKx} frequency, and V_{DD} supply voltage conditions summarized in [Table 17](#), with the following configuration:

- Output speed is set to OSPEEDRy[1:0] = 10
- Capacitive load $C_L = 30$ pF
- Measurement points are done at CMOS levels: $0.5 V_{DD}$
- I/O compensation cell activated
- VOS level set to VOS0
- HSLV activated when $V_{DD} \leq 2.7$ V

Refer to [Section 5.3.14](#) for more details on the input/output alternate function characteristics (NSS, CK, TX, RX for USART).

Table 108. USART characteristics⁽¹⁾

Symbol	Parameter	Conditions	Min	Typ	Max	Unit
f_{CK}	USART clock frequency	Master receiver $1.71\text{ V} < V_{DD} < 3.6\text{ V}$	-	-	31	MHz
		Master transmitter $1.71\text{ V} < V_{DD} < 3.6\text{ V}$			$31/6^{(2)}$	
		Master transmitter $2.7\text{ V} < V_{DD} < 3.6\text{ V}$			$31/6^{(2)}$	
		Slave receiver $1.71\text{ V} < V_{DD} < 3.6\text{ V}$			83	
		Slave transmitter $1.71\text{ V} < V_{DD} < 3.6\text{ V}$			$32/6^{(2)}$	
		Slave transmitter $2.7\text{ V} < V_{DD} < 3.6\text{ V}$			$35/6^{(2)}$	
$t_{su(NSS)}$	NSS setup time	Slave mode	$t_{ker}^{(3)} + 3.5$	-	-	ns
$t_{h(NSS)}$	NSS hold time	Slave mode	2.5	-	-	
$t_w(SCKH)$ $t_w(SCKL)$	CK high and low time	Master mode	$1/f_{ck}/2 - 1$	$1/f_{ck}/2$	$1/f_{ck}/2 + 1$	
		Master mode	13	-	-	
$t_{su(RX)}$	Data input setup time	Slave mode	3.5	-	-	
		Slave mode	0.5	-	-	
$t_{h(RX)}$	Data input hold time	Slave mode	1.5	-	-	
		Slave mode	-	11.5	$15.5/71^{(2)}$	
$t_{v(TX)}$	Data output valid time	Slave mode, $1.71\text{ V} < V_{DD} < 3.6\text{ V}$	-	11.5	$14/35^{(2)}$	
		Slave mode, $2.7\text{ V} < V_{DD} < 3.6\text{ V}$	-		$3/52^{(2)}$	
		Slave mode, $1.71\text{ V} < V_{DD} < 3.6\text{ V}$	-	2.5	$3/22^{(2)}$	
		Slave mode, $2.7\text{ V} < V_{DD} < 3.6\text{ V}$	-		$3/22^{(2)}$	

Prerelease product(s)

Table 108. USART characteristics⁽¹⁾ (continued)

Symbol	Parameter	Conditions	Min	Typ	Max	Unit
$t_{h(TX)}$	Data output hold time	Slave mode	7.5	-	-	ns
		Master mode	0	-	-	

1. Evaluated by characterization - Not tested in production.
2. For PB14 with OSPEEDRy[1:0] = 01.
3. T_{ker} is the usart_ker_ck_pres clock period.

Figure 51. USART timing diagram in Master mode

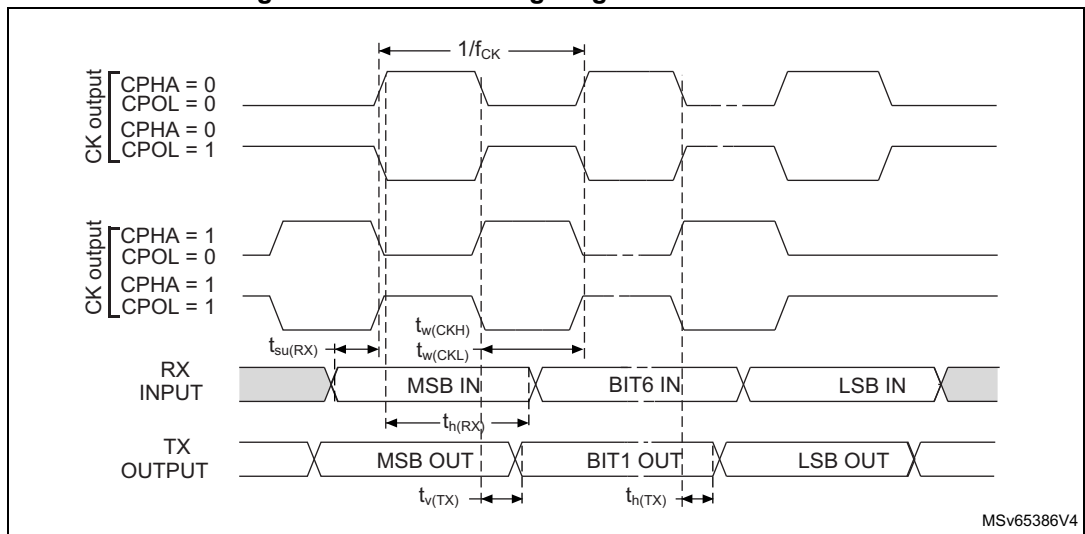

1. Measurement points are done at $0.5V_{DD}$ and with external $C_L = 30$ pF.

Figure 52. USART timing diagram in Slave mode

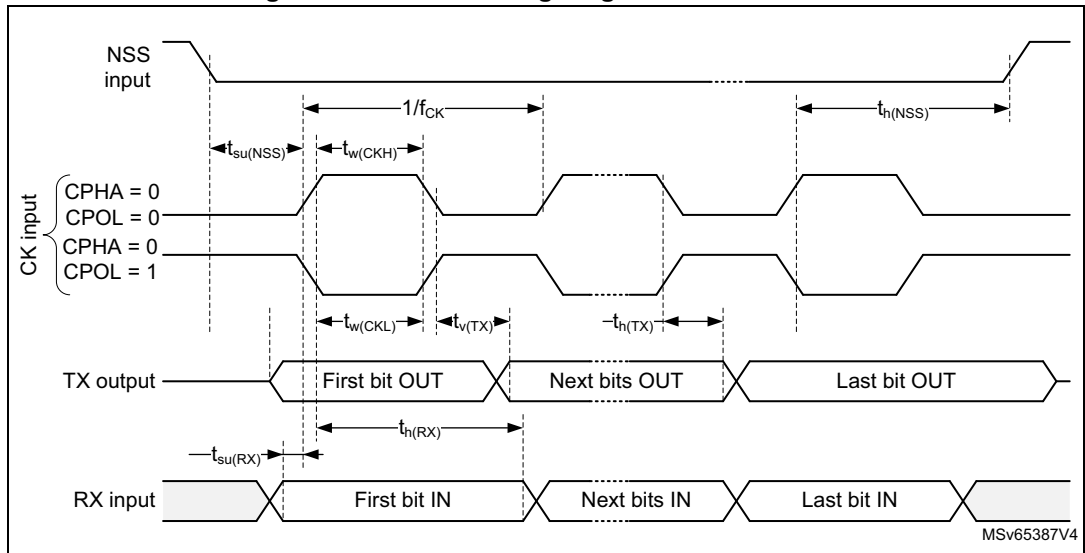

Prerelease product(s)

I3C interface characteristics

The I3C interface meets the timings requirements of the MIPI® I3C specification v1.1.

The I3C peripheral supports:

- I3C SDR-only as controller
- I3C SDR-only as target
- I3C SCL bus clock frequency up to 12.5 MHz

The parameters given in [Table 109](#) are obtained with the following configuration:

- Output speed is set to OSPEEDRy[1:0] = 10
- I/O compensation cell activated
- HSLV activated when $V_{DD} \leq 2.7$ V
- VOS level set to VOS0

The timings are in line with MIPI specification, except for the ones given in [Table 109](#) and [Table 110](#). For t_{SU_OD} this can be mitigated by increasing the corresponding SCL low duration in the I3C_TIMINGR0 register. For t_{SCO} this can be mitigated by enabling and adjusting the clock stall time both on the address ACK phase and on the data read Tbit phase in the I3C_TIMINGR2 register. This can also be mitigated by increasing the SCL low duration in the I3C_TIMINGR0 register. For further details, refer to AN5879.

Table 109. I3C open-drain measured timings

Symbol	Parameter	Conditions	Min	Unit
t_{SU_OD}	SDA data setup time during open drain mode	Controller $1.71\text{ V} < V_{DD} < 3.6\text{ V}$	18 ⁽¹⁾	ns
		Controller $1.08\text{ V} < V_{DDIO2} < 1.32\text{ V}$	24 ⁽¹⁾	

1. SDA data setup time in open-drain mode must be at least 3 ns, as required by the MIPI specification.

Table 110. I3C push-pull measured timings

Symbol	Parameter	Conditions	Max	Unit
t_{SCO}	Clock in to data out for target	Target $1.71\text{ V} < V_{DD} < 3.6\text{ V}$	9	ns
		Target $1.2\text{ V} < V_{DDIO2} < 1.32\text{ V}$	14 ⁽¹⁾	ns
		Target $1.08\text{ V} < V_{DDIO2} < 1.2\text{ V}$	16.5	

1. The t_{SCO} clock-in to Data-out time must not exceed 12 ns in the MIPI specification.

SPI interface characteristics

Unless otherwise specified, the parameters given in [Table 111](#) are derived from tests performed under the ambient temperature, f_{PCLKx} frequency, and V_{DD} supply voltage conditions summarized in [Table 17](#), with the following configuration:

- Output speed is set to OSPEEDRy[1:0] = 11
- Capacitive load $C_L = 30$ pF

- Measurement points are done at CMOS levels: 0.5 V_{DD}
- I/O compensation cell activated
- HSLV activated when V_{DD} ≤ 2.7 V
- VOS level set to VOS0

Refer to [Section 5.3.14](#) for more details on the input/output alternate function characteristics (NSS, SCK, MOSI, MISO for SPI).

Table 111. SPI characteristics⁽¹⁾

Symbol	Parameter	Conditions	Min	Typ	Max	Unit
f _{SCK} 1/t _{SCK}	SPI clock frequency	Master receiver mode 2.7 V < V _{DD} < 3.6 V	-	-	125/3 ⁽²⁾ /100 ⁽³⁾	MHz
		Master receiver mode 1.71 V < V _{DD} < 2.7 V	-	-	110/3 ⁽²⁾ /88 ⁽³⁾	
		Master receiver mode 1.08 V < V _{DDIO2} < 1.32 V	-	-	44	
		Master transmitter mode 2.7 V < V _{DD} < 3.6 V			125/3 ⁽²⁾ /100 ⁽³⁾	
		Master transmitter mode 1.71 V < V _{DD} < 2.7 V	-	-	120/3 ⁽²⁾ /96 ⁽³⁾	
		Master transmitter mode 1.08 V < V _{DDIO2} < 1.32 V			44	
		Slave receiver mode 1.08 V < V _{DD} < 3.6 V	-	-	125	
		Slave transmitter mode 1.08 V < V _{DD} < 3.6 V	-	-	43/6 ⁽⁴⁾	
		Slave transmitter mode 1.71 V < V _{DD} < 2.7 V	-	-	41/6 ⁽⁴⁾	
		Slave transmitter mode 1.08 V < V _{DDIO2} < 1.32 V	-	-	23	
t _{su(NSS)}	NSS setup time	Slave mode	3.5	-	-	ns
t _{h(NSS)}	NSS hold time	Slave mode	4.5	-	-	
t _{w(SCKH)} t _{w(SCKL)}	SCK high and low time	Master mode	(t _{SCK} /2) - 1	t _{SCK} /2	(t _{SCK} /2) + 1	ns
t _{su(MI)}	Data input setup time	Master mode	3.5	-	-	ns
t _{su(SI)}		Slave mode	2	-	-	
t _{h(MI)}	Data input hold time	Master mode	1	-	-	ns
t _{h(SI)}		Slave mode	1.5	-	-	
t _{a(SO)}	Data output access time	Slave mode	6.5	-	15	ns
t _{dis(SO)}	Data output disable time	Slave mode	7.5	-	18	

Prerelease product(s)

Table 111. SPI characteristics⁽¹⁾ (continued)

Symbol	Parameter	Conditions	Min	Typ	Max	Unit
$t_{v(SO)}$	Data output valid time	Slave mode $2.7\text{ V} < V_{DD} < 3.6\text{ V}$	-	8.5/25 ⁽⁴⁾	11.5/33 ⁽⁴⁾	ns
		Slave mode $1.71\text{ V} < V_{DD} < 2.7\text{ V}$	-	10/59 ⁽⁴⁾	12/76 ⁽⁴⁾	
		Slave mode $1.08\text{ V} < V_{DDIO2} < 1.32\text{ V}$	-	18	21.5	
$t_{v(MO)}$		Master mode	-	1.5	2	
$t_{h(SO)}$	Data output hold time	Slave mode $1.71\text{ V} < V_{DD} < 3.6\text{ V}$	6.5/20.5 ⁽⁴⁾	-	-	ns
$t_{h(MO)}$		Master mode	0	-	-	

1. Evaluated by characterization - Not tested in production.
2. When using PB13.
3. Maximum speed for LQFP100.
4. When using PB14.

Figure 53. SPI timing diagram - Master mode

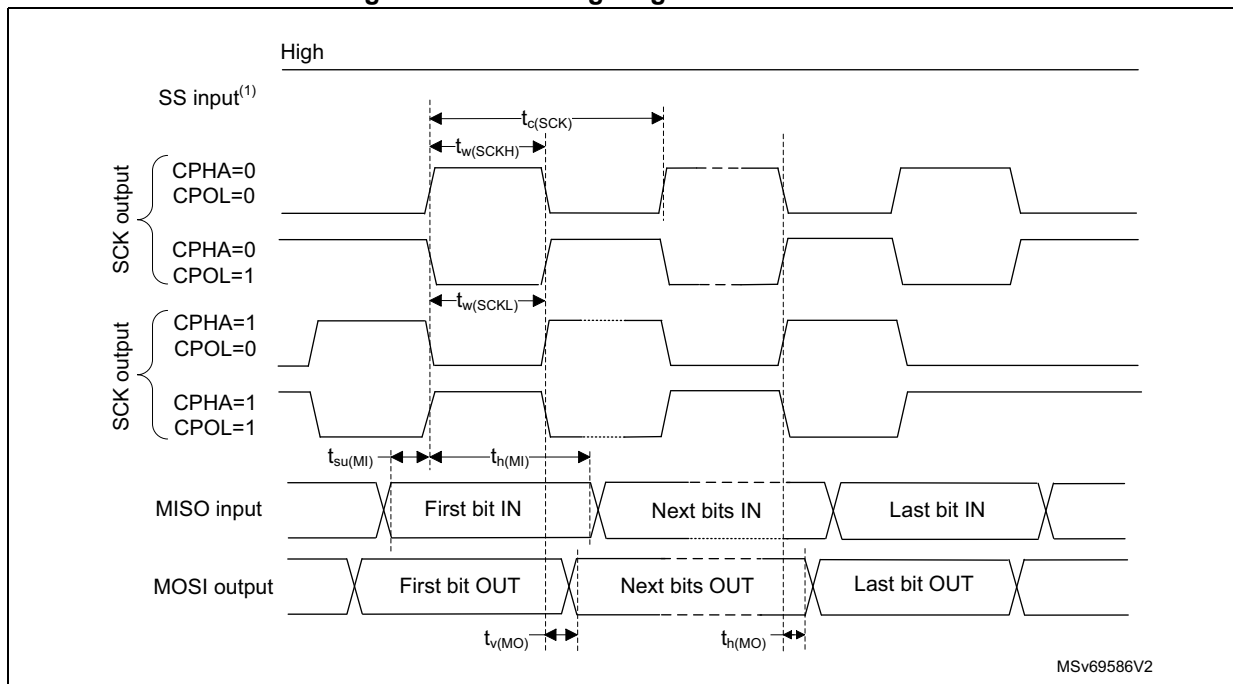

1. The SS input can be configured to active low or active high.

Prerelease product(s)

Figure 54. SPI timing diagram - Slave mode and CPHA = 0

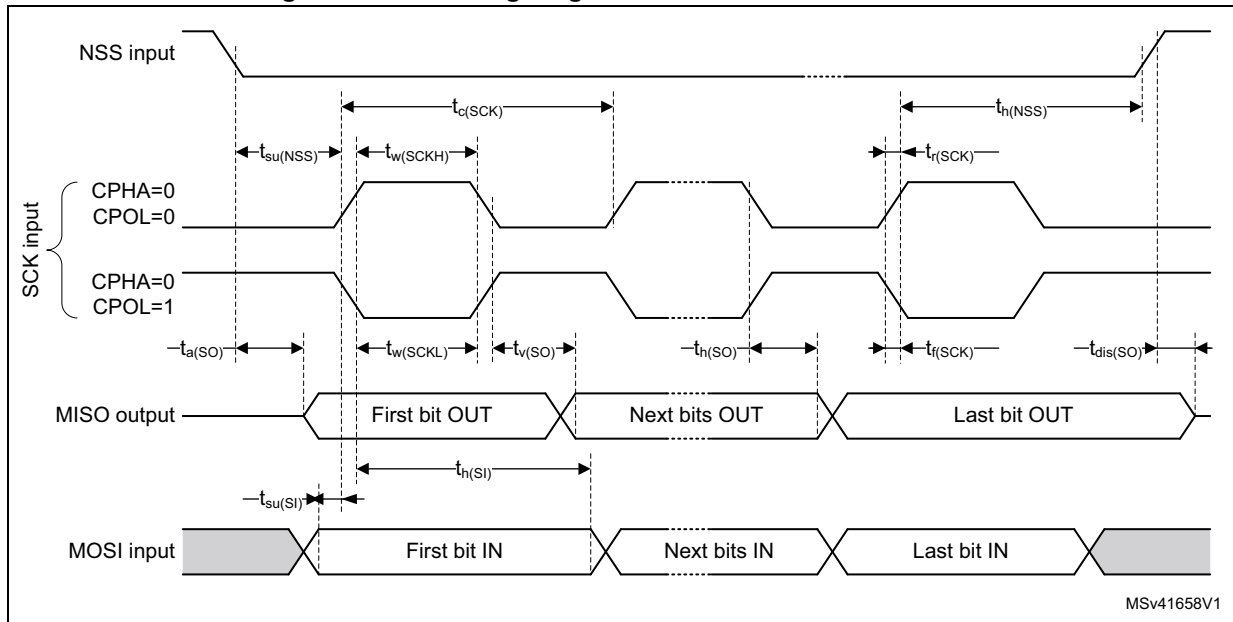
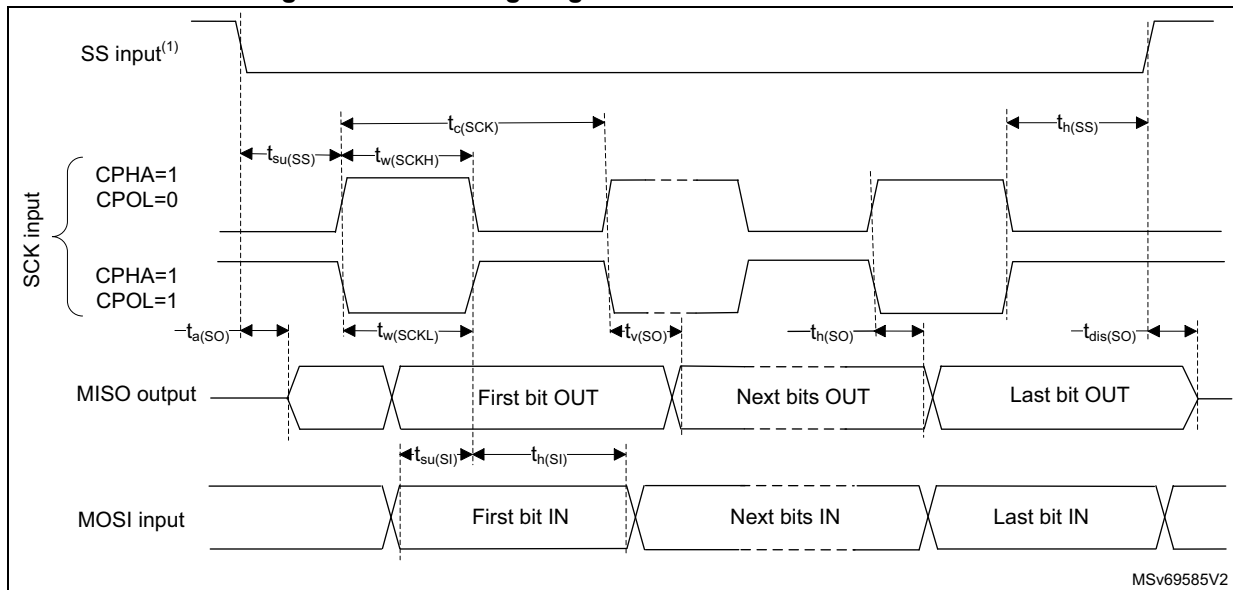

Figure 55. SPI timing diagram - Slave mode and CPHA = 1



1. The SS input can be configured to active low or active high.

I²S interface characteristics

Unless otherwise specified, the parameters given in [Table 112](#) are derived from tests performed under the ambient temperature, f_{PCLKx} frequency, and V_{DD} supply voltage conditions summarized in [Table 17](#), with the following configuration:

- Output speed is set to $OSPEEDRy[1:0] = 11$
- Capacitive load $C_L = 30 \text{ pF}$
- Measurement points are done at CMOS levels: $0.5 V_{DD}$
- I/O compensation cell activated

- HSLV activated when $V_{DD} \leq 2.7\text{ V}$
- VOS level set to VOS0

Refer to [Section 5.3.14](#) for more details on the input/output alternate function characteristics (CK,SD,WS).

Table 112. I²S dynamic characteristics⁽¹⁾

Symbol	Parameter	Conditions	Min	Max	Unit
f_{MCK}	I ² S main clock output	-	-	50	MHz
f_{CK}	I ² S clock output	Master transmitter	-	50	
		Slave transmitter (TX)	-	21	
		Slave receiver (RX)	-	50	
$t_{v(WS)}$	WS valid time	Master mode	-	2	ns
$t_{h(WS)}$	WS hold time		0.5	-	
$t_{su(WS)}$	WS setup time	Slave mode	3	-	
$t_{h(WS)}$	WS hold time		1.5	-	
$t_{su(SD_MR)}$	Data input setup time	Master receiver	4	-	
$t_{su(SD_SR)}$		Slave receiver	2	-	
$t_{h(SD_MR)}$	Data input hold time	Master receiver	1	-	
$t_{h(SD_SR)}$		Slave receiver	1.5	-	
$t_{v(SD_ST)}$	Data output valid time	Slave transmitter (after enable edge)	-	14	
$t_{v(SD_MT)}$		Master transmitter (after enable edge)	-	1	
$t_{h(SD_ST)}$	Data output hold time	Slave transmitter (after enable edge)	5.5	-	
$t_{h(SD_MT)}$		Master transmitter (after enable edge)	0	-	

1. Evaluated by characterization - Not tested in production.

Prerelease product(s)

Figure 56. I²S slave timing diagram (Philips protocol)⁽¹⁾

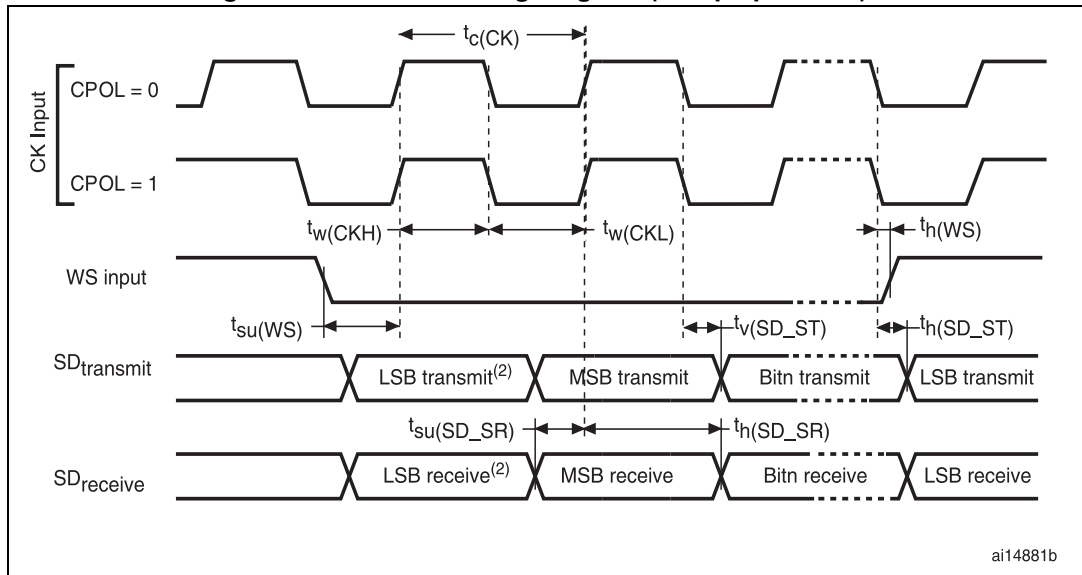

1. LSB transmit/receive of the previously transmitted byte. No LSB transmit/receive is sent before the first byte.

Figure 57. I²S master timing diagram (Philips protocol)⁽¹⁾

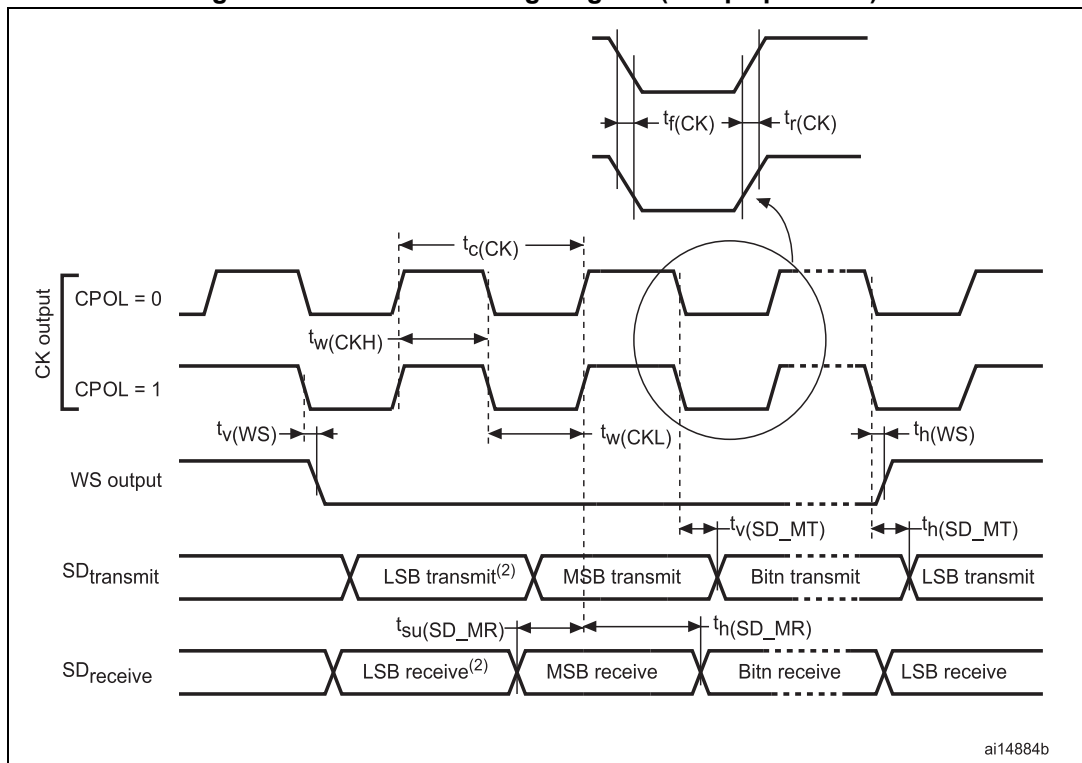

1. LSB transmit/receive of the previously transmitted byte. No LSB transmit/receive is sent before the first byte.

Prerelease product(s)

USB full speed (FS) characteristics

The USB interface is fully compliant with the USB specification version 2.0.

Table 113. USB DC electrical characteristics

Symbol	Parameter	Conditions	Min ⁽¹⁾	Typ	Max ⁽¹⁾	Unit
V _{DD}	USB full speed transceiver operating voltage	-	3.0 ⁽²⁾	3.3	3.6	V
V _{DI} ⁽³⁾	Differential input sensitivity	Over V _{CM} range	0.2	-	-	V
V _{CM} ⁽³⁾	Differential input common mode range	Includes V _{DI} range	0.8	-	2.5	
V _{SE} ⁽³⁾	Single ended receiver input threshold	-	0.8	-	2.0	
V _{OL}	Static output level low	R _L of 1.5 kΩ to 3.6 V ⁽⁴⁾	-	-	0.3	V
V _{OH}	Static output level high	R _L of 15 kΩ to V _{SS} ⁽⁴⁾	2.8	-	3.6	
R _{PD} ⁽⁴⁾	Pull down resistor on PA11, PA12 (USB_DP/DM)	V _{IN} = V _{DD}	14.25	-	24.8	kΩ
R _{PU} ⁽⁴⁾	Pull-up resistor on PA12 (USB_DP)	V _{IN} = V _{SS} , during idle	0.9	1.25	1.575	
	Pull-up resistor on PA12 (USB_DP)	V _{IN} = V _{SS} during reception	1.425	2.25	3.09	

1. All the voltages are measured from the local ground potential.
2. The USB full speed transceiver functionality is ensured down to 2.7 V but not the full USB full speed electrical characteristics, which are degraded in the 2.7-to-3.0 V V_{DD} voltage range.
3. Specified by design - Not tested in production.
4. R_L is the load connected on the USB full speed drivers.

Figure 58. USB timings - definition of data signal rise and fall time

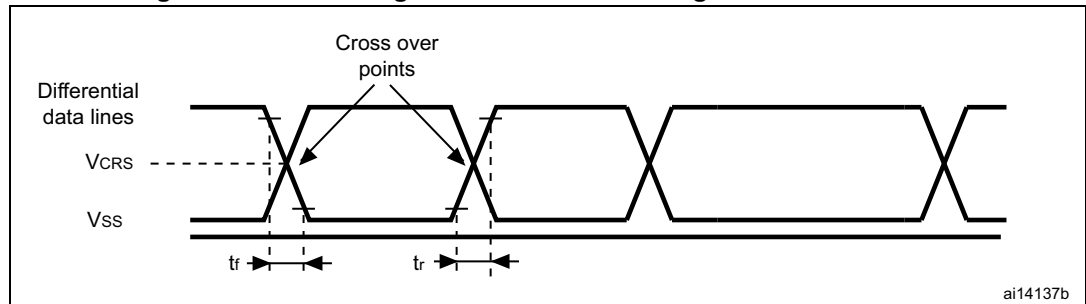

Table 114. USB startup time

Symbol	Parameter	Max	Unit
t _{STARTUP} ⁽¹⁾	USB transceiver startup time	1	μs

1. Specified by design - Not tested in production.

Table 115. USB electrical characteristics⁽¹⁾

Driver characteristics					
Symbol	Parameter	Conditions	Min	Max	Unit
t _{rLS}	Rise time in LS ⁽²⁾	C _L = 200 to 600 pF	75	300	ns
t _{fLS}	Fall time in LS ⁽²⁾	C _L = 200 to 600 pF	75	300	

Table 115. USB electrical characteristics⁽¹⁾ (continued)

Driver characteristics					
Symbol	Parameter	Conditions	Min	Max	Unit
t _{rfmLS}	Rise/fall time matching in LS	t _r /t _f	80	125	%
t _{rFS}	Rise time in FS ⁽²⁾	C _L = 50 pF	4	20	ns
t _{fFS}	Fall time in FS ⁽²⁾	C _L = 50 pF	4	20	
t _{rfmFS}	Rise/fall time matching in FS	t _r /t _f	90	111	%
V _{CRS}	Output signal crossover voltage (LS/FS)	-	1.3	2.0	V
Z _{DRV}	Output driver impedance ⁽³⁾	Driving high or low	28	44	Ω

1. Specified by design - Not tested in production.
2. Measured from 10% to 90% of the data signal. For more detailed information, refer to USB specification - chapter 7 (version 2.0).
3. No external termination series resistors are required on DP (D+) and DM (D-) pins since the matching impedance is included in the embedded driver.

Table 116. USB BCD DC electrical characteristics⁽¹⁾

Symbol	Parameter	Conditions	Min	Typ	Max	Unit
I _{DD(USBBCD)}	Primary detection mode consumption	-	-	-	300	μA
	Secondary detection mode consumption	-	-	-	300	
R _{DAT_LKG}	Data line leakage resistance	-	300	-	-	kΩ
V _{DAT_LKG}	Data line leakage voltage	-	0.0	-	3.6	V
R _{DCP_DAT}	Dedicated charging port resistance across D+/D-	-	-	-	200	Ω
V _{LGC_HI}	Logic high	-	2.0	-	3.6	V
V _{LGC_LOW}	Logic low	-	-	-	0.8	
V _{LGC}	Logic threshold	-	0.8	-	2.0	
V _{DAT_REF}	Data detect voltage	-	0.25	-	0.4	
V _{DP_SRC}	D+ source voltage	-	0.5	-	0.7	
V _{DM_SRC}	D- source voltage	-	0.5	-	0.7	
I _{DP_SINK}	D+ sink current	-	25	-	175	μA
I _{DM_SINK}	D- sink current	-	25	-	175	

1. Specified by design - Not tested in production.

UCPD characteristics

The UCPD controller complies with USB Type-C Rev 1.2 and USB Power Delivery Rev 3.0 specifications.

Table 117. UCPD electrical characteristics

Symbol	Parameter	Condition	Min	Typ	Max	Unit
V _{DD}	UCPD operating supply voltage	-	3.0	3.3	3.6	mA
V _{swing}	Output voltage swing	-	1.05	-	1.2	V
Z _{DRV}	Output driver impedance	-	33	-	75	Ω

SD/SDIO MMC card host interface (SDMMC) characteristics

Unless otherwise specified, the parameters given in [Table 118](#) and [Table 119](#) are derived from tests performed under the ambient temperature, f_{PCLKx} frequency, and V_{DD} supply voltage summarized in [Table 17](#), with the following configuration:

- Output speed is set to OSPEEDRy[1:0] = 11
- Capacitive load C_L = 30 pF
- Measurement points are done at CMOS levels: 0.5 V_{DD}
- I/O compensation cell activated
- HSLV activated when V_{DD} ≤ 2.7 V

Refer to [Section 5.3.14](#) for more details on the input/output characteristics.

Table 118. Dynamic characteristics: SD/MMC, V_{DD} = 2.7 to 3.6 V⁽¹⁾

Symbol	Parameter	Conditions	Min	Typ	Max	Unit
f _{PP}	Clock frequency in data transfer mode	-	0	-	130 ⁽²⁾ /104 ⁽²⁾ (3)	MHz
t _{W(CKL)}	Clock low time	f _{PP} = 52 MHz	8.5	9.5	-	ns
t _{W(CKH)}	Clock high time		8.5	9.5	-	
CMD, D inputs (referenced to CK) in eMMC legacy/SDR/DDR and SD HS/SDR⁽⁴⁾/DDR⁽⁴⁾ mode						
t _{ISU}	Input setup time HS	-	3	-	-	ns
t _{IH}	Input hold time HS	-	2	-	-	
t _{IDW⁽⁵⁾}	Input valid window (variable window)	-	4.5	-	-	
CMD, D outputs (referenced to CK) in eMMC legacy/SDR/DDR and SD HS/SDR⁽⁴⁾/DDR⁽⁴⁾ mode						
t _{OV}	Output valid time HS	-	-	(Tker / 2) + 1	(Tker / 2) + 1.5	ns
t _{OH}	Output hold time HS	-	(Tker / 2) - 0.5	-	-	
CMD, D inputs (referenced to CK) in SD default mode						
t _{ISUD}	Input setup time SD	-	3	-	-	ns
t _{IHD}	Input hold time SD	-	2	-	-	
CMD, D outputs (referenced to CK) in SD default mode						
t _{OVD}	Output valid default time SD	-	-	1	2	ns
t _{OHD}	Output hold default time SD	-	0	-	-	

Prerelease product(s)



1. Evaluated by characterization - Not tested in production.
2. C_L applied is 20 pF.
3. Maximum speed for LQFP100 package.
4. For SD 1.8 V support, an external voltage converter is needed.
5. The minimum window of time where the data needs to be stable for proper sampling in tuning mode.

Table 119. Dynamic characteristics: eMMC, $V_{DD} = 1.71$ to 1.9 V⁽¹⁾

Symbol	Parameter	Conditions	Min	Typ	Max	Unit
f_{PP}	Clock frequency in data transfer mode	-	0	-	110 ⁽²⁾ /88 ⁽³⁾	MHz
$t_{W(CKL)}$	Clock low time	$f_{PP} = 52$ MHz	8.5	9.5	-	ns
$t_{W(CKH)}$	Clock high time		8.5	9.5	-	
CMD, D inputs (referenced to CK) in eMMC mode						
t_{ISU}	Input setup time HS	-	2	-	-	ns
t_{IH}	Input hold time HS	-	2	-	-	
$t_{IDW}^{(4)}$	Input valid window (variable window)	-	4	-	-	
CMD, D outputs (referenced to CK) in eMMC mode						
t_{OV}	Output valid time HS	-	-	$(T_{ker} / 2) + 1$	$(T_{ker} / 2) + 1.5$	ns
t_{OH}	Output hold time HS	-	$(T_{ker} / 2) - 0.5$	-	-	

1. Evaluated by characterization - Not tested in production.
2. $C_L = 20$ pF.
3. Maximum speed for LQFP100 package.
4. The minimum window of time where the data needs to be stable for proper sampling in tuning mode.

Prerelease product(s)

Prerelease product(s)

Figure 59. SDIO high-speed/eMMC timing

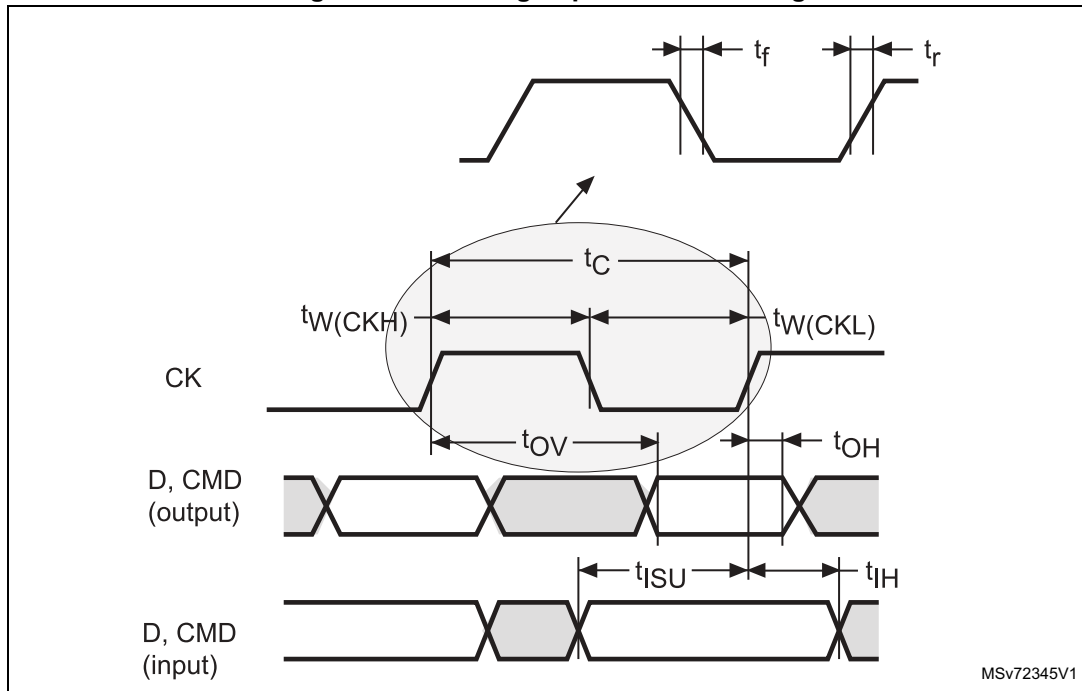

Figure 60. SD default speed timings

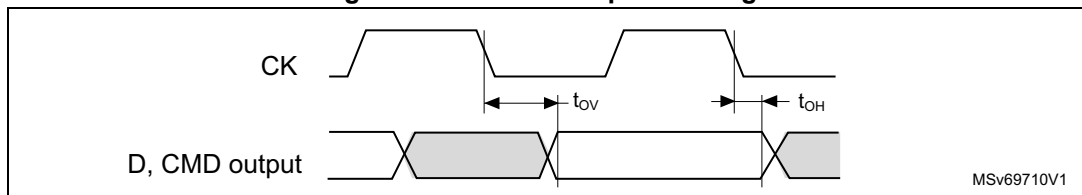
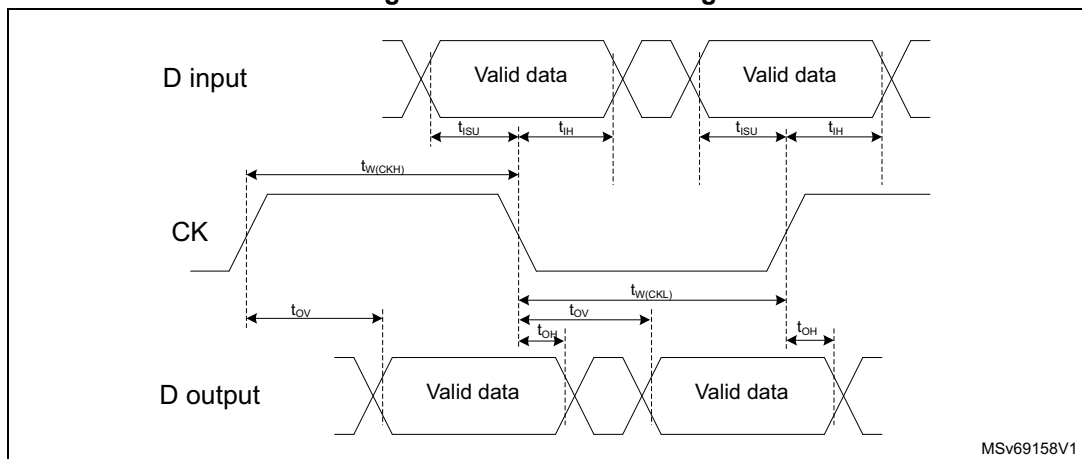

Figure 61. DDR mode timings



Ethernet interface characteristics

Unless otherwise specified, the parameters given in [Table 120](#), [Table 121](#), and [Table 122](#) are derived from tests performed under the ambient temperature, $f_{\text{RCC_C_CK}}$ frequency, and V_{DD} supply voltage conditions summarized in [Table 17](#), with the following configuration:

- Output speed is set to OSPEEDRy[1:0] = 10
- Capacitive load $C_L = 20$ pF
- Measurement points are done at CMOS levels: $0.5 V_{\text{DD}}$
- I/O compensation cell activated
- HSLV activated when $V_{\text{DD}} \leq 2.7$ V

Refer to [Section 5.3.14](#) for more details on the input/output characteristics.

Table 120. Dynamic characteristics: Ethernet MAC signals for SMI ⁽¹⁾

Symbol	Parameter	Min	Typ	Max	Unit
t_{MDC}	MDC cycle time (2.5 MHz)	398	400	402	ns
$T_{\text{d(MDIO)}}$	Write data valid time	0	1.5	2	
$t_{\text{su(MDIO)}}$	Read data setup time	12.5	-	-	
$t_{\text{h(MDIO)}}$	Read data hold time	0	-	-	

1. Evaluated by characterization - Not tested in production.

Table 121. Dynamic characteristics: Ethernet MAC signals for RMII ⁽¹⁾

Symbol	Parameter	Min	Typ	Max	Unit
$t_{\text{su(RXD)}}$	Receive data setup time	3	-	-	ns
$t_{\text{ih(RXD)}}$	Receive data hold time	1	-	-	
$t_{\text{su(CRS)}}$	Carrier sense setup time	2	-	-	
$t_{\text{ih(CRS)}}$	Carrier sense hold time	1	-	-	
$t_{\text{d(TXEN)}}$	Transmit enable valid delay time	7	9.5	15	
$t_{\text{d(TXD)}}$	Transmit data valid delay time	7	10	15.5	

1. Evaluated by characterization - Not tested in production.

Table 122. Dynamic characteristics: Ethernet MAC signals for MII ⁽¹⁾

Symbol	Parameter	Min	Typ	Max	Unit
$t_{\text{su(RXD)}}$	Receive data setup time	3	-	-	ns
$t_{\text{ih(RXD)}}$	Receive data hold time	1.5	-	-	
$t_{\text{su(DV)}}$	Data valid setup time	2	-	-	
$t_{\text{ih(DV)}}$	Data valid hold time	1	-	-	
$t_{\text{su(ER)}}$	Error setup time	3	-	-	
$t_{\text{ih(ER)}}$	Error hold time	1	-	-	
$t_{\text{d(TXEN)}}$	Transmit enable valid delay time	7	10	16	
$t_{\text{d(TXD)}}$	Transmit data valid delay time	7.5	10.5	16.5	

Prerelease product(s)

1. Evaluated by characterization - Not tested in production.

Figure 62. Ethernet RMIi timing diagram

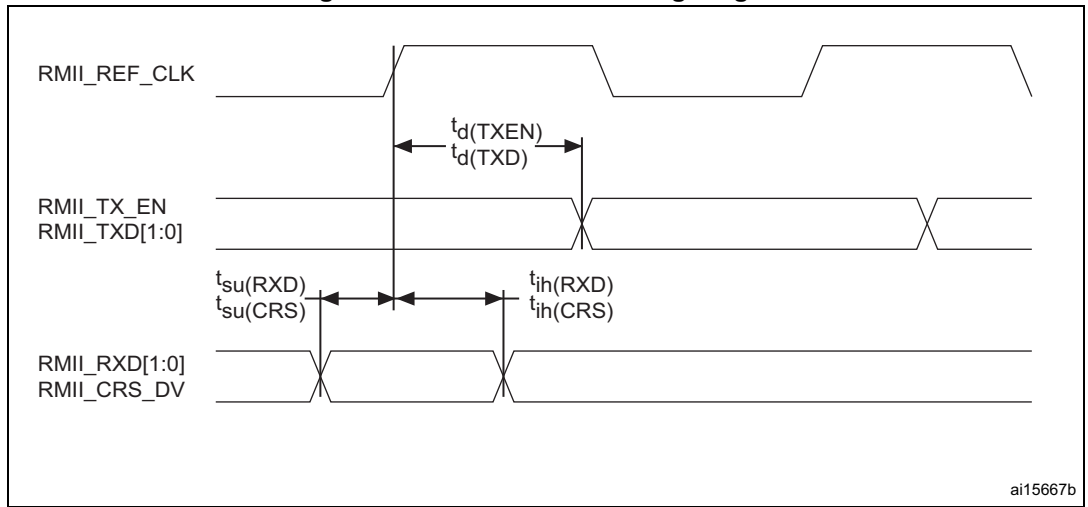
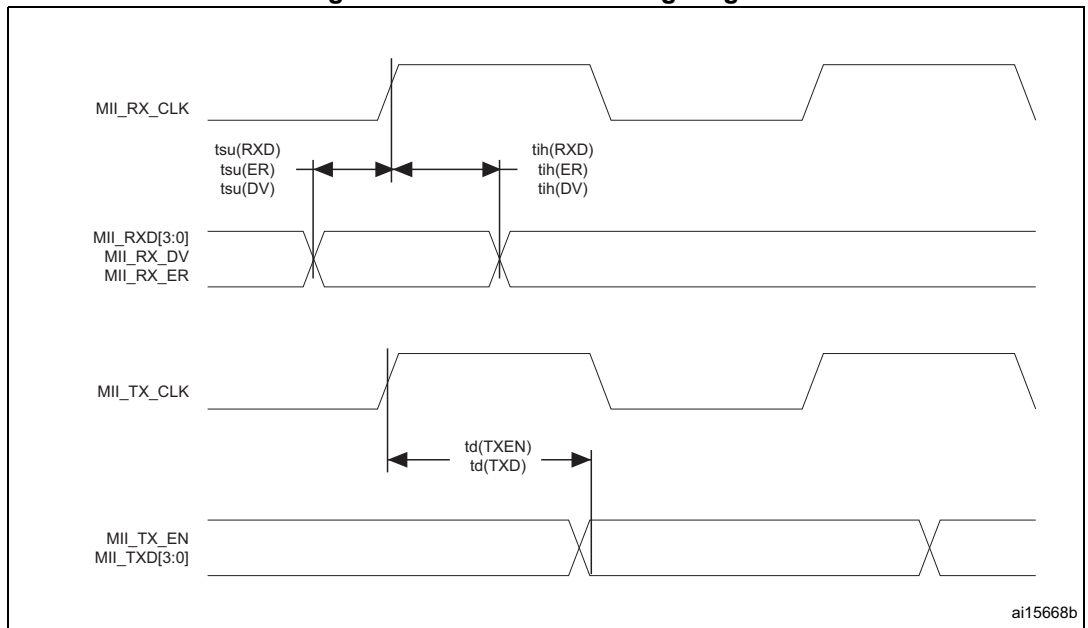
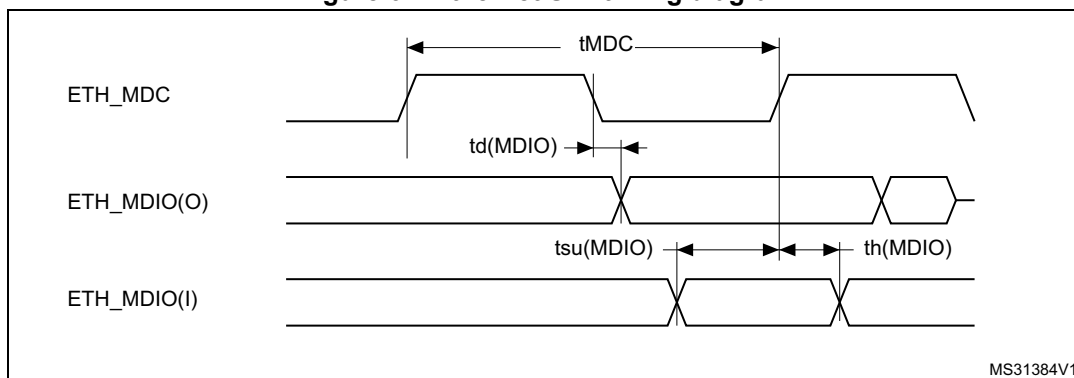

Figure 63. Ethernet MII timing diagram



Prerelease product(s)

Figure 64. Ethernet SMI timing diagram



MS31384V1

JTAG/SWD interface characteristics

Unless otherwise specified, the parameters given in Table 123 and Table 124 for JTAG/SWD are derived from tests performed under the ambient temperature, $f_{rcc_c_ck}$ frequency, and V_{DD} supply voltage summarized in Table 17, with the following configuration:

- Output speed is set to OSPEEDRy[1:0] = 11
- Capacitive load $C_L = 30$ pF
- HSLV activated when $V_{DD} \leq 2.7$ V
- Measurement points are done at CMOS levels: $0.5 V_{DD}$

Refer to Section 5.3.14 for more details on the input/output characteristics.

Table 123. Dynamic JTAG characteristics

Symbol	Parameter	Conditions	Min	Typ	Max	Unit
F_{TCK}	TCK clock frequency	$2.7\text{ V} < V_{DD} < 3.6\text{ V}$	-	-	50	MHz
$1/t_c(TCK)$		$1.71\text{ V} < V_{DD} < 3.6\text{ V}$	-	-	45	
$t_{i_{su}}(TMS)$	TMS input setup time	-	3.5	-	-	ns
$t_{i_h}(TMS)$	TMS input hold time	-	1.5	-	-	
$t_{i_{su}}(TDI)$	TDI input setup time	-	2.5	-	-	
$t_{i_h}(TDI)$	TDI input hold time	-	1.5	-	-	
$t_{ov}(TDO)$	TDO output valid time	$2.7\text{ V} < V_{DD} < 3.6\text{ V}$	-	8	10	
		$1.71\text{ V} < V_{DD} < 3.6\text{ V}$	-	8	11	
$t_{oh}(TDO)$	TDO output hold time	-	6.5	-	-	

Table 124. Dynamic SWD characteristics

Symbol	Parameter	Conditions	Min	Typ	Max	Unit
F_{SWCLK}	SWCLK clock frequency	$2.7\text{ V} < V_{DD} < 3.6\text{ V}$	-	-	80	MHz
$1/t_c(SWCLK)$		$1.71\text{ V} < V_{DD} < 3.6\text{ V}$	-	-	71	

Table 124. Dynamic SWD characteristics (continued)

Symbol	Parameter	Conditions	Min	Typ	Max	Unit
$t_{i_{su}(SWDIO)}$	SWDIO input setup time	-	1.5	-	-	ns
$t_{i_h}(SWDIO)$	SWDIO input hold time	-	1.5	-	-	
$t_{ov}(SWDIO)$	SWDIO output valid time	$2.7\text{ V} < V_{DD} < 3.6\text{ V}$	-	10.5	12.5	
		$1.71\text{ V} < V_{DD} < 3.6\text{ V}$	-	10.5	14.0	
$t_{oh}(SWDIO)$	SWDIO output hold time	-	8.5	-	-	

Figure 65. JTAG timing diagram

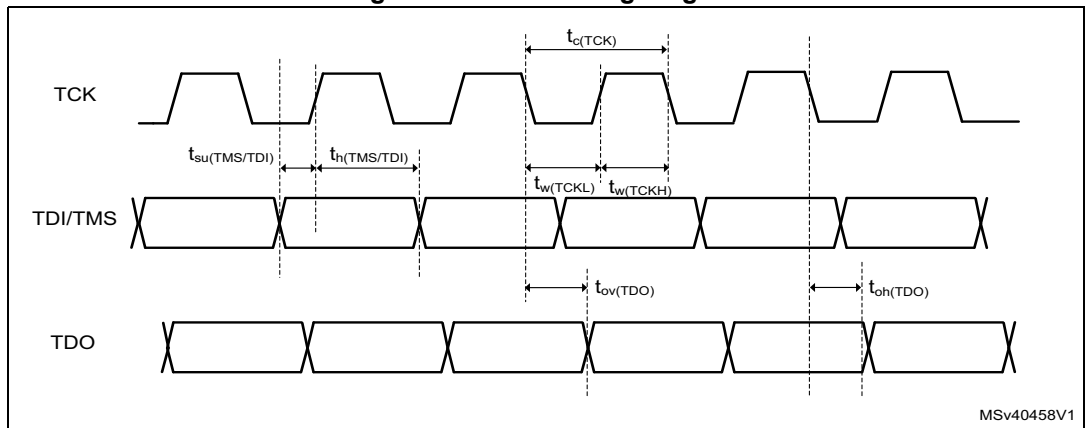

MSv40458V1

Figure 66. SWD timing diagram

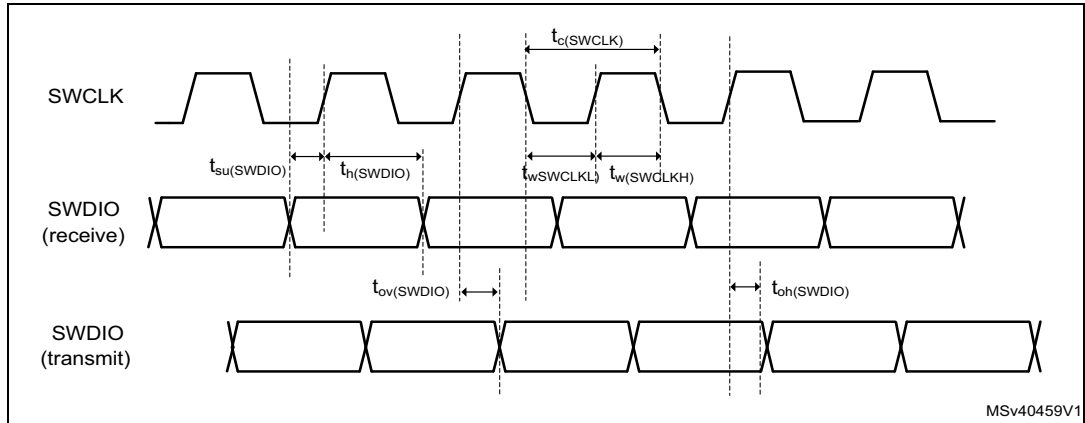

MSv40459V1

Prerelease product(s)

6 Package information

To meet environmental requirements, ST offers these devices in different grades of ECOPACK packages, depending on their level of environmental compliance. ECOPACK specifications, grade definitions and product status are available at: www.st.com. ECOPACK is an ST trademark.

6.1 Device marking

Refer to “*Reference device marking schematics for STM32 microcontrollers and microprocessors*” (TN1433), available on www.st.com, for the location of pin 1 / ball A1 as well as the location and orientation of the marking areas versus pin 1 / ball A1.

Parts marked as “ES”, “E” or accompanied by an engineering sample notification letter, are not yet qualified and therefore not approved for use in production. ST is not responsible for any consequences resulting from such use. In no event will ST be liable for the customer using any of these engineering samples in production. ST's Quality department must be contacted prior to any decision to use these engineering samples to run a qualification activity.

A WLCSP simplified marking example (if any) is provided in the corresponding package information subsection.

6.2 LQFP48 package information (5B)

This LQFP is a 48-pin, 7 x 7 mm low-profile quad flat package.

Note: See list of notes in the notes section.

Figure 67. LQFP48 - Outline⁽¹⁵⁾

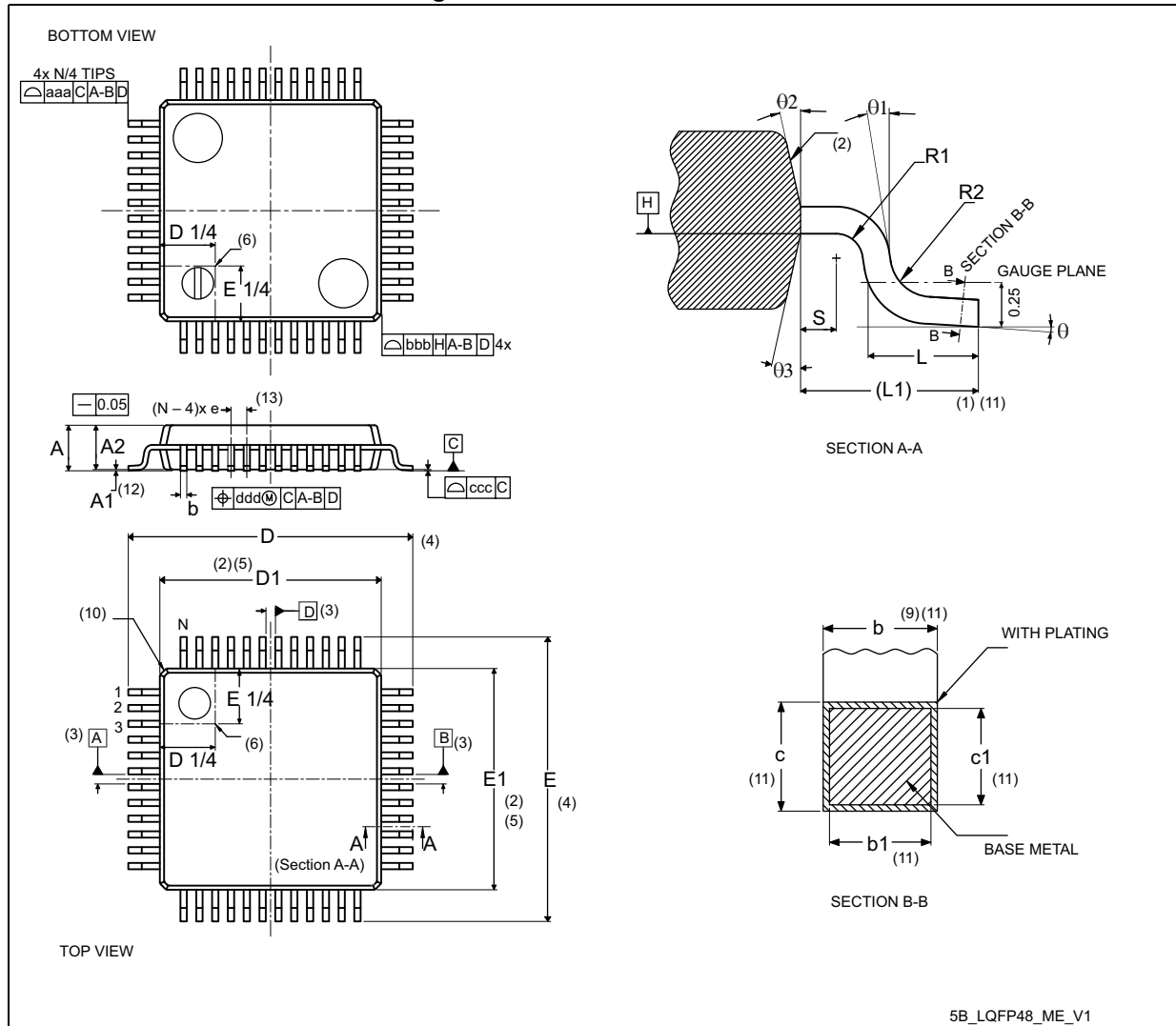

Prerelease product(s)

Table 125. LQFP48 - Mechanical data

Symbol	millimeters			inches ⁽¹⁴⁾		
	Min	Typ	Max	Min	Typ	Max
A	-	-	1.60	-	-	0.0630
A1 ⁽¹²⁾	0.05	-	0.15	0.0020	-	0.0059
A2	1.35	1.40	1.45	0.0531	0.0551	0.0571
b ⁽⁹⁾⁽¹¹⁾	0.17	0.22	0.27	0.0067	0.0087	0.0106
b1 ⁽¹¹⁾	0.17	0.20	0.23	0.0067	0.0079	0.0090
c ⁽¹¹⁾	0.09	-	0.20	0.0035	-	0.0079
c1 ⁽¹¹⁾	0.09	-	0.16	0.0035	-	0.0063
D ⁽⁴⁾	9.00 BSC			0.3543 BSC		
D1 ⁽²⁾⁽⁵⁾	7.00 BSC			0.2756 BSC		
E ⁽⁴⁾	9.00 BSC			0.3543 BSC		
E1 ⁽²⁾⁽⁵⁾	7.00 BSC			0.2756 BSC		
e	0.50 BSC			0.1970 BSC		
L	0.45	0.60	0.75	0.0177	0.0236	0.0295
L1	1.00 REF			0.0394 REF		
N ⁽¹³⁾	48					
θ	0°	3.5°	7°	0°	3.5°	7°
θ1	0°	-	-	0°	-	-
θ2	10°	12°	14°	10°	12°	14°
θ3	10°	12°	14°	10°	12°	14°
R1	0.08	-	-	0.0031	-	-
R2	0.08	-	0.20	0.0031	-	0.0079
S	0.20	-	-	0.0079	-	-
aaa ⁽¹⁾⁽⁷⁾	0.20			0.0079		
bbb ⁽¹⁾⁽⁷⁾	0.20			0.0079		
ccc ⁽¹⁾⁽⁷⁾	0.08			0.0031		
ddd ⁽¹⁾⁽⁷⁾	0.08			0.0031		

Notes:

1. Dimensioning and tolerancing schemes conform to ASME Y14.5M-1994.
2. The top package body size may be smaller than the bottom package size by as much as 0.15 mm.
3. Datums A-B and D to be determined at datum plane H.
4. To be determined at seating datum plane C.
5. Dimensions D1 and E1 do not include mold flash or protrusions. Allowable mold flash or protrusions is 0.25 mm per side. D1 and E1 are maximum plastic body size dimensions including mold mismatch.
6. Details of pin 1 identifier are optional but must be located within the zone indicated.
7. All dimensions are in millimeters.
8. No intrusion allowed inwards the leads.
9. Dimension “b” does not include dambar protrusion. Allowable dambar protrusion shall not cause the lead width to exceed the maximum “b” dimension by more than 0.08 mm. Dambar cannot be located on the lower radius or the foot. Minimum space between protrusion and an adjacent lead is 0.07 mm for 0.4 mm and 0.5 mm pitch packages.
10. Exact shape of each corner is optional.
11. These dimensions apply to the flat section of the lead between 0.10 mm and 0.25 mm from the lead tip.
12. A1 is defined as the distance from the seating plane to the lowest point on the package body.
13. “N” is the number of terminal positions for the specified body size.
14. Values in inches are converted from mm and rounded to four decimal digits.
15. Drawing is not to scale.

Figure 68. LQFP48 - Footprint example

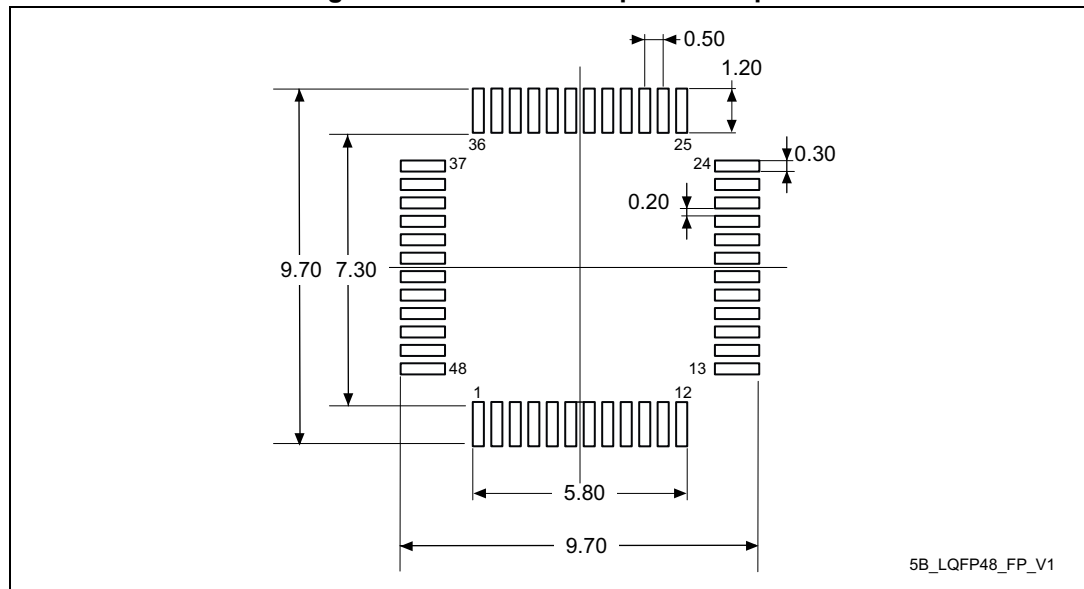

1. Dimensions are expressed in millimeters.

Prerelease product(s)

6.3 UFQFPN48 package information (A0B9)

This UFQFPN is a 48-lead, 7 x 7 mm, 0.5 mm pitch, ultra thin fine pitch quad flat package.

Figure 69. UFQFPN48 - Outline

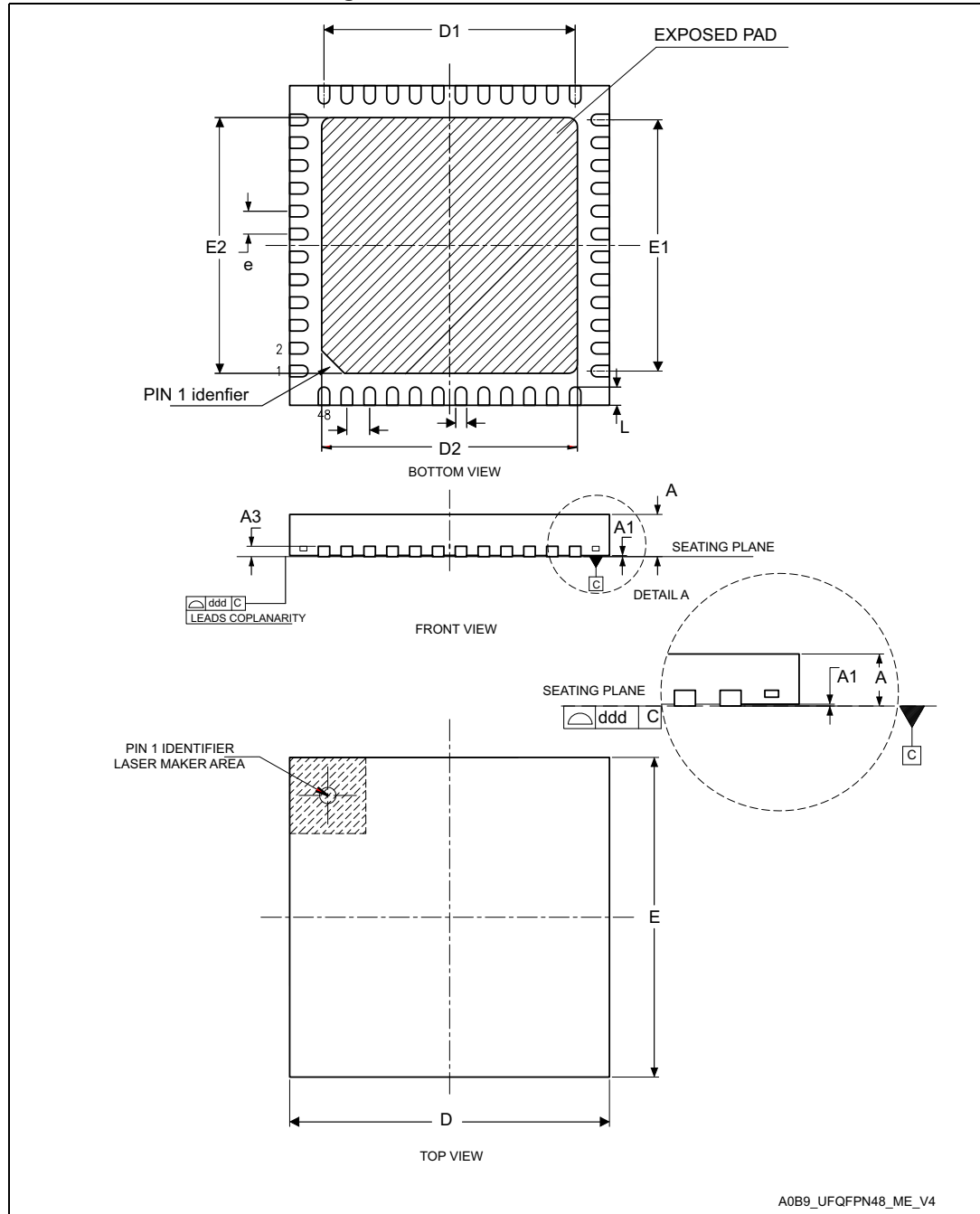

1. Drawing is not to scale.
2. All leads/pads should also be soldered to the PCB to improve the lead/pad solder joint life.
3. There is an exposed die pad on the underside of the UFQFPN48 package. It is recommended to connect and solder this back-side pad to PCB ground.

Prerelease product(s)

6.4 WLCSP63 package information (C02A)

This WLCSP is a 63-ball, 3.01 x 2.97 mm, 0.35 mm pitch, wafer level chip scale package.

Figure 71. WLCSP63 - Outline

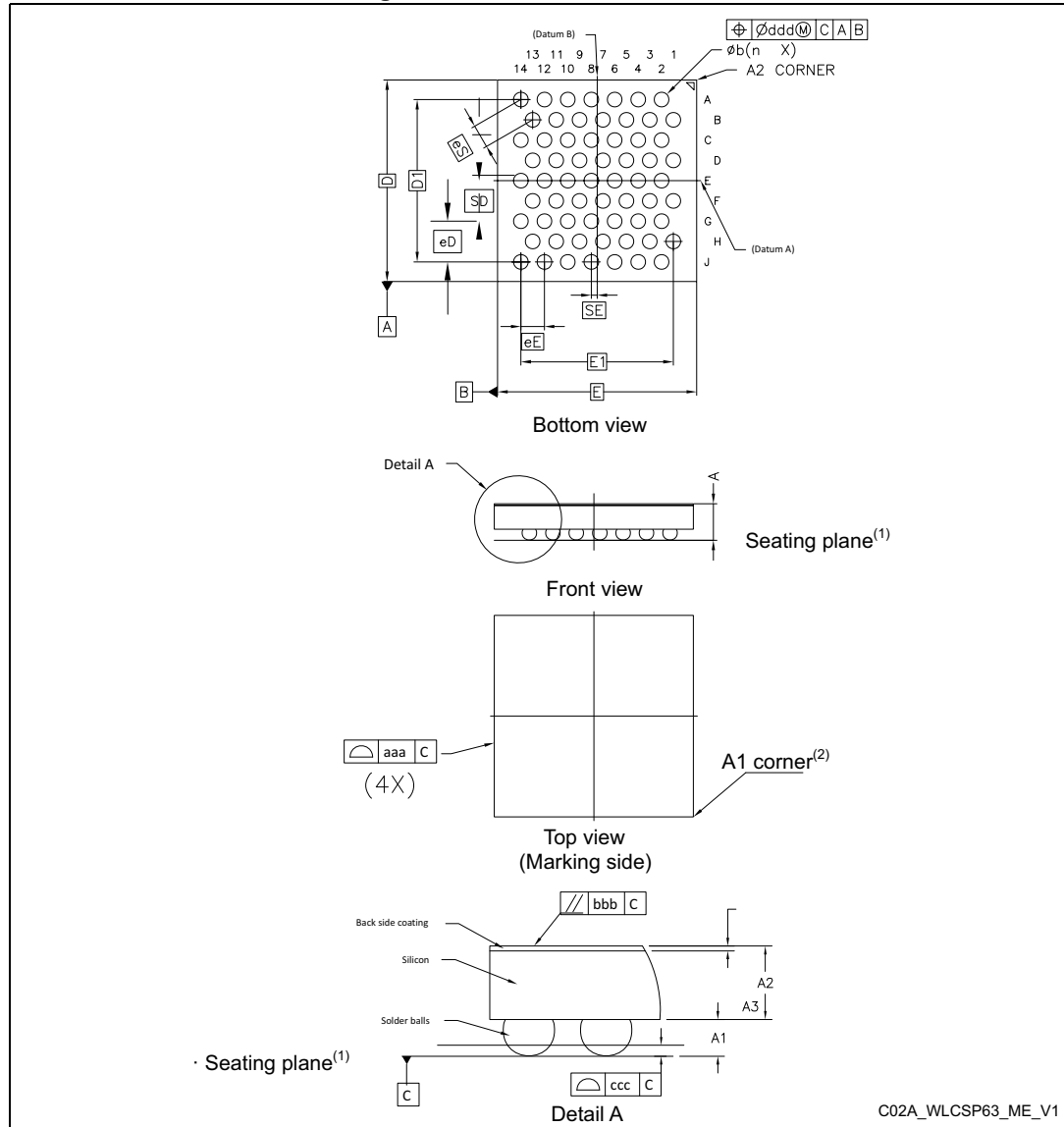

1. Datum C (seating plane) is defined by the plane established by the contact points of three or more solder balls that support the device when it is placed on top of a planar surface.
2. The A1 corner is identified on the top surface of the package by using a marking or a physical feature. A distinguish feature is allowable on the bottom surface of the package to identify the A1 corner. Exact shape of each corner is optional.
3. Drawing is not to scale.

Prerelease product(s)

Table 127. WLCSP63 - Mechanical data

Symbol	millimeters			inches ⁽¹⁾		
	Min	Typ	Max	Min	Typ	Max
A ⁽²⁾	-	-	0.58	-	-	0.0228
A1 ⁽³⁾	0.12	-	-	0.0047	-	-
A2	-	0.38	-	-	0.0150	-
A3	-	0.025	-	-	0.0010	-
b ⁽⁴⁾	0.19	0.23	0.26	0.0075	0.0091	0.0102
D ⁽⁵⁾	-	3.01 BSC	-	-	0.1185 BSC	-
D1 ⁽⁵⁾	-	2.43 BSC	-	-	0.0957 BSC	-
E ⁽⁵⁾	-	2.97 BSC	-	-	0.1169 BSC	-
E1 ⁽⁵⁾	-	2.28 BSC	-	-	0.0898 BSC	-
eD ⁽⁵⁾⁽⁶⁾	-	0.61 BSC	-	-	0.0240 BSC	-
eE ⁽⁵⁾⁽⁶⁾	-	0.35 BSC	-	-	0.0138 BSC	-
eS ⁽⁵⁾⁽⁶⁾	-	0.35 BSC	-	-	0.0138 BSC	-
SD ⁽⁵⁾⁽⁷⁾	-	0.61 BSC	-	-	0.0240 BSC	-
SE ⁽⁵⁾⁽⁷⁾	-	0.09 BSC	-	-	0.0035 BSC	-
Tolerance of form and position						
aaa ⁽⁸⁾	0.02			0.0008		
bbb ⁽⁸⁾	0.06			0.0024		
ccc ⁽⁸⁾	0.03			0.0012		
ddd ⁽⁸⁾	0.015			0.0006		

1. Values in inches are converted from mm and rounded to four decimal digits.
2. The profile height (A) is the distance from the seating plane to the highest point on the package. It is measured perpendicular to the seating plane.
3. A1 is defined as the distance from the seating plane to the lowest point on the package body.
4. Dimension b is measured at the maximum diameter of the terminal (ball) in a plane parallel to Datum C.
5. BSC stands for BASIC dimensions. It corresponds to the nominal value and has no linear tolerance. For tolerances refer to form and position table. On the drawing these dimensions are framed.
6. eD represents the solder balls grid pitch(es).
7. Basic dimensions SD & SE are defining the ball matrix position with respect to datums A and B.
8. Tolerance of form and position drawing.

Table 128. LQFP64 - Mechanical data

Symbol	millimeters			inches ⁽¹⁴⁾		
	Min	Typ	Max	Min	Typ	Max
A	-	-	1.60	-	-	0.0630
A1 ⁽¹²⁾	0.05	-	0.15	0.0020	-	0.0059
A2	1.35	1.40	1.45	0.0531	0.0551	0.0570
b ⁽⁹⁾⁽¹¹⁾	0.17	0.22	0.27	0.0067	0.0087	0.0106
b1 ⁽¹¹⁾	0.17	0.20	0.23	0.0067	0.0079	0.0091
c ⁽¹¹⁾	0.09	-	0.20	0.0035	-	0.0079
c1 ⁽¹¹⁾	0.09	-	0.16	0.0035	-	0.0063
D ⁽⁴⁾	12.00 BSC			0.4724 BSC		
D1 ⁽²⁾⁽⁵⁾	10.00 BSC			0.3937 BSC		
E ⁽⁴⁾	12.00 BSC			0.4724 BSC		
E1 ⁽²⁾⁽⁵⁾	10.00 BSC			0.3937 BSC		
e	0.50 BSC			0.1970 BSC		
L	0.45	0.60	0.75	0.0177	0.0236	0.0295
L1	1.00 REF			0.0394 REF		
N ⁽¹³⁾	64					
θ	0°	3.5°	7°	0°	3.5°	7°
θ1	0°	-	-	0°	-	-
θ2	10°	12°	14°	10°	12°	14°
θ3	10°	12°	14°	10°	12°	14°
R1	0.08	-	-	0.0031	-	-
R2	0.08	-	0.20	0.0031	-	0.0079
S	0.20	-	-	0.0079	-	-
aaa ⁽¹⁾	0.20			0.0079		
bbb ⁽¹⁾	0.20			0.0079		
ccc ⁽¹⁾	0.08			0.0031		
ddd ⁽¹⁾	0.08			0.0031		

Notes:

1. Dimensioning and tolerancing schemes conform to ASME Y14.5M-1994.
2. The top package body size may be smaller than the bottom package size by as much as 0.15 mm.
3. Datums A-B and D to be determined at datum plane H.
4. To be determined at seating datum plane C.
5. Dimensions D1 and E1 do not include mold flash or protrusions. Allowable mold flash or protrusions is 0.25 mm per side. D1 and E1 are maximum plastic body size dimensions including mold mismatch.
6. Details of pin 1 identifier are optional but must be located within the zone indicated.
7. All dimensions are in millimeters.
8. No intrusion allowed inwards the leads.
9. Dimension “b” does not include dambar protrusion. Allowable dambar protrusion shall not cause the lead width to exceed the maximum “b” dimension by more than 0.08 mm. Dambar cannot be located on the lower radius or the foot. Minimum space between protrusion and an adjacent lead is 0.07 mm for 0.4 mm and 0.5 mm pitch packages.
10. Exact shape of each corner is optional.
11. These dimensions apply to the flat section of the lead between 0.10 mm and 0.25 mm from the lead tip.
12. A1 is defined as the distance from the seating plane to the lowest point on the package body.
13. “N” is the number of terminal positions for the specified body size.
14. Values in inches are converted from mm and rounded to four decimal digits.
15. Drawing is not to scale.

Figure 73. LQFP64 - Footprint example

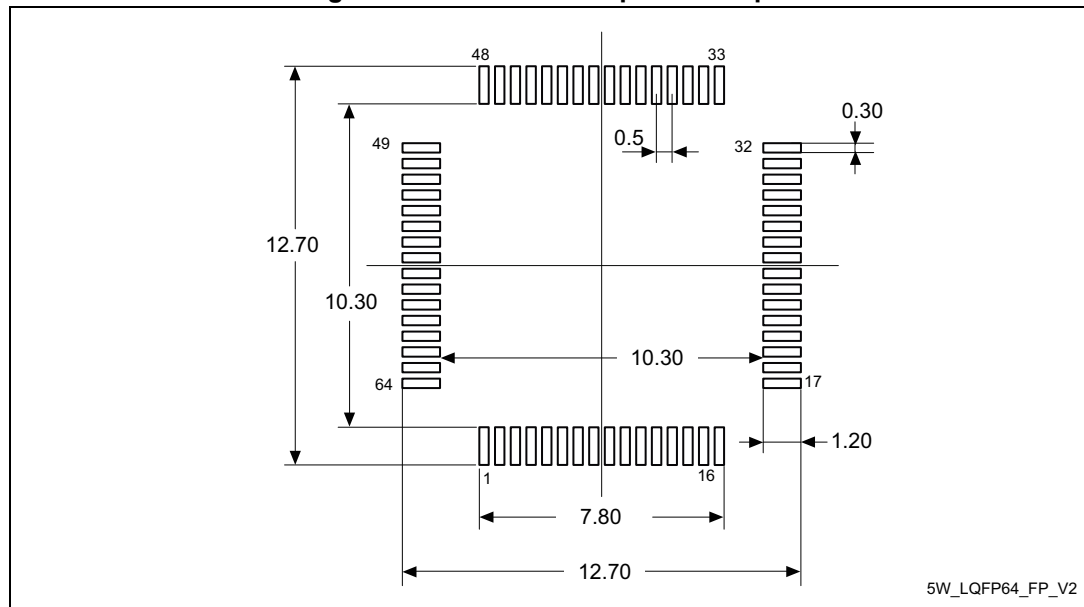

1. Dimensions are expressed in millimeters.

Prerelease product(s)

6.6 LQFP100 package information (1L)

This LQFP is a 100 lead, 14 x 14 mm low-profile quad flat package.

Note: See list of notes in the notes section.

Figure 74. LQFP100 - Outline⁽¹⁵⁾

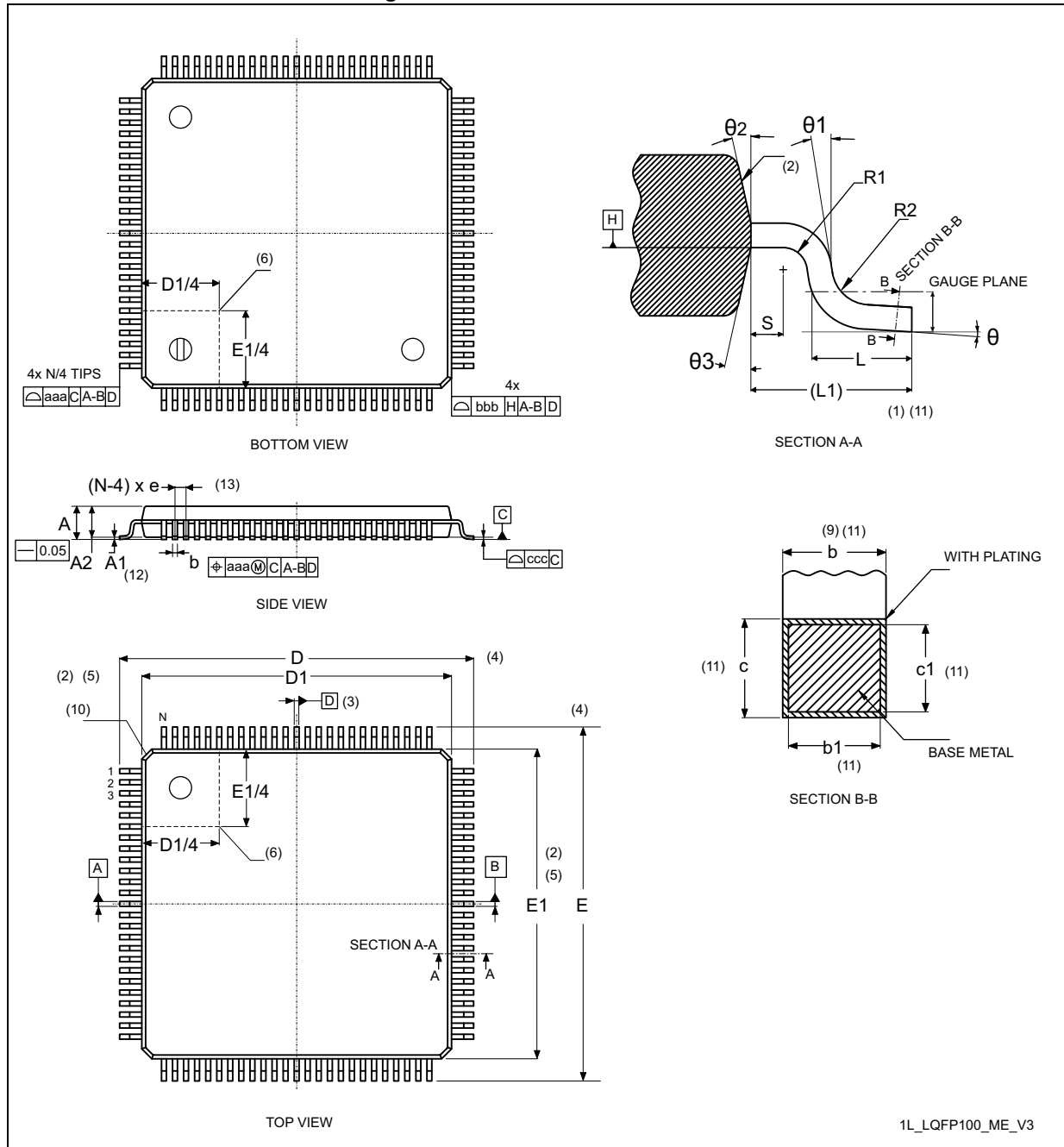

Prerelease product(s)

Table 129. LQFP100 - Mechanical data

Symbol	Millimeters			Inches ⁽¹⁴⁾		
	Min	Typ	Max	Min	Typ	Max
A	-	1.50	1.60	-	0.0590	0.0630
A1 ⁽¹²⁾	0.05	-	0.15	0.0019	-	0.0059
A2	1.35	1.40	1.45	0.0531	0.0551	0.0570
b ⁽⁹⁾⁽¹¹⁾	0.17	0.22	0.27	0.0067	0.0087	0.0106
b1 ⁽¹¹⁾	0.17	0.20	0.23	0.0067	0.0079	0.0090
c ⁽¹¹⁾	0.09	-	0.20	0.0035	-	0.0079
c1 ⁽¹¹⁾	0.09	-	0.16	0.0035	-	0.0063
D ⁽⁴⁾	16.00 BSC			0.6299 BSC		
D1 ⁽²⁾⁽⁵⁾	14.00 BSC			0.5512 BSC		
E ⁽⁴⁾	16.00 BSC			0.6299 BSC		
E1 ⁽²⁾⁽⁵⁾	14.00 BSC			0.5512 BSC		
e	0.50 BSC			0.0197 BSC		
L	0.45	0.60	0.75	0.177	0.0236	0.0295
L1 ⁽¹⁾⁽¹¹⁾	1.00			-	0.0394	-
N ⁽¹³⁾	100					
θ	0°	3.5°	7°	0°	3.5°	7°
θ1	0°	-	-	0°	-	-
θ2	10°	12°	14°	10°	12°	14°
θ3	10°	12°	14°	10°	12°	14°
R1	0.08	-	-	0.0031	-	-
R2	0.08	-	0.20	0.0031	-	0.0079
S	0.20	-	-	0.0079	-	-
aaa ⁽¹⁾	0.20			0.0079		
bbb ⁽¹⁾	0.20			0.0079		
ccc ⁽¹⁾	0.08			0.0031		
ddd ⁽¹⁾	0.08			0.0031		

Notes:

1. Dimensioning and tolerancing schemes conform to ASME Y14.5M-1994.
2. The top package body size may be smaller than the bottom package size by as much as 0.15 mm.
3. Datums A-B and D to be determined at datum plane H.
4. To be determined at seating datum plane C.
5. Dimensions D1 and E1 do not include mold flash or protrusions. Allowable mold flash or protrusions is 0.25 mm per side. D1 and E1 are Maximum plastic body size dimensions including mold mismatch.
6. Details of pin 1 identifier are optional but must be located within the zone indicated.
7. All dimensions are in millimeters.
8. No intrusion allowed inwards the leads.
9. Dimension “b” does not include dambar protrusion. Allowable dambar protrusion shall not cause the lead width to exceed the maximum “b” dimension by more than 0.08 mm. Dambar cannot be located on the lower radius or the foot. Minimum space between protrusion and an adjacent lead is 0.07 mm for 0.4 mm and 0.5 mm pitch packages.
10. Exact shape of each corner is optional.
11. These dimensions apply to the flat section of the lead between 0.10 mm and 0.25 mm from the lead tip.
12. A1 is defined as the distance from the seating plane to the lowest point on the package body.
13. “N” is the number of terminal positions for the specified body size.
14. Values in inches are converted from mm and rounded to four decimal digits.
15. Drawing is not to scale.

Figure 75. LQFP100 - Footprint example

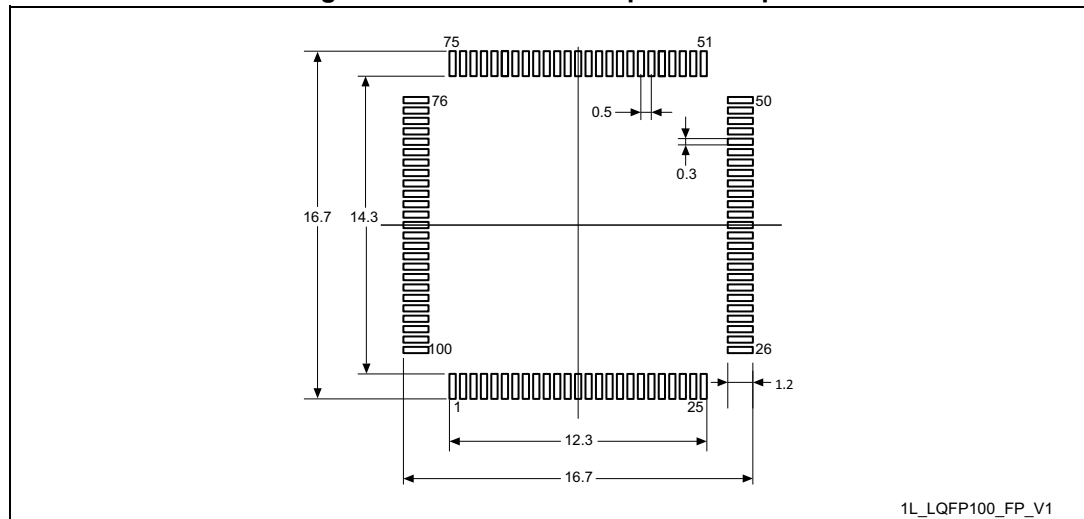

1. Dimensions are expressed in millimeters.

Prerelease product(s)

6.7 LQFP100 package information (OS)

This LQFP is a 100-pin, 14 x 14 mm, low-profile quad flat package.

Figure 76. LQFP100 - Outline

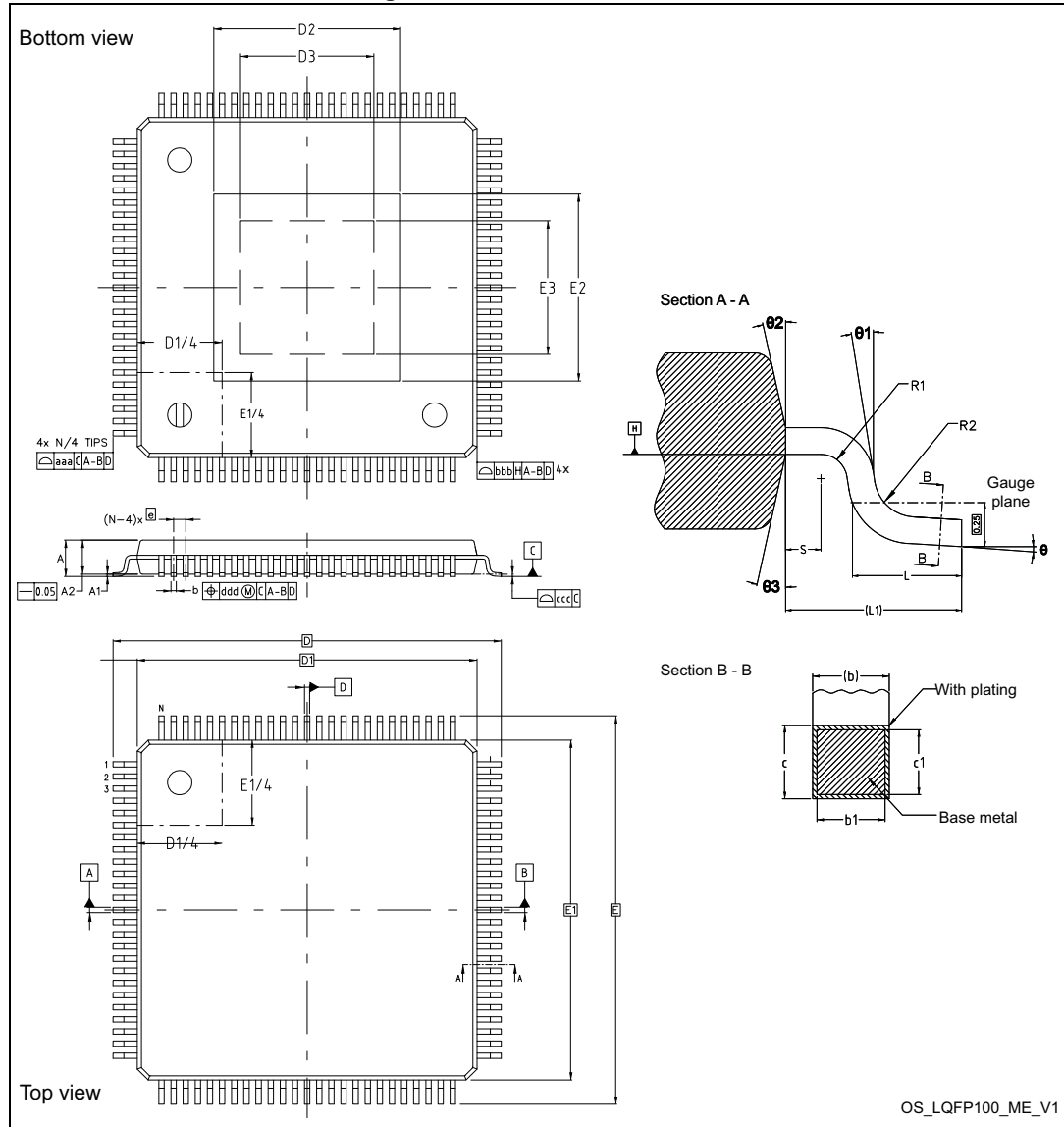

1. Drawing is not to scale.

Prerelease product(s)

Table 130. LQFP100 - Mechanical data

Symbol	Millimeters			Inches ⁽¹⁾		
	Min	Typ	Max	Min	Typ	Max
A ⁽²⁾	-	-	1.60	-	-	0.0630
A1 ⁽³⁾	0.05	-	0.15	0.0020	-	0.0059
A2	1.35	1.40	1.45	0.0531	0.0551	0.0571
b ⁽⁴⁾⁽⁵⁾	0.17	0.22	0.27	0.0067	0.0087	0.0106
b1 ⁽⁵⁾	0.17	0.20	0.23	0.0067	0.0079	0.0091
c ⁽⁵⁾	0.09	-	0.20	0.0035	-	0.0079
c1 ⁽⁵⁾	0.09	-	0.16	0.0035	-	0.0063
D ⁽⁶⁾⁽⁷⁾	16.00 BSC			0.6299 BSC		
D1 ⁽⁷⁾⁽⁸⁾⁽⁹⁾	14.00 BSC			0.5512 BSC		
D2 ⁽¹⁰⁾	-	-	5.55	-	-	0.2185
D3 ⁽¹¹⁾	4.65	-	-	0.1831	-	-
e ⁽⁷⁾	0.50 BSC			0.0197 BSC		
E ⁽⁶⁾⁽⁷⁾	16.00 BSC			0.6299 BSC		
E1 ⁽⁷⁾⁽⁸⁾⁽⁹⁾	14.00 BSC			0.5512 BSC		
E2 ⁽¹⁰⁾	-	-	5.55	-	-	0.2185
E3 ⁽¹¹⁾	4.65	-	-	0.1831	-	-
L	0.45	0.60	0.75	0.0177	0.0236	0.0295
L1	1.00 REF			0.0394 REF		
N ⁽¹²⁾	100					
θ	0°	3.5°	7°	0°	3.5°	7°
θ1	0°	-	-	0°	-	-
θ2	10°	12°	14°	10°	12°	14°
θ3	10°	12°	14°	10°	12°	14°
R1	0.08	-	-	0.0031	-	-
R2	0.08	-	0.20	0.0031	-	0.0079
S	0.20	-	-	0.0079	-	-
aaa ⁽¹³⁾	0.20			0.0079		
bbb ⁽¹³⁾	0.20			0.0079		
ccc ⁽¹³⁾	0.08			0.0031		
ddd ⁽¹³⁾	0.08			0.0031		

1. Values in inches are converted from millimeters and rounded to four decimal digits.
2. The profile height, A, is the distance from the seating plane to the highest point on the package. It is measured perpendicular to the seating plane.
3. A1 is defined as the distance from the seating plane to the lowest point on the package body.

4. Dimension b does not include dambar protrusion. Allowable dambar protrusion shall not cause the lead width to exceed the maximum b dimension by more than 0.08 mm. Dambar cannot be located on the lower radius or the foot. Minimum space between protrusion and an adjacent lead is 0.07 mm for 0.4 mm and 0.5 mm pitch packages.
5. These dimensions apply to the flat section of the lead between 0.10 mm and 0.25 mm from the lead tip.
6. To be determined at seating datum plane C.
7. BSC stands for basic dimensions. It corresponds to the nominal value and has no tolerance.
8. Top package body size may be smaller than the bottom package size by as much as 0.15 mm.
9. Dimensions D1 and E1 do not include mold flash or protrusions. Allowable mold flash or protrusions is 0.25 mm per side. D1 and E1 are maximum plastic body size dimensions including mold mismatch.
10. Dimensions D2 and E2 show the maximum exposed metal area on the package surface where the exposed pad is located. It includes all metal protrusions from exposed pad itself.
11. Dimensions D3 and E3 show the minimum solderable area, defined as the portion of exposed pad which is guaranteed to be free from resin flashes/bleeds, bordered by internal edge of inner groove.
12. N represents the total number of pins on the QFP.
13. Tolerance of form and position.

Figure 77. LQFP100 - Footprint example

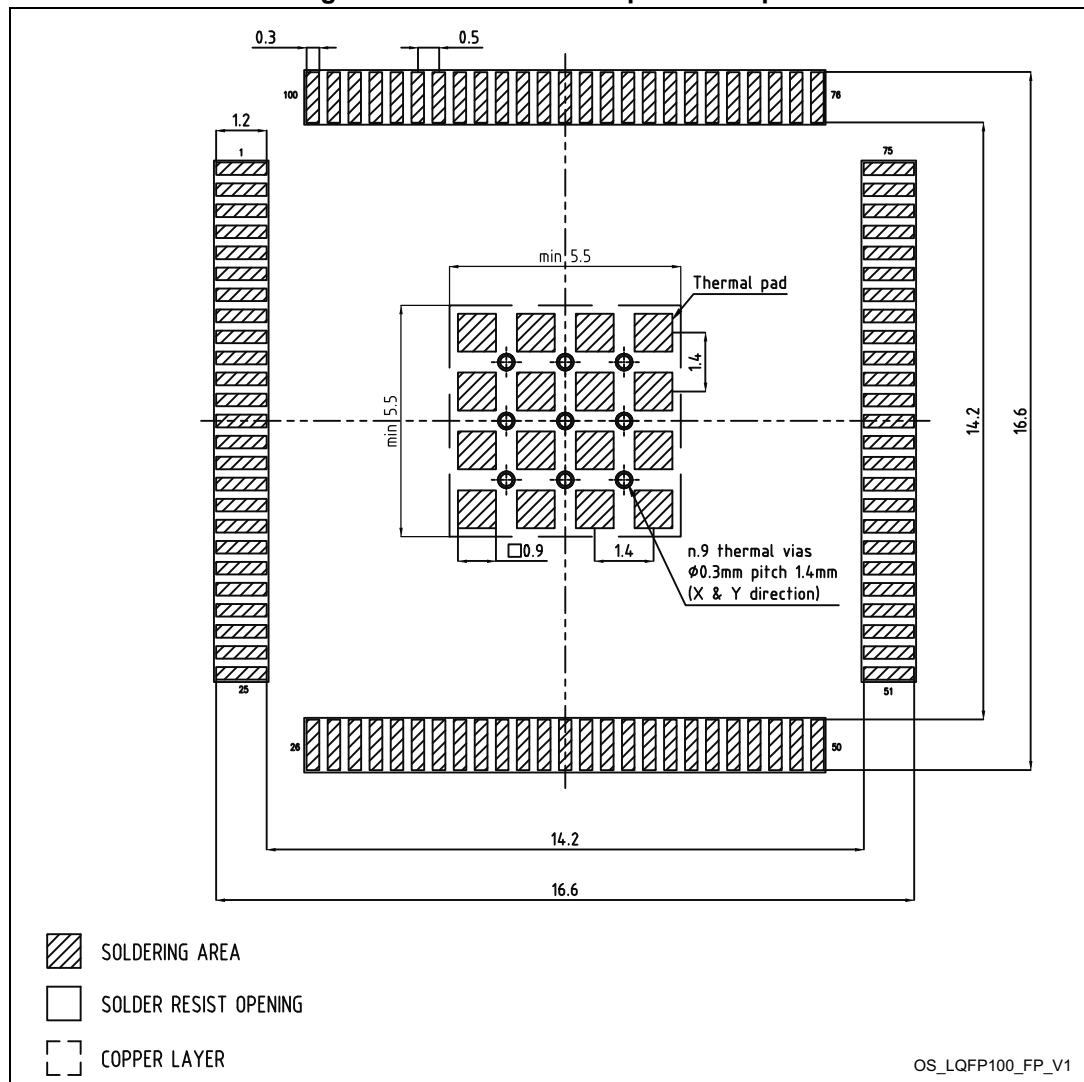

Prerelease product(s)

6.8 UFBGA100 package information (A0C2)

This UFBGA is a 100-ball, 7 x 7 mm, 0.50 mm pitch, ultra fine pitch ball grid array package.

Note: See list of notes in the notes section.

Figure 78. UFBGA100 - Outline⁽¹³⁾

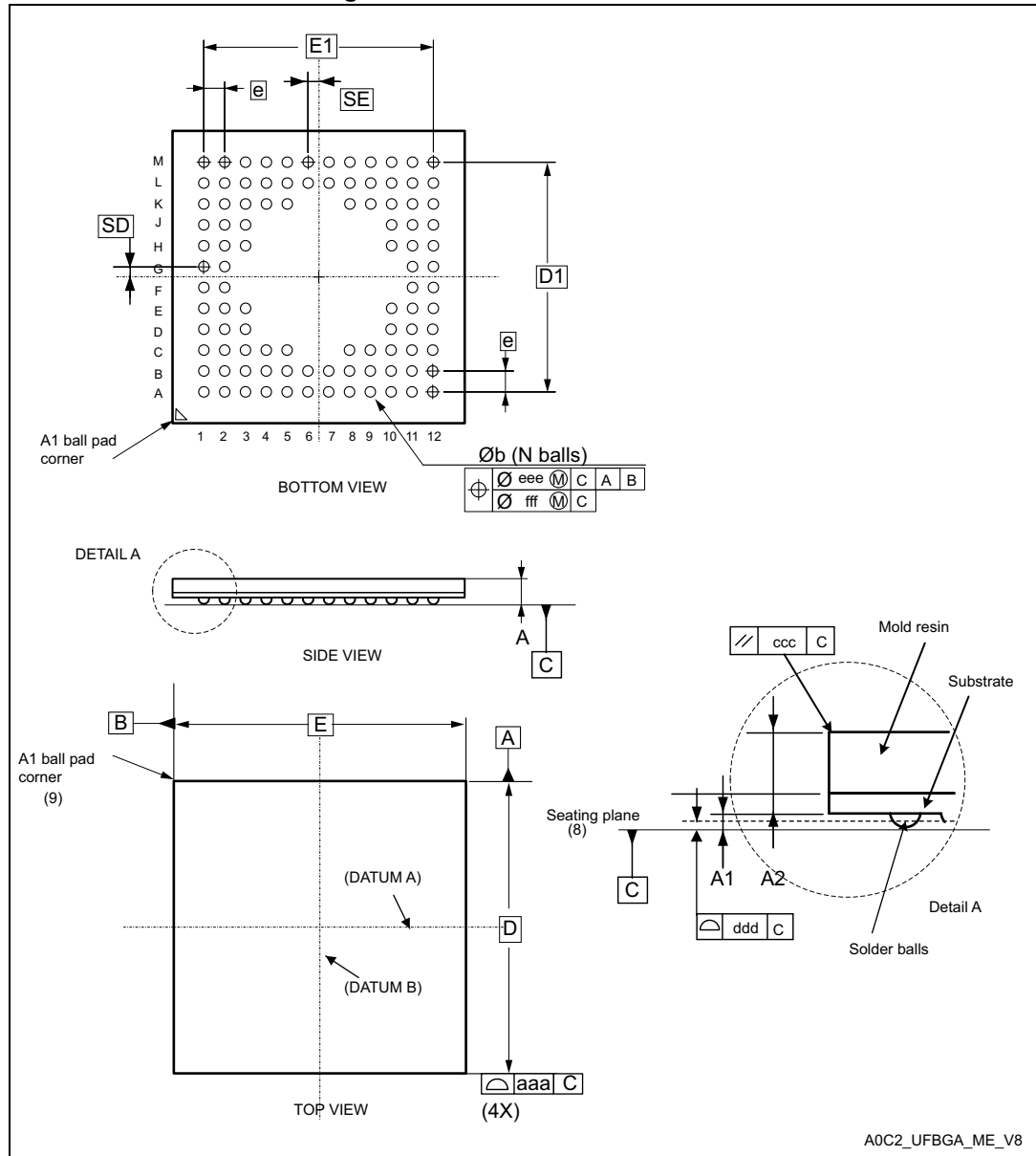

Prerelease product(s)

Table 131. UFBGA100 - Mechanical data

Symbol	millimeters ⁽¹⁾			inches ⁽¹²⁾		
	Min.	Typ.	Max.	Min.	Typ.	Max.
A ⁽²⁾⁽³⁾	-	-	0.60	-	-	0.0236
A1 ⁽⁴⁾	0.05	-	-	0.0020	-	-
A2	-	0.43	-	-	0.0169	-
b ⁽⁵⁾	0.23	0.28	0.33	0.0090	0.0110	0.0130
D ⁽⁶⁾	7.00 BSC			0.2756 BSC		
D1	5.50 BSC			0.2165 BSC		
E	7.00 BSC			0.2756 BSC		
E1	5.50 BSC			0.2165 BSC		
e ⁽⁹⁾	0.50 BSC			0.0197 BSC		
N ⁽¹¹⁾	100					
SD ⁽¹²⁾	0.25 BSC			0.0098 BSC		
SE ⁽¹²⁾	0.25 BSC			0.0098 BSC		
aaa	0.15			0.0059		
ccc	0.20			0.0079		
ddd	0.08			0.0031		
eee	0.15			0.0059		
fff	0.05			0.0020		

Notes:

1. Dimensioning and tolerancing schemes conform to ASME Y14.5M-2009 apart European projection.
2. UFBGA stands for ultra profile fine pitch ball grid array: 0.50 mm < A ≤ 0.65 mm / fine pitch e < 1.00 mm.
3. The profile height, A, is the distance from the seating plane to the highest point on the package. It is measured perpendicular to the seating plane.
4. A1 is defined as the distance from the seating plane to the lowest point on the package body.
5. Dimension b is measured at the maximum diameter of the terminal (ball) in a plane parallel to primary datum C.
6. BSC stands for BASIC dimensions. It corresponds to the nominal value and has no tolerance. For tolerances refer to form and position table. On the drawing these dimensions are framed.
7. Primary datum C is defined by the plane established by the contact points of three or more solder balls that support the device when it is placed on top of a planar surface.

8. The terminal (ball) A1 corner must be identified on the top surface of the package by using a corner chamfer, ink or metalized markings, or other feature of package body or integral heat slug. A distinguish feature is allowable on the bottom surface of the package to identify the terminal A1 corner. Exact shape of each corner is optional.
9. e represents the solder ball grid pitch.
10. N represents the total number of balls on the BGA.
11. Basic dimensions SD and SE are defined with respect to datums A and B. It defines the position of the centre ball(s) in the outer row or column of a fully populated matrix.
12. Values in inches are converted from mm and rounded to four decimal digits.
13. Drawing is not to scale.

Figure 79. UFBGA100 - Footprint example

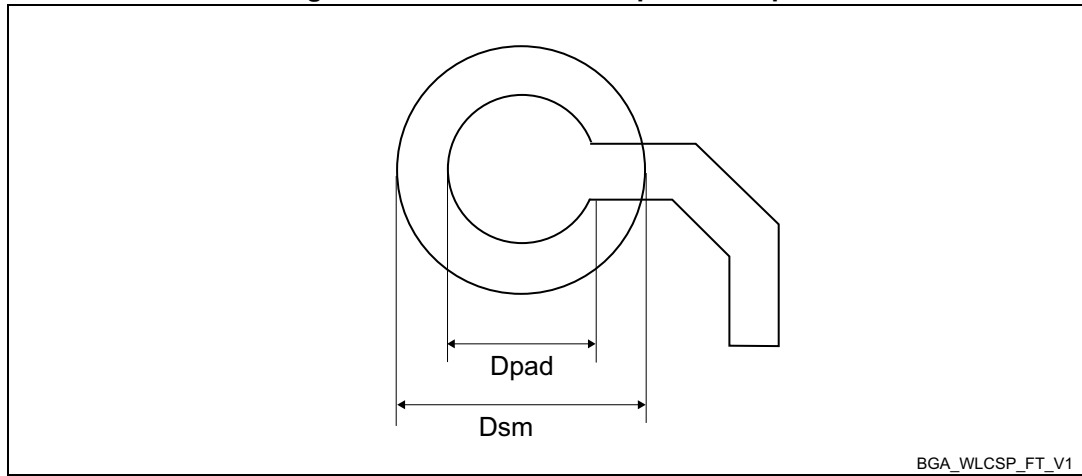

Table 132. UFBGA100 - Example of PCB design rules (0.5 mm pitch BGA)

Dimension	Values
Pitch	0.50 mm
Dpad	0.280 mm
Dsm	0.370 mm typ. (depends on the solder mask registration tolerance)
Stencil opening	0.280 mm
Stencil thickness	Between 0.100 mm and 0.125 mm

Prerelease product(s)

6.9 LQFP144 package information (1A)

This LQFP is a 144-pin, 20 x 20 mm low-profile quad flat package.

Note: See list of notes in the notes section.

Figure 80. LQFP144 - Outline⁽¹⁵⁾

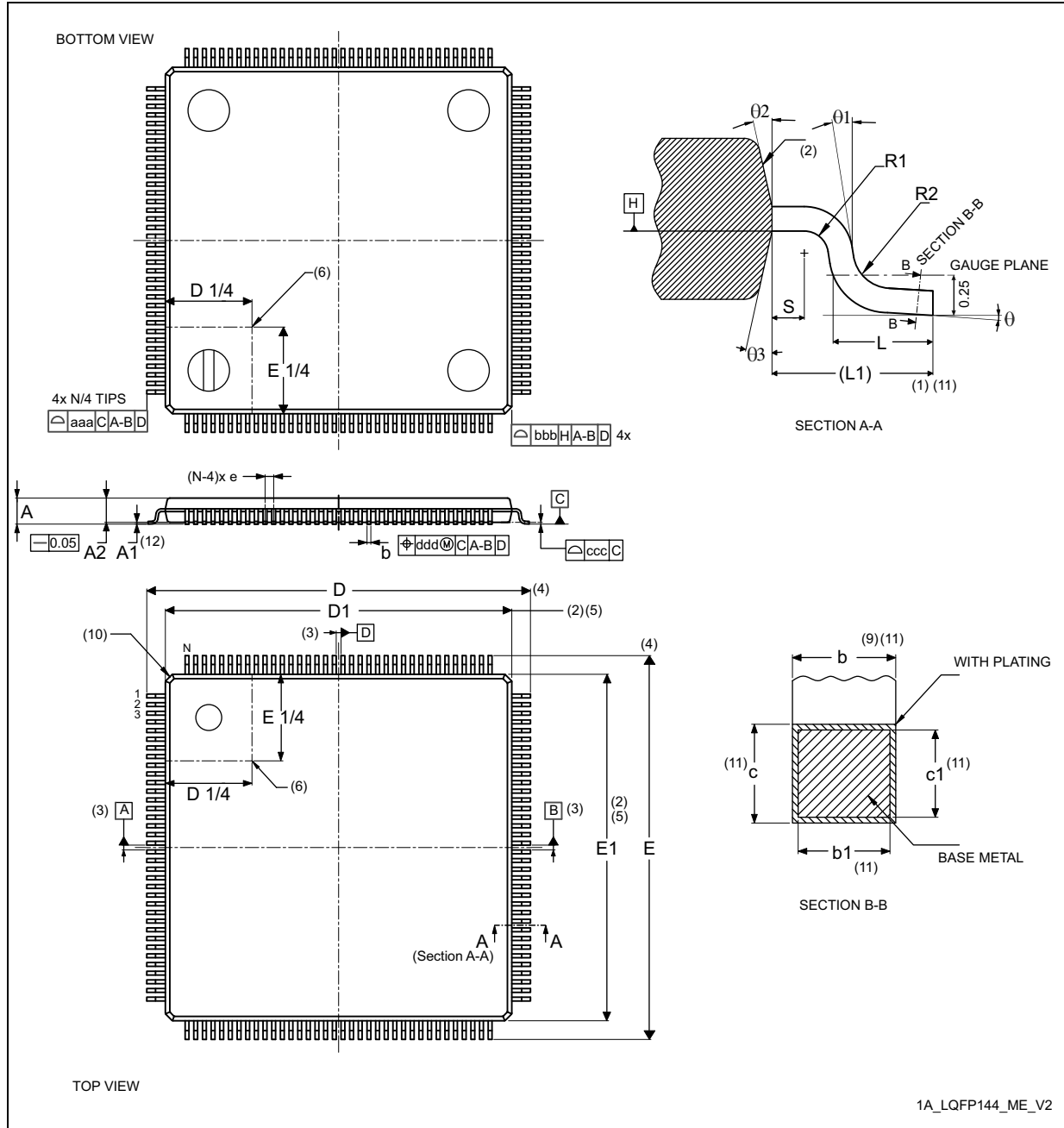

Prerelease product(s)

Table 133. LQFP144 - Mechanical data

Symbol	Millimeters			Inches ⁽¹⁴⁾		
	Min	Typ	Max	Min	Typ	Max
A	-	-	1.60	-	-	0.0630
A1 ⁽¹²⁾	0.05	-	0.15	0.0020	-	0.0059
A2	1.35	1.40	1.45	0.0531	0.0551	0.0571
b ⁽⁹⁾⁽¹¹⁾	0.17	0.22	0.27	0.0067	0.0087	0.0106
b1 ⁽¹¹⁾	0.17	0.20	0.23	0.0067	0.0079	0.0090
c ⁽¹¹⁾	0.09	-	0.20	0.0035	-	0.0079
c1 ⁽¹¹⁾	0.09	-	0.16	0.0035	-	0.0063
D ⁽⁴⁾	22.00 BSC			0.8661 BSC		
D1 ⁽²⁾⁽⁵⁾	20.00 BSC			0.7874 BSC		
E ⁽⁴⁾	22.00 BSC			0.8661 BSC		
E1 ⁽²⁾⁽⁵⁾	20.00 BSC			0.7874 BSC		
e	0.50 BSC			0.0197 BSC		
L	0.45	0.60	0.75	0.0177	0.0236	0.0295
L1	1.00 REF			0.0394 REF		
N ⁽¹³⁾	144					
θ	0°	3.5°	7°	0°	3.5°	7°
θ1	0°	-	-	0°	-	-
θ2	10°	12°	14°	10°	12°	14°
θ3	10°	12°	14°	10°	12°	14°
R1	0.08	-	-	0.0031	-	-
R2	0.08	-	0.20	0.0031	-	0.0079
S	0.20	-	-	0.0079	-	-
aaa	0.20			0.0079		
bbb	0.20			0.0079		
ccc	0.08			0.0031		
ddd	0.08			0.0031		

Notes:

1. Dimensioning and tolerancing schemes conform to ASME Y14.5M-1994.
2. The top package body size may be smaller than the bottom package size by as much as 0.15 mm.
3. Datums A-B and D to be determined at datum plane H.
4. To be determined at seating datum plane C.

6.10 LQFP144 package information (ZO)

This LQFP is a 144-pin, 20 x 20 mm, low-profile quad flat package.

Figure 82. LQFP144 - Outline

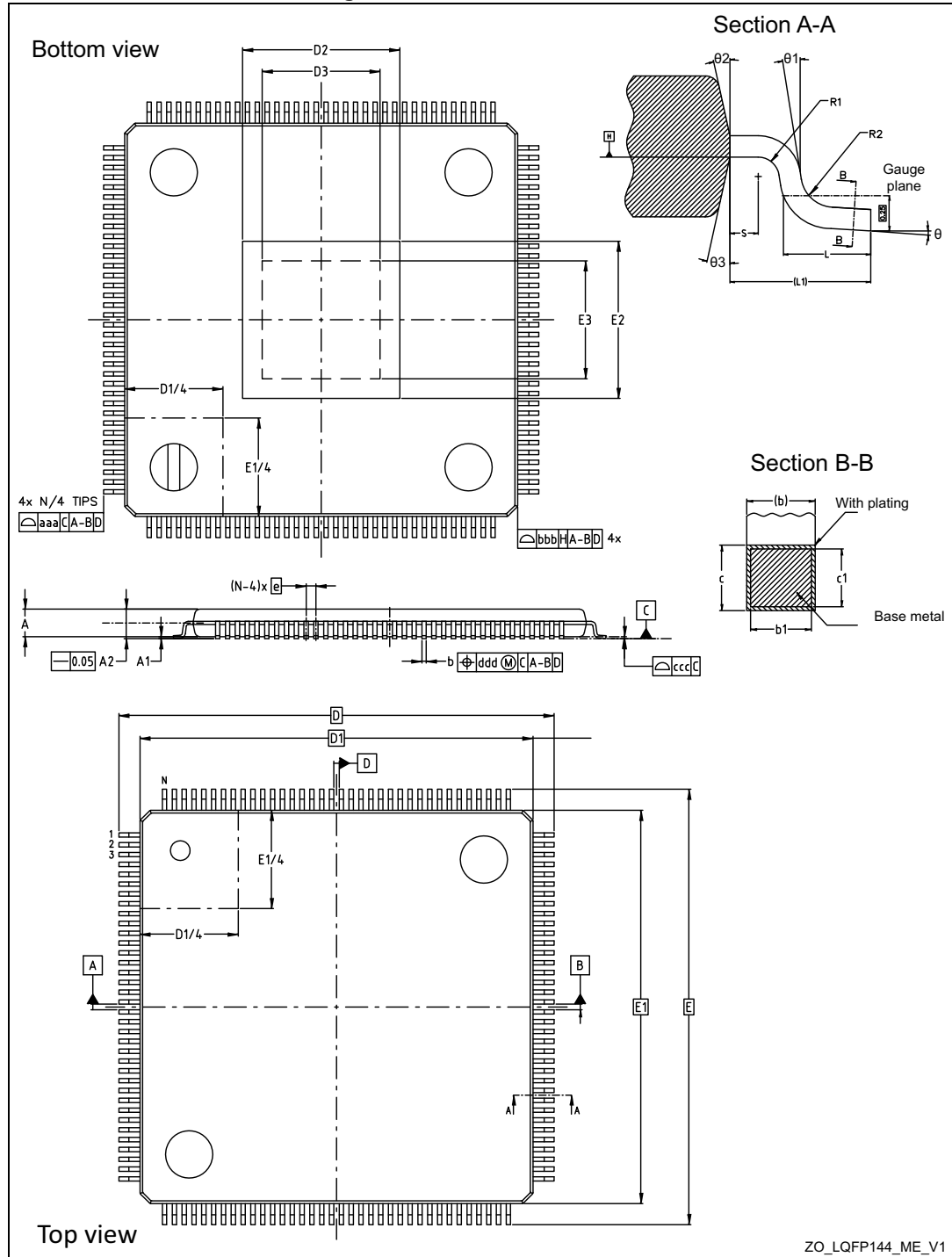

1. Drawing is not to scale.

Prerelease product(s)

Table 134. LQFP144 - Mechanical data

Symbol	Millimeters			Inches ⁽¹⁾		
	Min	Typ	Max	Min	Typ	Max
A ⁽²⁾	-	-	1.60	-	-	0.0630
A1 ⁽³⁾	0.05	-	0.15	0.0020	-	0.0059
A2	1.35	1.40	1.45	0.0531	0.0551	0.0571
b ⁽⁴⁾⁽⁵⁾	0.17	0.22	0.27	0.0067	0.0087	0.0106
b1 ⁽⁵⁾	0.17	0.20	0.23	0.0067	0.0079	0.0090
c ⁽⁵⁾	0.09	-	0.20	0.0035	-	0.0079
c1 ⁽⁵⁾	0.09	-	0.16	0.0035	-	0.0063
D ⁽⁶⁾⁽⁷⁾	22.00 BSC			0.8661 BSC		
D1 ⁽⁷⁾⁽⁸⁾⁽⁹⁾	20.00 BSC			0.7874 BSC		
D2 ⁽¹⁰⁾	-	-	8.25	-	-	0.3248
D3 ⁽¹¹⁾	7.25	-	-	0.2854	-	-
e ⁽⁷⁾	0.50 BSC			0.0197 BSC		
E ⁽⁶⁾⁽⁷⁾	22.00 BSC			0.8661 BSC		
E1 ⁽⁷⁾⁽⁸⁾⁽⁹⁾	20.00 BSC			0.7874 BSC		
E2 ⁽¹⁰⁾	-	-	8.25	-	-	0.3248
E3 ⁽¹¹⁾	7.25	-	-	0.2854	-	-
L	0.45	0.60	0.75	0.0177	0.0236	0.0295
L1	1.00 REF			0.0394 REF		
R1	0.08	-	-	0.0031	-	-
R2	0.08	-	0.20	0.0031	-	0.0079
S	0.20	-	-	0.0079	-	-
θ	0°	3.5°	7°	0°	3.5°	7°
θ1	0°	-	-	0°	-	-
θ2	10°	12°	14°	10°	12°	14°
θ3	10°	12°	14°	10°	12°	14°
aaa ⁽¹²⁾	0.20			0.0079		
bbb ⁽¹³⁾	0.20			0.0079		
ccc ⁽¹³⁾	0.08			0.0031		
ddd ⁽¹³⁾	0.08			0.0031		

1. Values in inches are converted from millimeters and rounded to four decimal digits.
2. The profile height, A, is the distance from the seating plane to the highest point on the package. It is measured perpendicular to the seating plane.
3. A1 is defined as the distance from the seating plane to the lowest point on the package body.

Prerelease product(s)

4. Dimension b does not include dambar protrusion. Allowable dambar protrusion shall not cause the lead width to exceed the maximum b dimension by more than 0.08 mm. Dambar cannot be located on the lower radius or the foot. Minimum space between protrusion and an adjacent lead is 0.07 mm for 0.4 mm and 0.5 mm pitch packages.
5. These dimensions apply to the flat section of the lead between 0.10 mm and 0.25 mm from the lead tip.
6. To be determined at seating datum plane C.
7. BSC stands for basic dimensions. It corresponds to the nominal value and has no tolerance.
8. Top package body size may be smaller than the bottom package size by as much as 0.15 mm.
9. Dimensions D1 and E1 do not include mold flash or protrusions. Allowable mold flash or protrusions is 0.25 mm per side. D1 and E1 are maximum plastic body size dimensions including mold mismatch.
10. Dimensions D2 and E2 show the maximum exposed metal area on the package surface where the exposed pad is located. It includes all metal protrusions from exposed pad itself.
11. Dimensions D3 and E3 show the minimum solderable area, defined as the portion of exposed pad which is guaranteed to be free from resin flashes/bleeds, bordered by internal edge of inner groove.
12. Tolerance of form and position.

Figure 83. LQFP144 - Footprint example

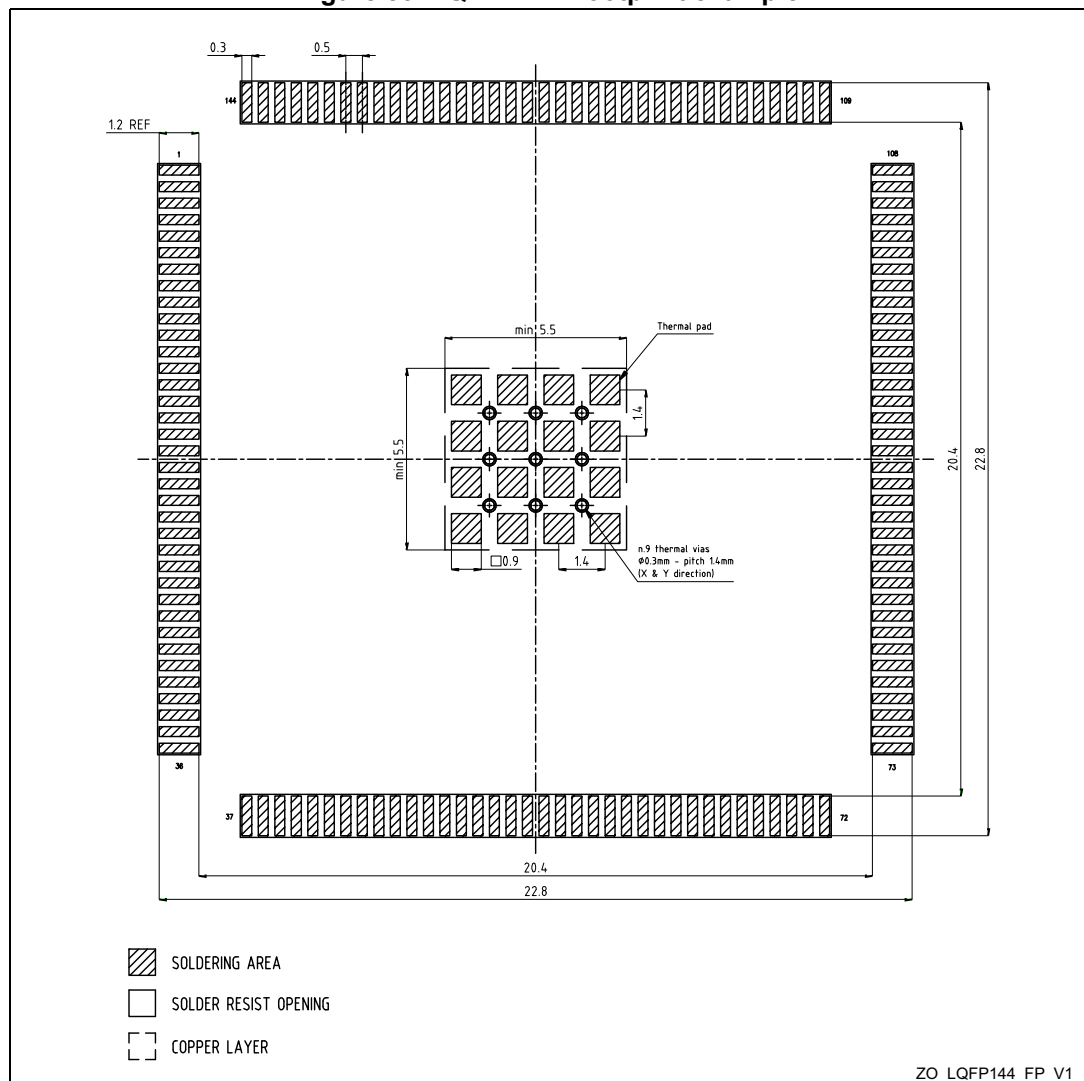

Prerelease product(s)

6.11 UFBGA144 package information (A0Y2)

This UFBGA is a 144-pin, 10 x 10 mm, 0.80 mm pitch, ultra fine pitch ball grid array package.

Note: See list of notes in the notes section.

Figure 84. UFBGA144 - Outline⁽¹³⁾

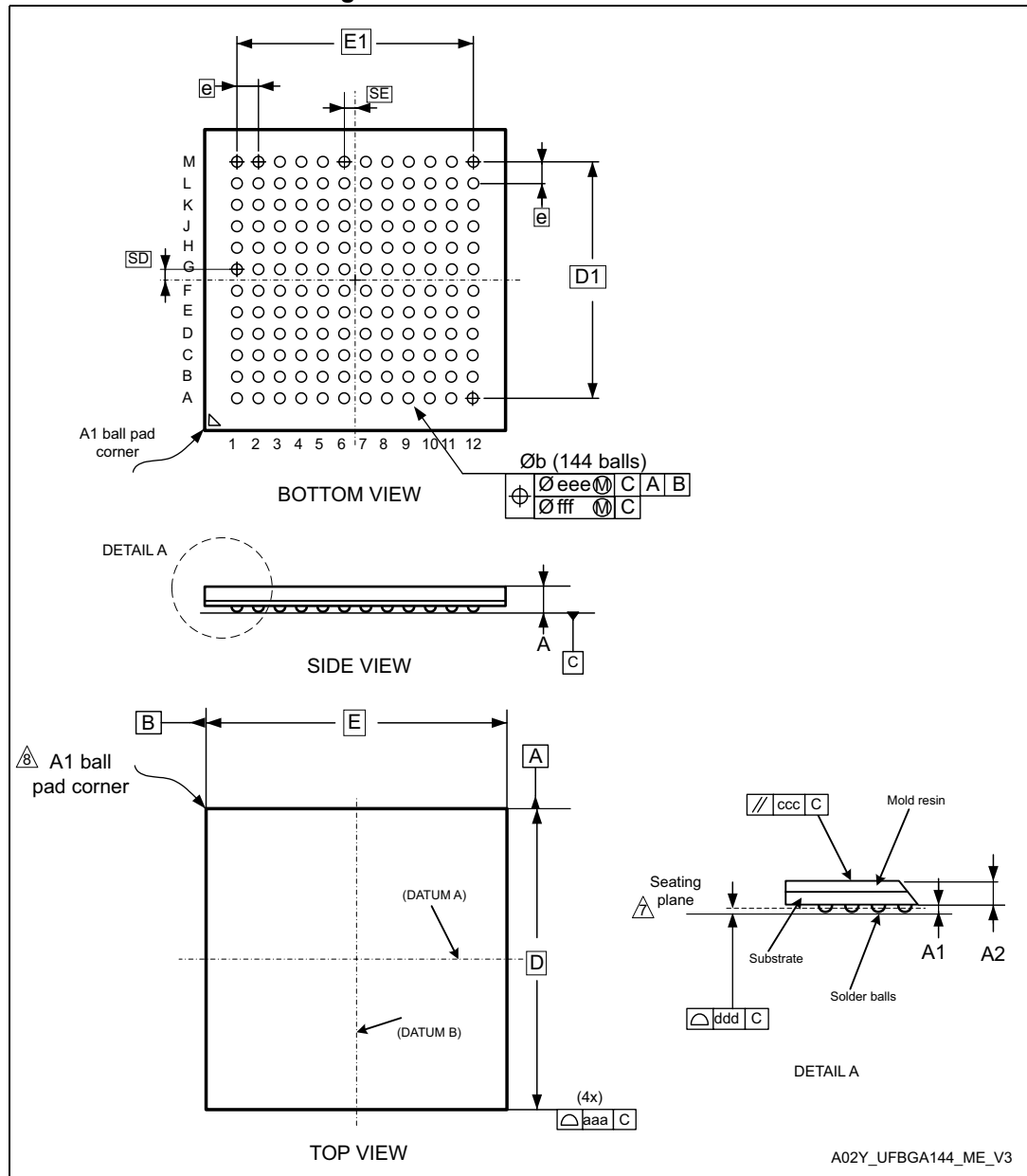

Prerelease product(s)

Table 135. UFBGA144 - Mechanical data

Symbol	Millimeters ⁽¹⁾			Inches ⁽¹²⁾		
	Min.	Typ.	Max.	Min.	Typ.	Max.
A ⁽²⁾⁽³⁾	-	-	0.60	-	-	0.0236
A1 ⁽⁴⁾	0.05	-	-	0.0020	-	-
A2	-	0.43	-	-	0.0169	-
b ⁽⁵⁾	0.35	0.40	0.45	0.0138	0.0157	0.0177
D	10.00 BSC ⁽⁶⁾			0.3937 BSC		
D1	8.80 BSC			0.3465 BSC		
E	10.00 BSC			0.3937 BSC		
E1	8.80 BSC			0.3465 BSC		
e ⁽⁹⁾	0.80 BSC			0.0315 BSC		
N ⁽¹¹⁾	144					
SD ⁽¹²⁾	0.40 BSC			0.0157 BSC		
SE ⁽¹²⁾	0.40 BSC			0.0157 BSC		
aaa	0.15			0.0059		
ccc	0.20			0.0079		
ddd	0.10			0.0039		
eee	0.15			0.0059		
fff	0.08			0.0031		

Notes:

1. Dimensioning and tolerancing schemes conform to ASME Y14.5M-2009 apart European projection.
2. UFBGA stands for ultra profile fine pitch ball grid array: $0.50 \text{ mm} < A \leq 0.65 \text{ mm}$ / fine pitch $e < 1.00 \text{ mm}$.
3. The profile height, A, is the distance from the seating plane to the highest point on the package. It is measured perpendicular to the seating plane.
4. A1 is defined as the distance from the seating plane to the lowest point on the package body.
5. Dimension b is measured at the maximum diameter of the terminal (ball) in a plane parallel to primary datum C.
6. BSC stands for BASIC dimensions. It corresponds to the nominal value and has no tolerance. For tolerances refer to form and position table. On the drawing these dimensions are framed.
7. Primary datum C is defined by the plane established by the contact points of three or more solder balls that support the device when it is placed on top of a planar surface.

8. The terminal (ball) A1 corner must be identified on the top surface of the package by using a corner chamfer, ink or metalized markings, or other feature of package body or integral heat slug. A distinguish feature is allowable on the bottom surface of the package to identify the terminal A1 corner. Exact shape of each corner is optional.
9. e represents the solder ball grid pitch.
10. N represents the total number of balls on the BGA.
11. Basic dimensions SD and SE are defined with respect to datums A and B. It defines the position of the center ball(s) in the outer row or column of a fully populated matrix.
12. Values in inches are converted from mm and rounded to four decimal digits.
13. Drawing is not to scale.

Figure 85. UFBGA144 - Footprint example

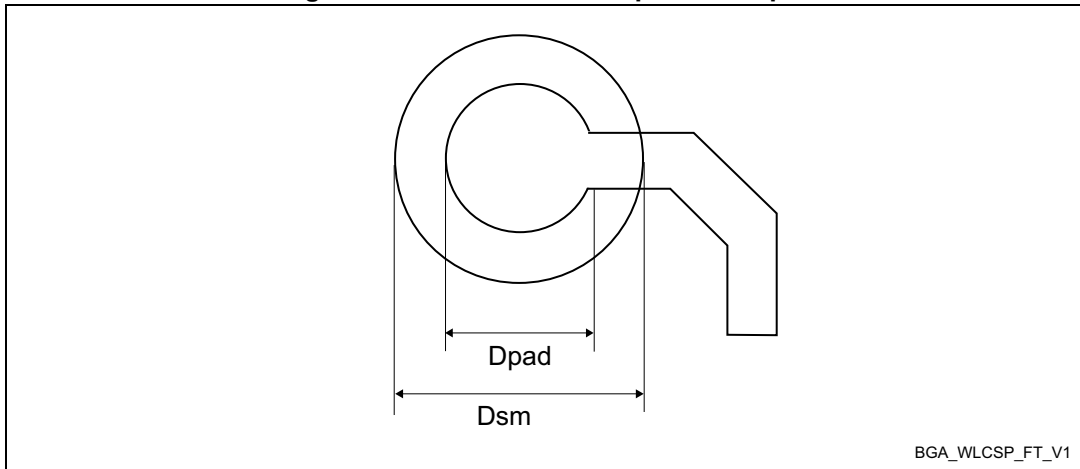

Table 136. UFBGA144 - Example of PCB design rules (0.80 mm pitch BGA)

Dimension	Values
Pitch	0.80 mm
D_{pad}	0.400 mm
D_{sm}	0.550 mm typical (depends on the soldermask registration tolerance)
Stencil opening	0.400 mm
Stencil thickness	Between 0.100 mm and 0.125 mm
Pad trace width	0.120 mm

Prerelease product(s)

6.12 Package thermal characteristics

The maximum chip-junction temperature, T_{Jmax} in degrees Celsius, can be calculated using the following equation:

$$T_{Jmax} = T_{Amax} + (P_{Dmax} \times \Theta_{JA})$$

Where:

- T_{Amax} is the maximum ambient temperature in °C,
- Θ_{JA} is the package junction-to-ambient thermal resistance, in °C/W,
- P_{Dmax} is the sum of P_{INTmax} and $P_{I/Omax}$ ($P_{Dmax} = P_{INTmax} + P_{I/Omax}$),
- P_{INTmax} is the product of I_{DD} and V_{DD} , expressed in Watts. This is the maximum chip internal power.

$P_{I/Omax}$ represents the maximum power dissipation on output pins:

$$P_{I/Omax} = \sum (V_{OL} \times I_{OL}) + \sum ((V_{DD} - V_{OH}) \times I_{OH}),$$

taking into account the actual V_{OL} / I_{OL} and V_{OH} / I_{OH} of the I/Os at low and high level in the application.

Table 137. Package thermal characteristics

Symbol	Definition	Parameter	Value	Unit
θ_{JA}	Thermal resistance junction-ambient	UFQFPN48 (7 x 7 mm)	27.7	°C/W
		LQFP48 (7 x 7 mm)	48.4	
		WLCSP63 (3.01 x 2.97 mm)	56.7	
		LQFP64 (10 x 10 mm)	40.0	
		LQFP100 (14 x 14 mm)	35.9	
		LQFP100-EP (14 x 14 mm)	24.2	
		UFBGA100 (7 x 7 mm)	53.7	
		LQFP144 (20 x 20 mm)	37.3	
		LQFP144-EP (20 x 20 mm)	21.7	
		UFBGA144 (10 x 10 mm)	44.8	
θ_{JB}	Thermal resistance junction-board	UFQFPN48 (7 x 7 mm)	11.8	°C/W
		LQFP48 (7 x 7 mm)	25.5	
		WLCSP63 (3.01 x 2.97 mm)	32.0	
		LQFP64 (10 x 10 mm)	22.4	
		LQFP100 (14 x 14 mm)	21.8	
		LQFP100-EP (14 x 14 mm)	12.2	
		UFBGA100 (7 x 7 mm)	38.8	
		LQFP144 (20 x 20 mm)	26.2	
		LQFP144-EP (20 x 20 mm)	11.8	
		UFBGA144 (10 x 10 mm)	32.7	

Prerelease product(s)

Table 137. Package thermal characteristics (continued)

Symbol	Definition	Parameter	Value	Unit
θ_{JC}	Thermal resistance junction-case	UFQFPN48 (7 x 7 mm)	7.8	°C/W
		LQFP48 (7 x 7 mm)	13.7	
		WLCSP63 (3.01 x 2.97 mm)	3.6	
		LQFP64 (10 x 10 mm)	10.2	
		LQFP100 (14 x 14 mm)	8.9	
		LQFP100-EP (14 x 14 mm)	16.6	
		UFBGA100 (7 x 7 mm)	13.6	
		LQFP144 (20 x 20 mm)	9.1	
		LQFP144-EP (20 x 20 mm)	13.1	
		UFBGA144 (10 x 10 mm)	15.4	

6.12.1 Reference documents

- JESD51-2 Integrated Circuits Thermal Test Method Environment Conditions - Natural Convection (Still Air). Available from www.jedec.org.
- For information on thermal management, refer to “*Thermal management guidelines for STM32 32-bit Arm Cortex MCUs applications*” (AN5036) available from www.st.com.

Prerelease product(s)

7 Ordering information

Example: STM32 H 543 V E T 6 TR

Device family

STM32 = Arm based 32-bit microcontroller

Product type

H = High performance

Device subfamily

543 = STM32H543xx devices

Pin count

- C = 48 pins
- U = 63 balls
- R = 64 pins
- V = 100 pins/balls
- Z = 144 pins/balls

Flash memory size

- G = 1 Mbyte
- E = 512 Kbytes

Package

- U = UFQFPN
- T = LQFP
- I = UFBGA (7 x 7 mm)
- J = UFBGA (10 x 10)
- Z = LQFP-EP (exposed pad)
- Y = WLCSP

Temperature range

- 6 = -40 to 85°C
- 7 = -40 to 105°C
- 3 = -40 to 125°C (only with exposed pad package)

Packing

- TR = Tape and reel
- xxx = Programmed parts

For a list of available options (such as speed or package) or for further information on any aspect of this device, contact the nearest ST sales office.

Prerelease product(s)

8 Important security notice

The STMicroelectronics group of companies (ST) places a high value on product security, which is why the ST product(s) identified in this documentation may be certified by various security certification bodies and/or may implement our own security measures as set forth herein. However, no level of security certification and/or built-in security measures can guarantee that ST products are resistant to all forms of attacks. As such, it is the responsibility of each of ST's customers to determine if the level of security provided in an ST product meets the customer needs both in relation to the ST product alone, as well as when combined with other components and/or software for the customer end product or application. In particular, take note that:

- ST products may have been certified by one or more security certification bodies, such as Platform Security Architecture (www.psacertified.org) and/or Security Evaluation standard for IoT Platforms (www.trustcb.com). For details concerning whether the ST product(s) referenced herein have received security certification along with the level and current status of such certification, either visit the relevant certification standards website or go to the relevant product page on www.st.com for the most up to date information. As the status and/or level of security certification for an ST product can change from time to time, customers should re-check security certification status/level as needed. If an ST product is not shown to be certified under a particular security standard, customers should not assume it is certified.
- Certification bodies have the right to evaluate, grant and revoke security certification in relation to ST products. These certification bodies are therefore independently responsible for granting or revoking security certification for an ST product, and ST does not take any responsibility for mistakes, evaluations, assessments, testing, or other activity carried out by the certification body with respect to any ST product.
- Industry-based cryptographic algorithms (such as AES, DES, or MD5) and other open standard technologies which may be used in conjunction with an ST product are based on standards which were not developed by ST. ST does not take responsibility for any flaws in such cryptographic algorithms or open technologies or for any methods which have been or may be developed to bypass, decrypt or crack such algorithms or technologies.
- While robust security testing may be done, no level of certification can absolutely guarantee protections against all attacks, including, for example, against advanced attacks which have not been tested for, against new or unidentified forms of attack, or against any form of attack when using an ST product outside of its specification or intended use, or in conjunction with other components or software which are used by customer to create their end product or application. ST is not responsible for resistance against such attacks. As such, regardless of the incorporated security features and/or any information or support that may be provided by ST, each customer is solely responsible for determining if the level of attacks tested for meets their needs, both in relation to the ST product alone and when incorporated into a customer end product or application.
- All security features of ST products (inclusive of any hardware, software, documentation, and the like), including but not limited to any enhanced security features added by ST, are provided on an "AS IS" BASIS. AS SUCH, TO THE EXTENT PERMITTED BY APPLICABLE LAW, ST DISCLAIMS ALL WARRANTIES, EXPRESS OR IMPLIED, INCLUDING BUT NOT LIMITED TO THE IMPLIED WARRANTIES OF MERCHANTABILITY OR FITNESS FOR A PARTICULAR PURPOSE, unless the applicable written and signed contract terms specifically provide otherwise.

9 Revision history

Table 138. Document revision history

Date	Revision	Changes
08-Jul-2026	1	Initial release.

IMPORTANT NOTICE – READ CAREFULLY

STMicroelectronics NV and its subsidiaries (“ST”) reserve the right to make changes, corrections, enhancements, modifications, and improvements to ST products and/or to this document at any time without notice.

In the event of any conflict between the provisions of this document and the provisions of any contractual arrangement in force between the purchasers and ST, the provisions of such contractual arrangement shall prevail.

The purchasers should obtain the latest relevant information on ST products before placing orders. ST products are sold pursuant to ST’s terms and conditions of sale in place at the time of order acknowledgment.

The purchasers are solely responsible for the choice, selection, and use of ST products and ST assumes no liability for application assistance or the design of the purchasers’ products.

No license, express or implied, to any intellectual property right is granted by ST herein.

Resale of ST products with provisions different from the information set forth herein shall void any warranty granted by ST for such product.

If the purchasers identify an ST product that meets their functional and performance requirements but that is not designated for the purchasers’ market segment, the purchasers shall contact ST for more information.

ST and the ST logo are trademarks of ST. For additional information about ST trademarks, refer to www.st.com/trademarks. All other product or service names are the property of their respective owners.

Information in this document supersedes and replaces information previously supplied in any prior versions of this document.

© 2026 STMicroelectronics – All rights reserved