

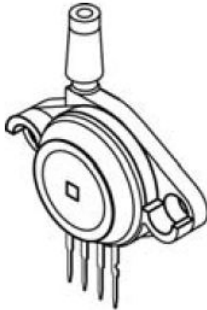

50 kPa on-chip temperature compensated and calibrated silicon pressure sensors



**MPX2050D
CASE 344-15**



**MPX2050GP
CASE 344B-01**

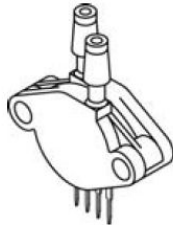

**MPX2050DP
CASE 344C-01**

Features

- Temperature Compensated Over 0°C to +85°C
- Unique Silicon Shear Stress Strain Gauge
- Easy to Use Chip Carrier Package Options
- Ratiometric to Supply Voltage
- Differential and Gauge Options
- $\pm 0.25\%$ Linearity

Application

- Pump/Motor Controllers
- Robotics
- Level Indicators
- Medical Diagnostics
- Pressure Switching
- Non-Invasive Blood Pressure

Description

The MPX2050 series devices are silicon piezoresistive pressure sensors providing a highly accurate and linear voltage output, directly proportional to the applied pressure. The sensor is a single, monolithic silicon diaphragm with the strain gauge and a thin-film resistor network integrated on-chip. The chip is laser trimmed for precise span and offset calibration and temperature compensation.

1 Ordering Information

Table 1. Ordering information

ORDERING INFORMATION									
Device Name	Package Options	Case No.	None	Single	Dual	Gauge	Differential	Absolute	Device Marking
			Ports			Pressure Type			
Unibody Package (MPX2050 Series)									
MPX2050D	Tray	344	•				•		MPX2050D
MPX2050GP	Tray	344B		•		•			MPX2050GP
MPX2050DP	Tray	344C			•		•		MPX2050DP

2 Voltage Output versus Applied Differential Pressure

Figure 1 shows a block diagram of the internal circuitry on the stand-alone pressure sensor chip.

Figure 1. Temperature Compensated Pressure Sensor Schematic

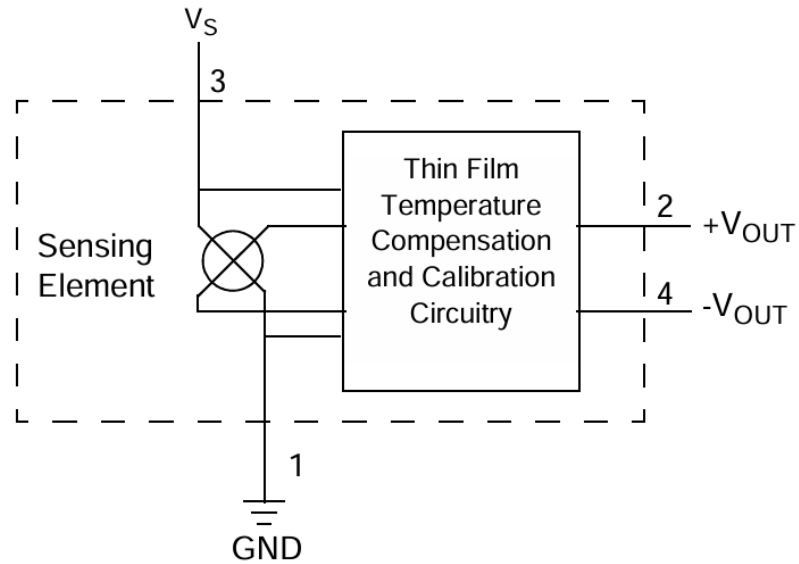

The differential voltage output of the sensor is directly proportional to the differential pressure applied. The output voltage of the differential or gauge sensor increases with increasing pressure applied to the pressure side (P1) relative to the vacuum side (P2). Similarly, output voltage increases as increasing vacuum is applied to the vacuum side (P2) relative to the pressure side (P1).

3 Operating Characteristics

Table 2. Operating Characteristics

($V_S = 10$ Vdc, $T_A = 25^\circ\text{C}$ unless otherwise noted, $P_1 > P_2$)

Characteristics	Symbol	Min	Typ	Max	Unit
Pressure Range ⁽¹⁾	P_{OP}	0	—	50	kPa
Supply Voltage ⁽²⁾	V_S	—	10	16	Vdc
Supply Current	I_o	—	6.0	—	mAdc
Full Scale Span ⁽³⁾	V_{FSS}	38.5	40	41.5	mV
Offset ⁽⁴⁾	V_{off}	-1.0	—	1.0	mV
Sensitivity	$\Delta V/\Delta P$	—	0.8	—	mV/kPa
Linearity ⁽⁵⁾	—	-0.25	—	0.25	% V_{FSS}
Pressure Hysteresis ⁽⁵⁾ (0 to 50 kPa)	—	—	± 0.1	—	% V_{FSS}
Temperature Hysteresis ⁽⁵⁾ (-40°C to $+125^\circ\text{C}$)	—	—	± 0.5	—	% V_{FSS}
Temperature Effect on Full Scale Span ⁽⁵⁾	TCV_{FSS}	-1.0	-	1.0	% V_{FSS}
Temperature Effect on Offset ⁽⁵⁾	TCV_{off}	-1.0	-	1.0	mV
Input Impedance	Z_{in}	1000	-	2500	Ω
Output Impedance	Z_{out}	1400	-	3000	Ω
Response Time ⁽⁶⁾ (10% to 90%)	t_R	—	1.0	—	ms
Warm-Up	—	—	20	—	ms
Offset Stability ⁽⁷⁾	—	—	± 0.5	—	% V_{FSS}

- 1.0 kPa (kiloPascal) equals 0.145 psi.
- Device is ratiometric within this specified excitation range. Operating the device above the specified excitation range may induce additional error due to device self-heating.
- Full Scale Span (V_{FSS}) is defined as the algebraic difference between the output voltage at full rated pressure and the output voltage at the minimum rated pressure.
- Offset (V_{off}) is defined as the output voltage at the minimum rated pressure.
- Accuracy (error budget) consists of the following:
 - Linearity: Output deviation from a straight line relationship with pressure, using end point method, over the specified pressure range.
 - Temperature Hysteresis: Output deviation at any temperature within the operating temperature range, after the temperature is cycled to and from the minimum or maximum operating temperature points, with zero differential pressure applied.
 - Pressure Hysteresis: Output deviation at any pressure within the specified range, when this pressure is cycled to and from the minimum or maximum rated pressure, at 25°C .
 - TcSpan: Output deviation at full rated pressure over the temperature range of 0 to 85°C , relative to 25°C .
 - TcOffset: Output deviation with minimum rated pressure applied, over the temperature range of 0 to 85°C , relative to 25°C .
- Response Time is defined as the time for the incremental change in the output to go from 10% to 90% of its final value when subjected to a specified step change in pressure.
- Offset stability is the product's output deviation when subjected to 1000 hours of Pulsed Pressure, Temperature Cycling with Bias Test.

4 Maximum Ratings

Table 3. Maximum Ratings⁽¹⁾

Rating	Symbol	Value	Unit
Maximum Pressure (P1 > P2)	P _{max}	200	kPa
Storage Temperature	T _{stg}	-40 to +125	°C
Operating Temperature	T _A	-40 to +125	°C

1. Exposure beyond the specified limits may cause permanent damage or degradation to the device.

5 LINEARITY

Linearity refers to how well a transducer's output follows the equation: $V_{out} = V_{off} + \text{sensitivity} \times P$ over the operating pressure range. There are two basic methods for calculating nonlinearity: (1) end point straight line fit (see Figure 2) or (2) a least squares best line fit. While a least squares fit gives the "best case" linearity error (lower numerical value), the calculations required are burdensome. Conversely, an end point fit will give the "worst case" error (often more desirable in error budget calculations) and the calculations are more straightforward for the user. Motorola's specified pressure sensor linearities are based on the end point straight line method measured at the midrange pressure.

Figure 2. Linearity Specification Comparison

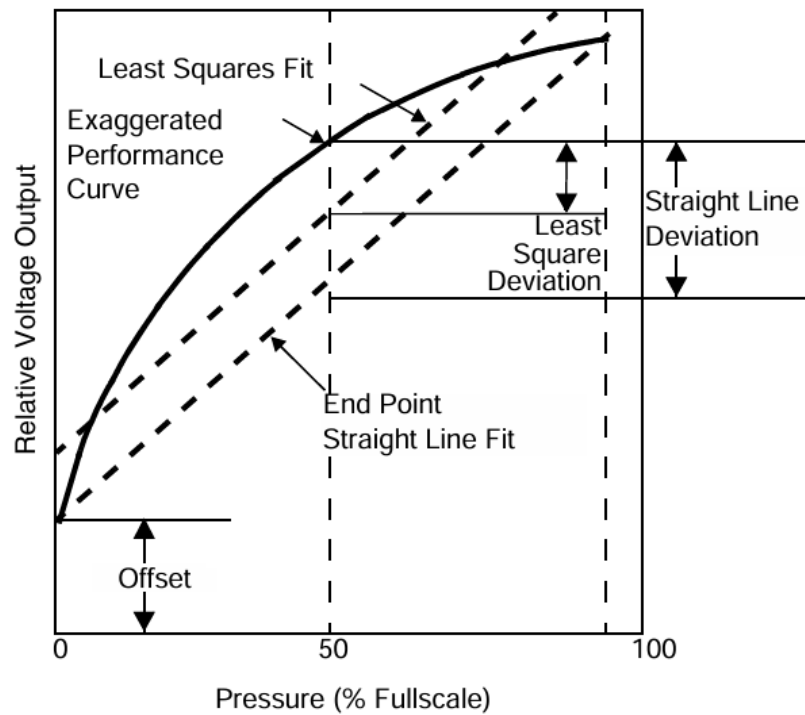

6 On-Chip Temperature Compensation and Calibration

Figure 3 shows the minimum, maximum and typical output characteristics of the MPX2050 series at 25°C. The output is directly proportional to the differential pressure and is essentially a straight line. The effects of temperature on Full-Scale Span and Offset are very small and are shown under Operating Characteristics.

Figure 3. Output versus Pressure Differential

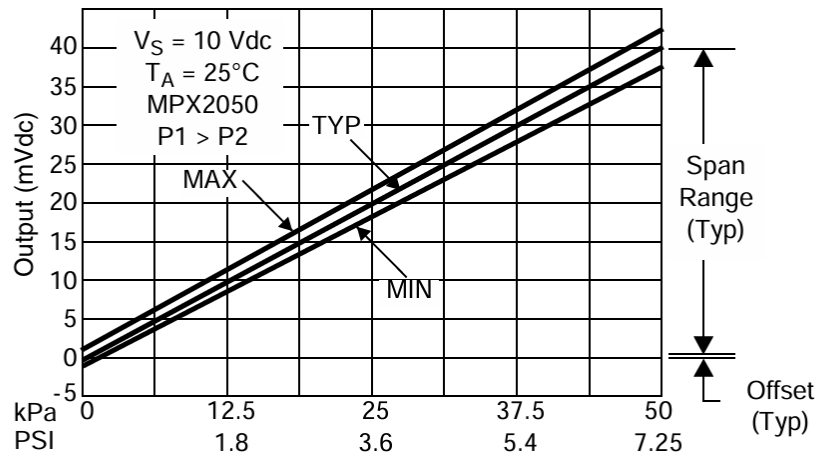

Figure 4. Cross-Sectional Diagram (not to scale)

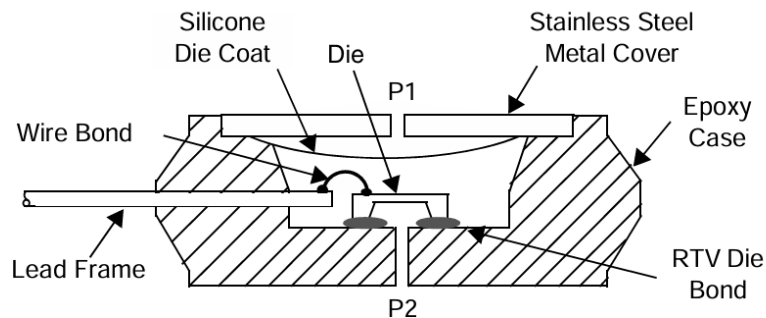

Figure 4 illustrates the differential or gauge configuration in the basic chip carrier (Case 344). A silicone gel isolates the die surface and wire bonds from the environment, while allowing the pressure signal to be transmitted to the silicon diaphragm. The MPX2050 series pressure sensor operating characteristics and internal reliability and qualification tests are based on use of dry air as the pressure media. Media other than dry air may have adverse effects on sensor performance and long term reliability. Contact the factory for information regarding media compatibility in your application.



7 PRESSURE (P1) / VACUUM (P2) SIDE IDENTIFICATION TABLE

ST designates the two sides of the pressure sensor as the Pressure (P1) side and the Vacuum (P2) side. The Pressure (P1) side is the side containing the silicone gel which isolates the die. The pressure sensor is designed to operate with positive differential pressure applied, $P1 > P2$. The Pressure (P1) side may be identified by using the following table.

Table 4. Pressure (P1) Side Delineation

Part Number	Case Type	Pressure (P1) Side Identifier
MPX2050D	344	Stainless Steel Cap
MPX2050DP	344C	Side with Part Marking
MPX2050GP	344B	Side with Port Attached

8 PACKAGE DIMENSIONS

Figure 5. CASE 344-15 ISSUE AA UNIBODY PACKAGE

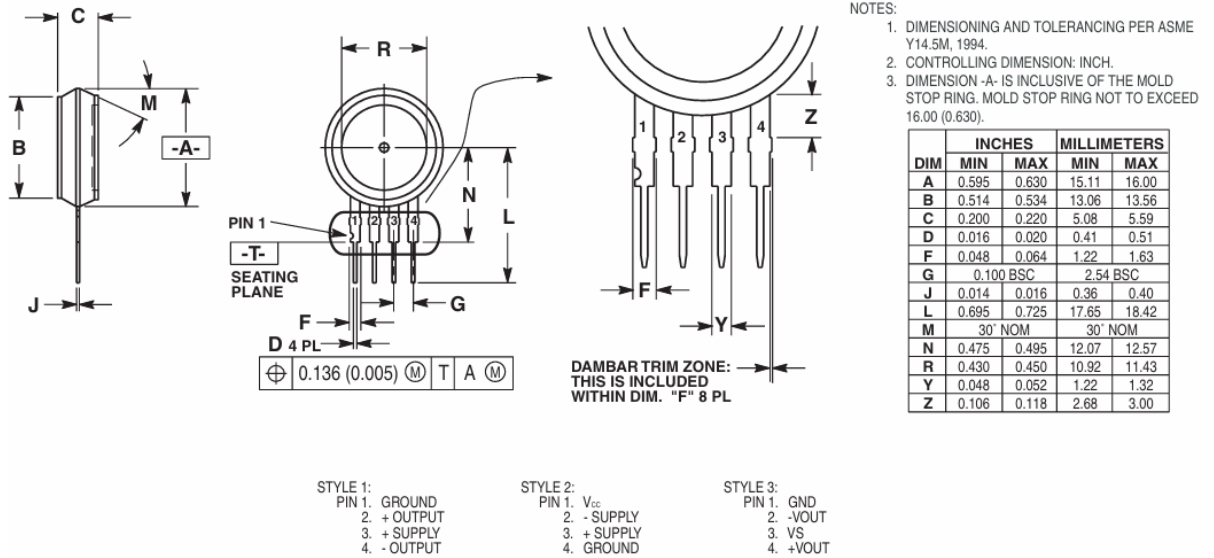

Figure 6. CASE 344B-01 ISSUE B UNIBODY PACKAGE

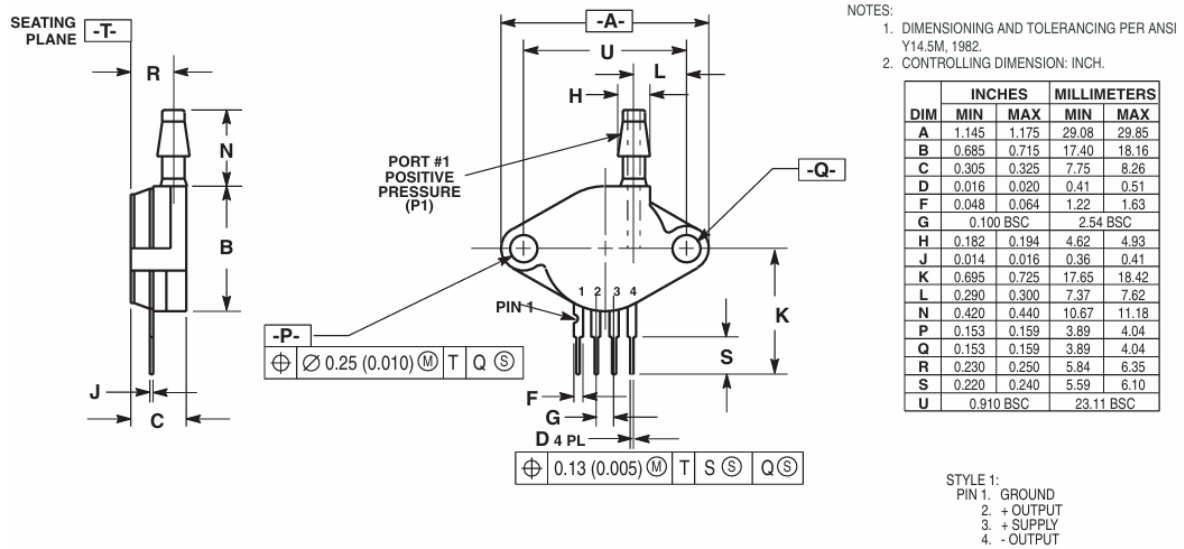
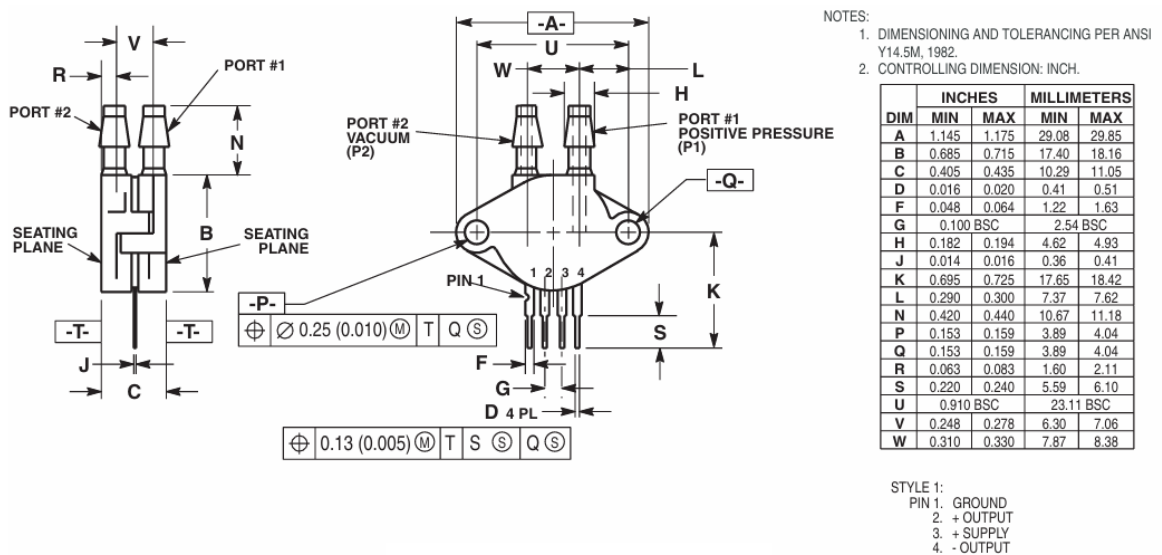

Figure 7. CASE 344C-01 ISSUE B UNIBODY PACKAGE



Revision history

Table 5. Document revision history

Date	Version	Changes
23-Jun-2026	1	Initial release from ST, rebranded NXP document



Contents

1	Ordering Information	2
2	Voltage Output versus Applied Differential Pressure	3
3	Operating Characteristics	4
4	Maximum Ratings	5
5	LINEARITY	6
6	On-Chip Temperature Compensation and Calibration	7
7	PRESSURE (P1) / VACUUM (P2) SIDE IDENTIFICATION TABLE	8
8	PACKAGE DIMENSIONS	9
	Revision history	11



IMPORTANT NOTICE – READ CAREFULLY

STMicroelectronics NV and its subsidiaries (“ST”) reserve the right to make changes, corrections, enhancements, modifications, and improvements to ST products and/or to this document at any time without notice.

In the event of any conflict between the provisions of this document and the provisions of any contractual arrangement in force between the purchasers and ST, the provisions of such contractual arrangement shall prevail.

The purchasers should obtain the latest relevant information on ST products before placing orders. ST products are sold pursuant to ST’s terms and conditions of sale in place at the time of order acknowledgment.

The purchasers are solely responsible for the choice, selection, and use of ST products and ST assumes no liability for application assistance or the design of the purchasers’ products.

No license, express or implied, to any intellectual property right is granted by ST herein.

Resale of ST products with provisions different from the information set forth herein shall void any warranty granted by ST for such product.

If the purchasers identify an ST product that meets their functional and performance requirements but that is not designated for the purchasers’ market segment, the purchasers shall contact ST for more information.

ST and the ST logo are trademarks of ST. For additional information about ST trademarks, refer to www.st.com/trademarks. All other product or service names are the property of their respective owners.

Information in this document supersedes and replaces information previously supplied in any prior versions of this document.

© 2026 STMicroelectronics – All rights reserved