

## 10 kPa uncompensated pressure sensors

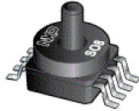

MPX10D  
Case 344-15



MPXV10GC6U  
Case 482A-01



MPX10GP  
Case 344B-01



MPX10DP  
Case 344C-01

### Features

- Low Cost
- Patented Silicon Shear Stress Strain Gauge Design
- Ratiometric to Supply Voltage
- Differential and Gauge Options
- Durable Epoxy Unibody Element or Thermoplastic (PPS) Surface Mount Package

### Applications

- Air Movement Control
- Environmental Control Systems
- Level Indicators
- Leak Detection
- Medical Diagnostics
- Industrial Controls
- Pneumatic Control Systems
- Robotics

### Description

The MPX10 series device is a silicon piezoresistive pressure sensor providing a very accurate and linear voltage output directly proportional to the applied pressure. This standard, low cost, uncompensated sensor permits manufacturers to design and add their own external temperature compensation and signal conditioning networks. Compensation techniques are simplified because of the predictability of ST's single element strain gauge design.

## 1 Ordering Information

Table 1. Ordering information

Device Name	Package options	Case number	Number of ports			Pressure type			Device marking
			None	Single	Dual	Gauge	Differential	Absolute	
Small outline package (MPX10 Series)									
MPXV10GC6U	Rail	<a href="#">482A</a>		•		•			MPXV10G
Unibody package (MPX10 Series)									
MPX10D	Tray	<a href="#">344</a>	•				•		MPX10D
MPX10DP	Tray	<a href="#">344C</a>			•		•		MPX10DP
MPX10GP	Tray	<a href="#">344B</a>		•		•			MPX10GP

## 2 Block Diagram

Figure 1 shows a schematic of the internal circuitry on the stand-alone pressure sensor chip.

**Figure 1. Uncompensated pressure sensor schematic**

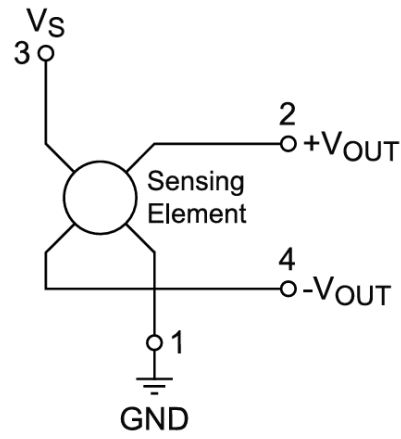

aaa-037710

### 3 Pin Information

#### MPXV10GC6U

Figure 2. Case 482A-01

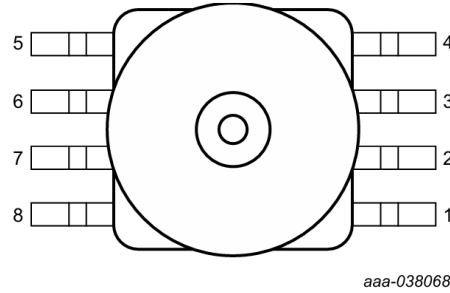
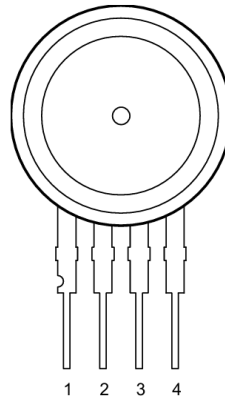

Table 2. Pin definitions - MPXV10GC6U

Symbol	Pin	Description
GND	1	Ground
+V <sub>OUT</sub>	2	+Voltage output
V <sub>S</sub>	3	Power supply
-V <sub>OUT</sub>	4	-Voltage output
n.c.	5	Not connected
n.c.	6	Not connected
n.c.	7	Not connected
n.c.	8	Not connected

**MPX10D**

**Figure 3. Case 344-15**



aaa-037831

**Table 3. Pin definitions - MPX10D**

Symbol	Pin	Description
GND	1	Ground
+V <sub>OUT</sub>	2	+ Voltage output
V <sub>S</sub>	3	Power supply
-V <sub>OUT</sub>	4	- Voltage output

**MPX10DP**

**Figure 4. Case 344C-01**

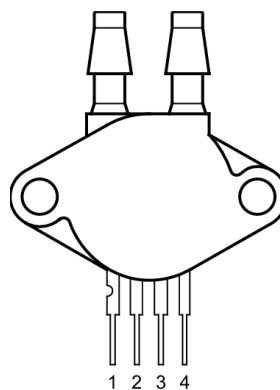

aaa-037859

**Table 4. Pin definitions - MPX10D**

Symbol	Pin	Description
GND	1	Ground
+V <sub>OUT</sub>	2	+ Voltage output
V <sub>S</sub>	3	Power supply
-V <sub>OUT</sub>	4	- Voltage output

MPX10GP

Figure 5. Case 344B-01

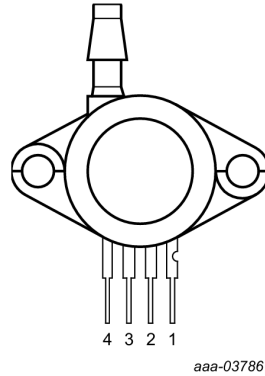

Table 5. Pin definitions - MPX10GP

Symbol	Pin	Description
GND	1	Ground
+V <sub>OUT</sub>	2	+ Voltage output
V <sub>S</sub>	3	Power supply
-V <sub>OUT</sub>	4	- Voltage output

## 4 Maximum Ratings

*Exposure beyond the specified limits may cause permanent damage or degradation to the device.  
In accordance with the Absolute Maximum Rating System (IEC 60134).*

**Table 6. Maximum ratings**

Symbol	Parameter	Conditions	Min	Typ	Max	Unit
P <sub>max</sub>	Overpressure	P1 > P2	—	—	75	kPa
P <sub>burst</sub>	Burst Pressure	P1 > P2	—	—	100	kPa
T <sub>stg</sub>	Storage Temperature		-40	—	+125	°C
T <sub>A</sub>	Operating Temperature		-40	—	+125	°C

## 5 Operating Characteristics

**Table 7. Operating Characteristics ( $V_S = 3.0$  Vdc,  $T_A = 25$  °C unless otherwise noted,  $P_1 > P_2$ )**

Characteristic		Symbol	Min	Typ	Max	Unit
Operating Pressure Range	[1]	$P_{OP}$	0	—	10	kPa
Supply Voltage	[2]	$V_S$	—	3.0	6.0	$V_{DC}$
Supply Current		$I_o$	—	6.0	—	$m_{Adc}$
Full Scale Span	[3]	$V_{FSS}$	20	35	50	mV
Offset	[4]	$V_{off}$	0	20	35	mV
Sensitivity		$\Delta V/\Delta P$	—	3.5	—	mV/kPa
Linearity	[5]	—	-1.0	—	1.0	% $V_{FSS}$
Pressure Hysteresis (0 kPa to 10 kPa)	[5]	—	—	$\pm 0.1$	—	% $V_{FSS}$
Temperature Hysteresis (-40 °C to +125 °C)	[5]	—	—	$\pm 0.5$	—	% $V_{FSS}$
Temperature Coefficient of Full Scale Span	[5]	$TCV_{FSS}$	-0.22	—	-0.16	% $V_{FSS}/^{\circ}C$
Temperature Coefficient of Offset	[5]	$TCV_{off}$	—	$\pm 15$	—	$\mu V/^{\circ}C$
Temperature Coefficient of Resistance	[5]	TCR	0.21	—	0.27	% $Z_{in}/^{\circ}C$
Input Impedance		$Z_{in}$	400	—	550	$\Omega$
Output Impedance		$Z_{out}$	750	—	1250	$\Omega$
Response Time (10% to 90%)	[6]	$t_R$	—	1.0	—	ms
Warm-Up Time	[7]	—	—	20	—	ms
Offset Stability	[8]	—	—	$\pm 0.5$	—	% $V_{FSS}$

1. 1.0 kPa equals 0.145 PSI.
2. Device is ratiometric within this specified excitation range. Operating the device above the specified excitation range may induce additional error due to device self-heating.
3. Full Scale Span ( $V_{FSS}$ ) is defined as the algebraic difference between the output voltage at full rated pressure and the output voltage at the minimum rated pressure.
4. Offset ( $V_{off}$ ) is defined as the output voltage at the minimum rated pressure.
5. Accuracy (error budget) consists of the following:
  - Linearity: Output deviation from a straight line relationship with pressure, using the end point method, over the specified pressure range.
  - Temperature Hysteresis: Output deviation at any temperature within the operating temperature range, after the temperature is cycled to and from the minimum or maximum operating temperature points, with zero differential pressure applied.
  - Pressure Hysteresis: Output deviation at any pressure within the specified range, when this pressure is cycled to and from the minimum or maximum rated pressure, at 25 °C.
  - TcSpan: Output deviation at full rated pressure over the temperature range of 0 °C to 85 °C, relative to 25 °C
  - TcOffset: Output deviation with minimum rated pressure applied, over the temperature range of 0 °C to 85 °C, relative to 25 °C
  - TCR:  $Z_{in}$  deviation with minimum rated pressure applied, over the temperature range of -40 °C to +125 °C, relative to 25 °C
6. Response Time is defined as the time for the incremental change in the output to go from 10% to 90% of its final value when subjected to a specified step change in pressure.
7. Warm-Up Time is defined as the time required for the product to meet the specified output voltage after the pressure has been stabilized.



8. Offset Stability is the product's output deviation when subjected to 1000 hours of Pulsed Pressure Temperature Cycling with Bias test.

## 6 Characteristics

### 6.1 Voltage output versus applied differential pressure

The output voltage of the differential or gauge sensor increases with increasing pressure applied to the pressure side (P1) relative to the vacuum side (P2). Similarly, output voltage increases as increasing vacuum is applied to the vacuum side (P2) relative to the pressure side (P1).

### 6.2 Temperature compensation

Figure 6 shows the typical output characteristics of the MPX10 series over temperature.

Because this strain gauge is an integral part of the silicon diaphragm, there are no temperature effects due to differences in the thermal expansion of the strain gauge and the diaphragm, as are often encountered in bonded strain gauge pressure sensors. However, the properties of the strain gauge itself are temperature dependent, requiring that the device be temperature compensated if it is to be used over an extensive temperature range.

Temperature compensation and offset calibration can be achieved rather simply with additional resistive components, or by designing your system using the MPX2010 series sensor.

Several approaches to external temperature compensation over both  $-40\text{ }^{\circ}\text{C}$  to  $+125\text{ }^{\circ}\text{C}$  and  $0\text{ }^{\circ}\text{C}$  to  $+80\text{ }^{\circ}\text{C}$  ranges are presented in Application Note AN840

Figure 6. Output vs. pressure differential

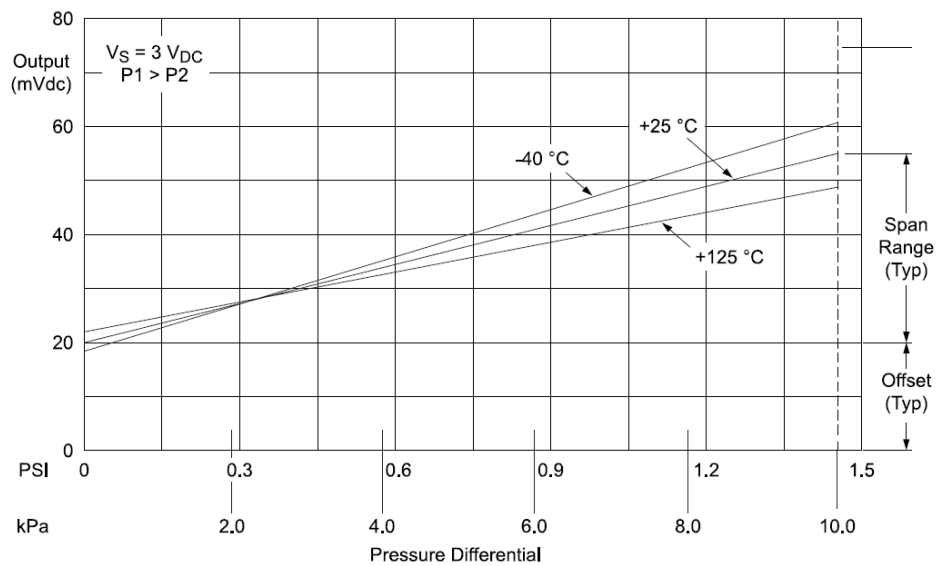

aaa-041234

### 6.3 Linearity

Linearity refers to how well a transducer's output follows the equation

$V_{out} = V_{off} + \text{Sensitivity} \times P$  over the operating pressure range (Figure 7). There are two basic methods for calculating nonlinearity:

- End point straight line fit
- Least squares best line fit

While a least squares fit gives the "best case" linearity error (lower numerical value), the calculations required are burdensome.

Conversely, an end point fit will give the "worst case" error (often more desirable in error budget calculations) and the calculations are more straightforward for the user.

ST's specified pressure sensor linearities are based on the end point straight line method measured at the midrange pressure.

Figure 7. Linearity specification comparison

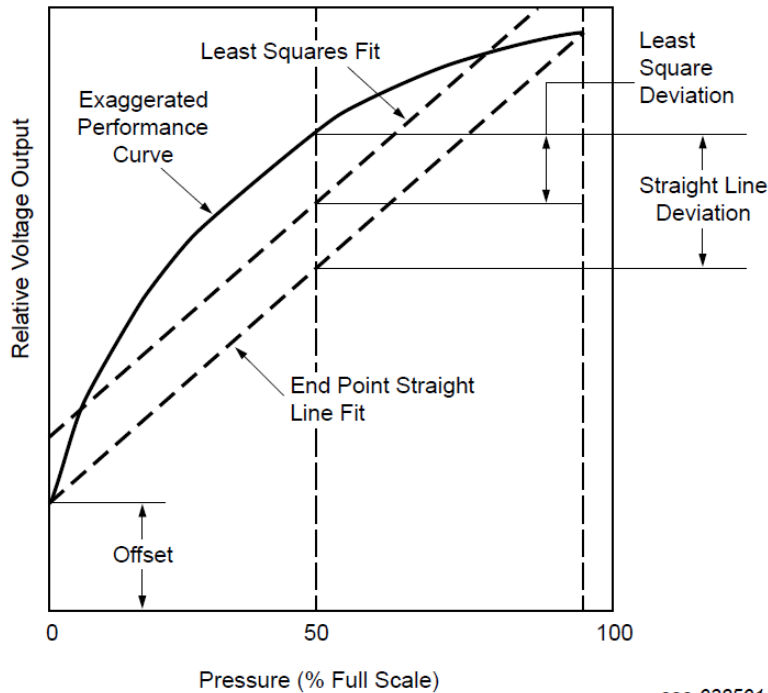

aaa-038501

### 6.4 Pressure (P1) / Vacuum (P2) side identification

ST designates the two sides of the pressure sensor as the Pressure (P1) side and the Vacuum (P2) side. The Pressure (P1) side is the side containing silicone gel that isolates the die from the environment. The ST MPX pressure sensor is designed to operate with positive differential pressure applied,  $P1 > P2$ .

The Pressure (P1) side may be identified by using [Table 8](#).

Table 8. Pressure (P1) side delineation table

Part Number	Case Type	Pressure (P1) Side Identifier
MPX10D	344	Stainless Steel Cap
MPX10DP	344C	Side with Part Marking
MPX10GP	344B	Side with Port Attached
MPXV10GC6U	482A	Side with Port Attached

### 6.5 Media compatibility

Figure 8 illustrates the differential or gauge configuration in a typical chip carrier. A silicone gel isolates the die surface and wire bonds from the environment while allowing the pressure signal to be transmitted to the silicon diaphragm.

The MPX10 series pressure sensor operating characteristics, internal reliability and qualification tests are based on the use of dry clean air as the pressure medium. Media other than dry clean air may have adverse effects on sensor performance and long term reliability. Contact the factory for information regarding media compatibility in your application.

For more information, refer to application note AN3728.

Figure 8. Unibody package — cross-sectional diagram (not to scale)

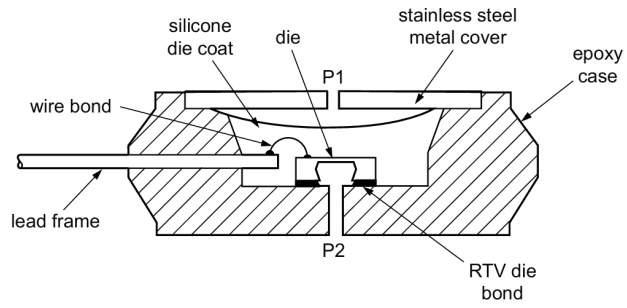

aaa-037713

## 7 Package Outlines

### 7.1 Small outline packages

Figure 9. SOT1854-1 (Case 482A)

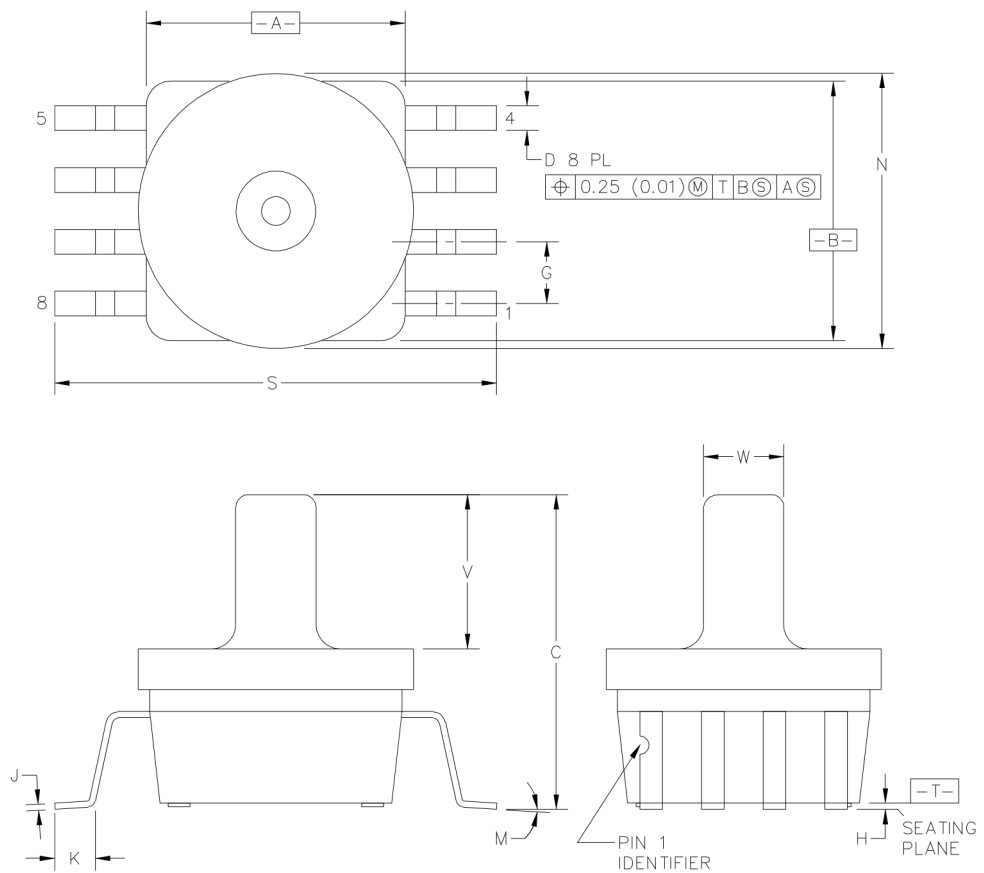

© NXP SEMICONDUCTORS N.V. ALL RIGHTS RESERVED	MECHANICAL OUTLINE	PRINT VERSION NOT TO SCALE
TITLE: SENSOR UNIBODY, 11.33 X 11.33 X 12.955 PKG, 2.54 PITCH, 8 I/O	DOCUMENT NO: 98ASB17757C	REV: C
	STANDARD: NON-JEDEC	
	SOT1854-1	13 JUL 2017

Figure 10. SOT1854-1 (Case 482A)

NOTES:

1. DIMENSIONING AND TOLERANCING PER ANSI Y14.5M-1982.
2. CONTROLLING DIMENSION: INCH.
3. DIMENSION 'A' AND 'B' DO NOT INCLUDE MOLD PROTUSION.
4. MAXIMUM MOLD PROTRUSION 0.15 (0.006).
5. ALL VERTICAL SURFACES 5° TYPICAL DRAFT.

DIM	INCHES		MILLIMETERS	
	MIN	MAX	MIN	MAX
A	0.415	0.425	10.54	10.79
B	0.415	0.425	10.54	10.79
C	0.500	0.520	12.70	13.21
D	0.038	0.042	0.96	1.07
G	0.100	BSC	2.54	BSC
H	0.002	0.010	0.05	0.25
J	0.009	0.011	0.23	0.28
K	0.061	0.071	1.55	1.80
M	0°	7°	0°	7°
N	0.444	0.448	11.28	11.38
S	0.709	0.725	18.01	18.41
V	0.245	0.255	6.22	6.48
W	0.115	0.125	2.92	3.17

© NXP SEMICONDUCTORS N.V. ALL RIGHTS RESERVED		MECHANICAL OUTLINE	PRINT VERSION NOT TO SCALE
TITLE: SENSOR UNIBODY, 11.33 X 11.33X 12.955 PKG, 2.54 PITCH, 8 I/O		DOCUMENT NO: 98ASB17757C	REV: C
		STANDARD: NON-JEDEC	
		SOT1854-1	13 JUL 2017

## 7.2 Unibody packages

Figure 11. SOT1753-1 (Case 344B-01)

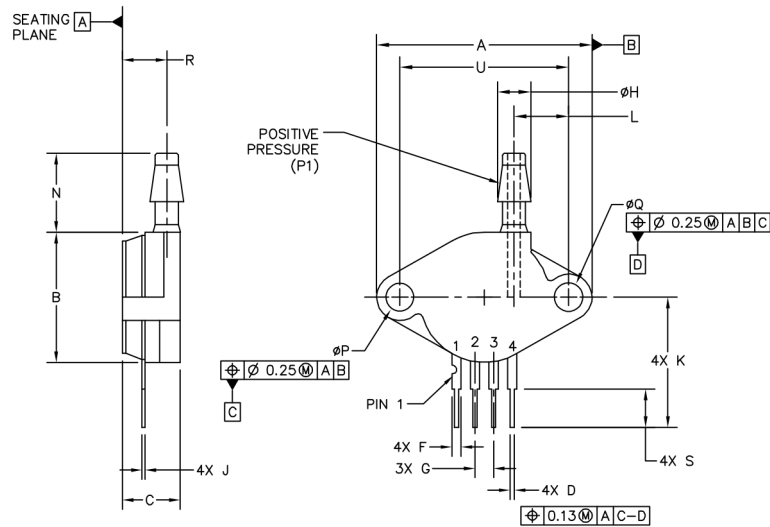

DIM	MILLIMETERS		DIM	MILLIMETERS		NOTES: 1. DIMENSIONS ARE IN MILLIMETERS. 2. DIMENSIONS AND TOLERANCES PER ASME Y14.5M-1994. 3. STYLE 1: PIN 1: GROUND 2: + OUTPUT 3: + SUPPLY 4: - OUTPUT
	MIN	MAX		MIN	MAX	
A	29.08	29.85	P	3.89	4.04	
B	17.40	18.16	Q	3.89	4.04	
C	7.75	8.26	R	5.84	6.35	
D	0.41	0.51	S	5.59	6.10	
F	1.22	1.63	U	23.11	BASIC	
G	2.54 BASIC					
H	4.62	4.93				
J	0.36	0.41				
K	17.65	18.42				
L	7.37	7.62				
N	10.67	11.18				

© NXP SEMICONDUCTORS N.V.  
ALL RIGHTS RESERVED

MECHANICAL OUTLINE

PRINT VERSION NOT TO SCALE

TITLE:

SENSOR, 4 LEAD UNIBODY

DOCUMENT NO: 98ASB14911C

REV: E

STANDARD: NON-JEDEC

SOT1753-1

18 JAN 2016

Figure 12. SOT1754-1 (Case 344C-01)

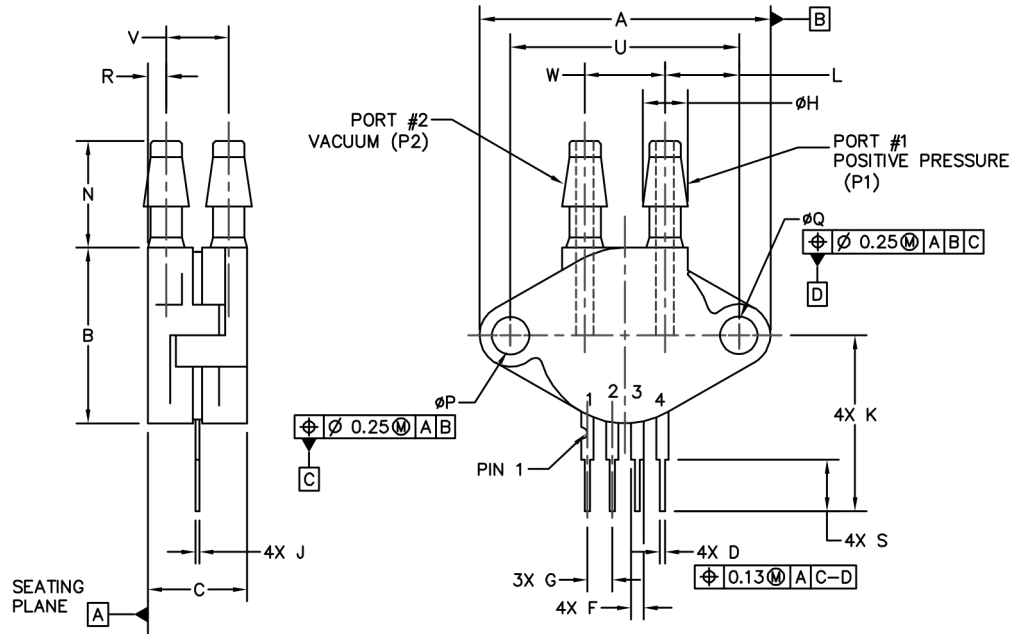

DIM	MILLIMETERS		DIM	MILLIMETERS		NOTES: 1. DIMENSIONS ARE IN MILLIMETERS. 2. DIMENSIONS AND TOLERANCES PER ASME Y14.5M-1994. 3. STYLE 1:  PIN 1: GROUND 2: + OUTPUT 3: + SUPPLY 4: - OUTPUT
	MIN	MAX		MIN	MAX	
A	29.08	29.85	N	10.67	11.18	
B	17.40	18.16	P	$\phi 3.89$	$\phi 4.04$	
C	10.29	11.05	Q	$\phi 3.89$	$\phi 4.04$	
D	0.41	0.51	R	1.60	2.11	
F	1.22	1.63	S	5.59	6.10	
G	2.54 BSC		U	23.11 BSC		
H	$\phi 4.62$	$\phi 4.93$	V	6.30	7.06	
J	0.36	0.41	W	7.89	8.38	
K	17.65	18.42				
L	7.37	7.62				
© NXP SEMICONDUCTORS N.V. ALL RIGHTS RESERVED			MECHANICAL OUTLINE		PRINT VERSION NOT TO SCALE	
TITLE: SENSOR, 4 LEAD UNIBODY			DOCUMENT NO: 98ASB14912C		REV: E	
			STANDARD: NON-JEDEC			
			SOT1754-1		18 JAN 2016	

Figure 13. SOT1772-1 (Case 344-15)

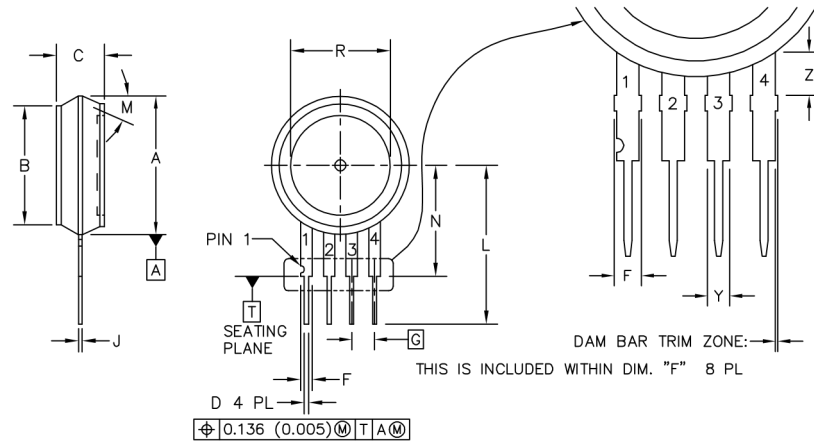

DIM	MILLIMETERS		INCHES	
	MIN	MAX	MIN	MAX
A	15.11	16.00	0.595	0.630
B	13.06	13.56	0.514	0.534
C	5.08	5.59	0.200	0.220
D	0.41	0.51	0.016	0.020
F	1.22	1.63	0.048	0.064
G	2.54 BSC		0.100 BSC	
J	0.36	0.40	0.014	0.016
L	17.65	18.42	0.695	0.725
M	30° NOM		30° NOM	
N	12.07	12.57	0.475	0.495
R	10.92	11.43	0.430	0.450
Y	1.22	1.32	0.048	0.052
Z	2.68	3.00	0.106	0.118

NOTES:

1. DIMENSIONING AND TOLERANCING PER ASME Y14.5M, 1994
2. CONTROLLING DIMENSION: INCH.
3. DIMENSION A IS INCLUSIVE OF THE MOLD STOP RING NOT TO EXCEED 16.00 (0.630)
4. 344-01 THRU -4 OBSOLETE.
5. 344-05 THRU -11 OBSOLETE, NEW STANDARD 344-15.

STYLE 1:

- PIN
1. GROUND
  2. + OUTPUT
  3. + SUPPLY
  4. - OUTPUT

STYLE 2:

- PIN
1. VCC
  2. - SUPPLY
  3. + SUPPLY
  4. GROUND

STYLE 3:

- PIN
1. GROUND
  2. - VOUT
  3. VS
  4. + VOUT

© NXP SEMICONDUCTORS N.V. ALL RIGHTS RESERVED	<b>MECHANICAL OUTLINE</b>	PRINT VERSION NOT TO SCALE	
TITLE:  UNIBODY A & D	DOCUMENT NO: 98ASB42280B		REV: AD
	STANDARD: NON-JEDEC		
	SOT1772-1		02 FEB 2016

## Revision history

**Table 9. Document revision history**

Date	Version	Changes
20-May-2026	1	Initial release from ST, rebranded NXP document

## Contents

<b>1</b>	<b>Ordering Information</b> .....	<b>2</b>
<b>2</b>	<b>Block Diagram</b> .....	<b>3</b>
<b>3</b>	<b>Pin Information</b> .....	<b>4</b>
<b>4</b>	<b>Maximum Ratings</b> .....	<b>7</b>
<b>5</b>	<b>Operating Characteristics</b> .....	<b>8</b>
<b>6</b>	<b>Characteristics</b> .....	<b>10</b>
<b>6.1</b>	Voltage output versus applied differential pressure .....	10
<b>6.2</b>	Temperature compensation .....	10
<b>6.3</b>	Linearity .....	10
<b>6.4</b>	Pressure (P1) / Vacuum (P2) side identification .....	11
<b>6.5</b>	Media compatibility .....	11
<b>7</b>	<b>Package Outlines</b> .....	<b>13</b>
<b>7.1</b>	Small outline packages .....	13
<b>7.2</b>	Unibody packages .....	15
	<b>Revision history</b> .....	<b>18</b>

**IMPORTANT NOTICE – READ CAREFULLY**

STMicroelectronics NV and its subsidiaries (“ST”) reserve the right to make changes, corrections, enhancements, modifications, and improvements to ST products and/or to this document at any time without notice.

In the event of any conflict between the provisions of this document and the provisions of any contractual arrangement in force between the purchasers and ST, the provisions of such contractual arrangement shall prevail.

The purchasers should obtain the latest relevant information on ST products before placing orders. ST products are sold pursuant to ST’s terms and conditions of sale in place at the time of order acknowledgment.

The purchasers are solely responsible for the choice, selection, and use of ST products and ST assumes no liability for application assistance or the design of the purchasers’ products.

No license, express or implied, to any intellectual property right is granted by ST herein.

Resale of ST products with provisions different from the information set forth herein shall void any warranty granted by ST for such product.

If the purchasers identify an ST product that meets their functional and performance requirements but that is not designated for the purchasers’ market segment, the purchasers shall contact ST for more information.

ST and the ST logo are trademarks of ST. For additional information about ST trademarks, refer to [www.st.com/trademarks](http://www.st.com/trademarks). All other product or service names are the property of their respective owners.

Information in this document supersedes and replaces information previously supplied in any prior versions of this document.

© 2026 STMicroelectronics – All rights reserved