

-50 to 0 kPa, gauge pressure sensor

Small outline package

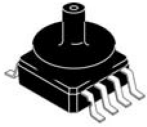

MP3V5050V
Case 98ASB17757C

Top view

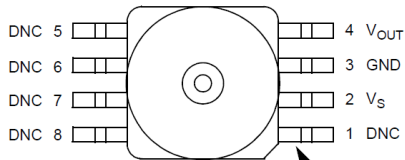

Pin 1 identification: notch

Pinout

Features

- 2.5% maximum error over 0 °C to 85 °C
- Ideally suited for microprocessor or microcontroller-based systems
- Temperature compensated over -40 °C to +125 °C
- Patented silicon shear stress strain gauge
- Durable thermoplastic (PPS) surface mount package

Applications

- Pump/motor control
- Robotics
- Level detectors
- Medical diagnostics
- Pressure switching
- Blood pressure measurement

Description

The MP3V5050V piezoresistive transducer is a state-of-the-art, monolithic, signal conditioned, silicon pressure sensor. This sensor combines advanced micromachining techniques, thin film metallization, and bipolar semiconductor processing to provide an accurate, high level analog output signal that is proportional to applied pressure. The MP3V5050V is optimized to perform with vacuum pressures on the P1 port.

1 General Description

1.1 Ordering information

Table 1. Ordering informations

Ordering Information								
Part number	Shipping	Package	# of Ports			Pressure type		Device marking
			None	Single	Dual	Gauge	Differential	
MP3V5050VC6U	Rail	98ASB17757C		•		•		MP3V5050V

1.2 Block diagram

Figure 1 shows a block diagram of the internal circuitry integrated on a pressure sensor chip.

Figure 1. Fully integrated pressure sensor block diagram

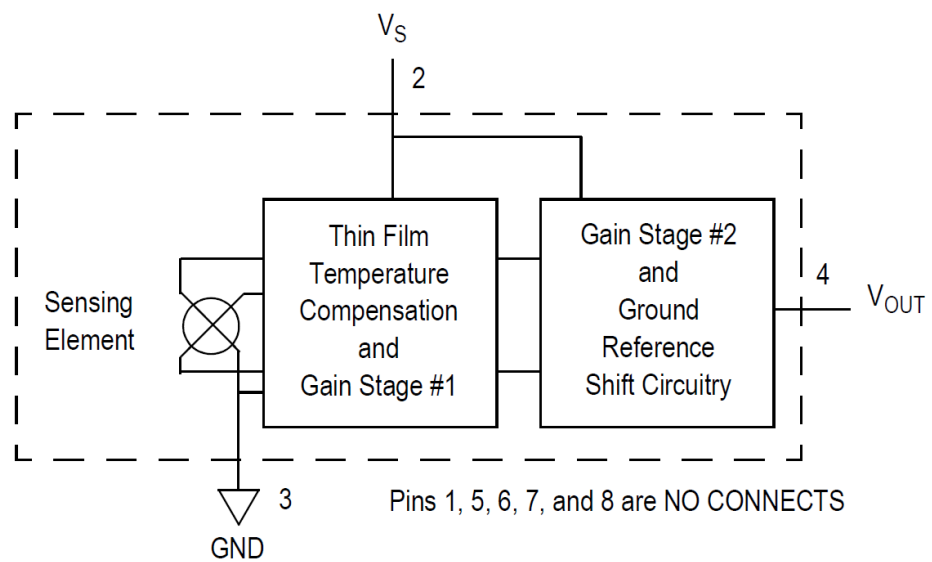

1.3 Pinout

Figure 2. Device pinout (top view)

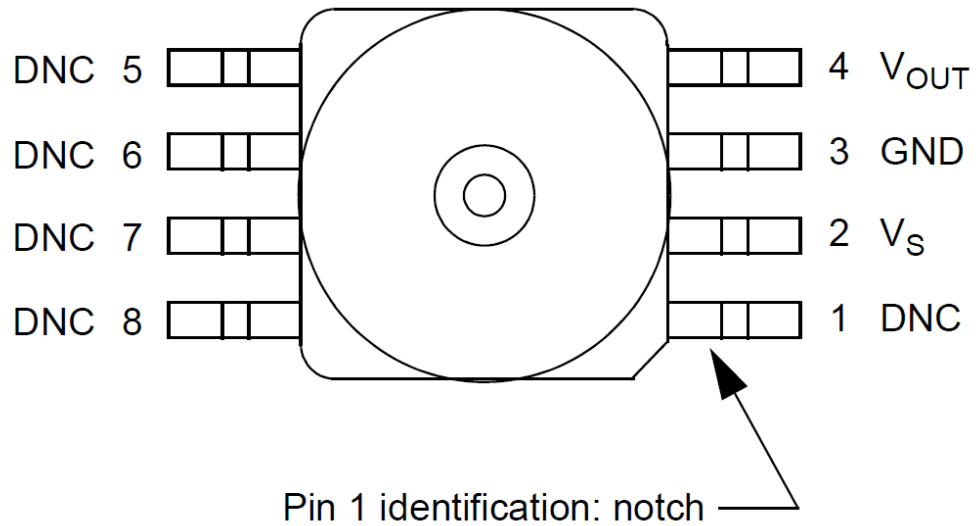

Table 2. Pin functions

Pin	Name	Function
1	DNC	Do not connect to external circuitry or ground. Pin 1 is notated by the notch in the lead.
2	V_S	Voltage supply
3	GND	Ground
4	V_{OUT}	Output voltage
5	DNC	Do not connect to external circuitry or ground.
6	DNC	Do not connect to external circuitry or ground.
7	DNC	Do not connect to external circuitry or ground.
8	DNC	Do not connect to external circuitry or ground.

2 Mechanical and Electrical Specifications

2.1 Maximum ratings

Table 3. Maximum ratings⁽¹⁾

Rating	Symbol	Value	Unit
Maximum pressure (P1 > P2)	P _{max}	200	kPa
Storage temperature	T _{stg}	-40° to +125°	°C
Operating temperature	T _A	-40° to +125°	°C

1. Exposure beyond the specified limits may cause permanent damage or degradation to the device.

2.2 Operating characteristics

Table 4. Operating characteristics (V_S = 3.0 V_{DC}, T_A = 25 °C unless otherwise noted, P1 > P2)

Characteristic	Symbol	Min	Typ	Max	Unit
Pressure range	P _{OP}	-50	—	0	kPa
Supply voltage ⁽¹⁾	V _S	2.7	3.0	3.3	V _{DC}
Supply current	I _O	—	7.0	10	mAdc
Full-scale output ⁽²⁾ (0° to 85°C) @ V _S = 3.0 Volts, (P _{diff} = 0 kPa)	V _{FSSO}	2.7	2.8	2.9	V _{DC}
Full-scale span ⁽³⁾ (0 °C to 85 °C) @ V _S = 3.0 Volts	V _{FSS}	—	2.7	—	V _{DC}
Accuracy ⁽⁴⁾ (0 °C to 85 °C)	—	—	—	±2.5	%V _{FSS}
Sensitivity	V/P	—	54	—	mV/kPa
Response time ⁽⁵⁾	t _R	—	1.0	—	ms
Warm-up time ⁽⁶⁾	—	—	20	—	ms
Offset stability ⁽⁷⁾	—	—	±0.5	—	%V _{FSS}
Pressure offset ⁽⁸⁾ (0 °C to 85 °C)	V _{OFF}	0.06	0.12	0.19	V _{DC}

1. Device is ratiometric within this specified excitation range.
2. Full-scale output (V_{FSSO}) is defined as the output voltage at the maximum or full-rated pressure.
3. Full-scale span (V_{FSS}) is defined as the algebraic difference between the output voltage at full-rated pressure and the output voltage at the minimum rated pressure.
4. Accuracy is the deviation in actual output from nominal output over the entire pressure range and temperature range as a percent of span at 25 °C due to all sources of errors, including the following:
 Linearity: Output deviation from a straight line relationship with pressure over the specified pressure range.
 Temperature hysteresis: Output deviation at any temperature within the operating temperature range, after the temperature is cycled to and from the minimum or maximum operating temperature points, with zero differential pressure applied.
 Pressure hysteresis: Output deviation at any pressure within the specified range, when this pressure is cycled to and from minimum or maximum rated pressure at 25 °C.
 TcSpan: Output deviation over the temperature range of 0 °C to 85 °C, relative to 25 °C.
 TcOffset: Output deviation with minimum pressure applied, over the temperature range of 0 °C to 85 °C, relative to 25 °C.

5. Response time is defined as the time for the incremental change in the output to go from 10% to 90% of its final value when subjected to a specified step change in pressure.
6. Warm-up time is defined as the time required for the product to meet the specified output voltage after the pressure has been stabilized.
7. Offset stability is the product's output deviation when subjected to 1000 hours of pulsed pressure, temperature cycling with bias test.
8. Offset (V_{OFF}) is defined as the output voltage at the minimum rated pressure.

3 On-chip Temperature Compensation and Calibration

Figure 3 illustrates the differential/gauge sensing chip in the basic chip carrier.

Figure 4 shows the recommended decoupling circuit for interfacing the output of the integrated sensor to the A/D input of a microprocessor or microcontroller. Proper decoupling of the power supply is recommended.

Figure 5 shows the sensor output signal relative to pressure input. Typical minimum and maximum output curves are shown for operation over 0 °C to 85 °C temperature range. The output will saturate outside of the rated pressure range.

A fluorosilicone gel isolates the die surface and wire bonds from the environment, while allowing the pressure signal to be transmitted to the silicon diaphragm. The MP3V5050V pressure sensor operating characteristics, internal reliability and qualification tests are based on use of dry air as the pressure media. Media other than dry air may have adverse effects on sensor performance and long-term reliability. Contact the factory for information regarding media compatibility in your application.

The MP3V5050V is optimized to perform in vacuum pressures applied to port P1. The sensor is calibrated and temperature compensated to give a positive electrical output upon measuring a vacuum pressure up to the rated pressure of up to -50 kPa where the output will be the full-scale voltage listed in Table 4.

Figure 3. Cross-sectional diagram SOP (not-to-scale)

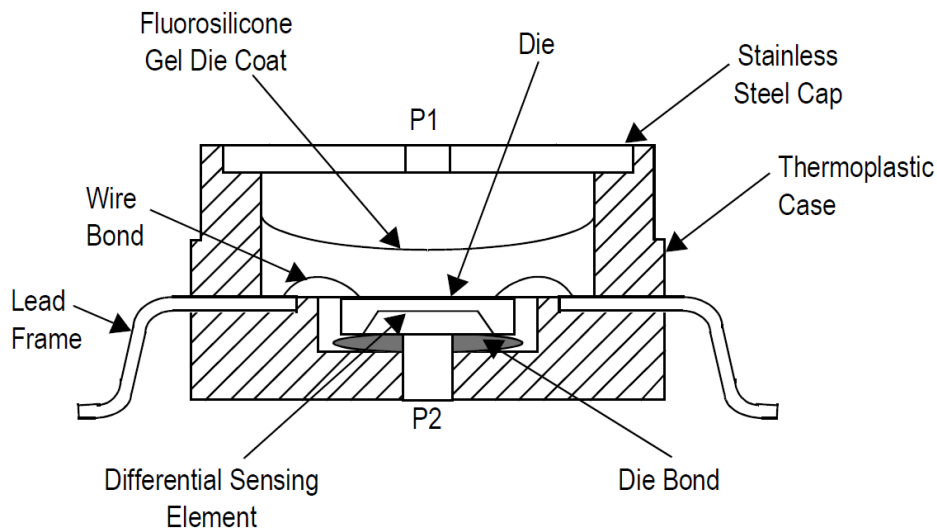

Figure 4. Recommended power supply decoupling and output filtering

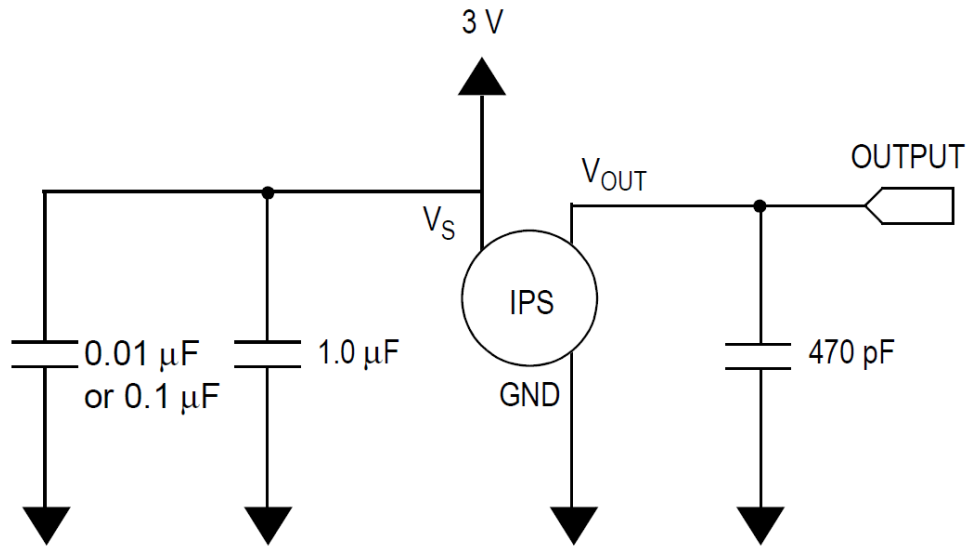

Figure 5. Output vs. pressure differential

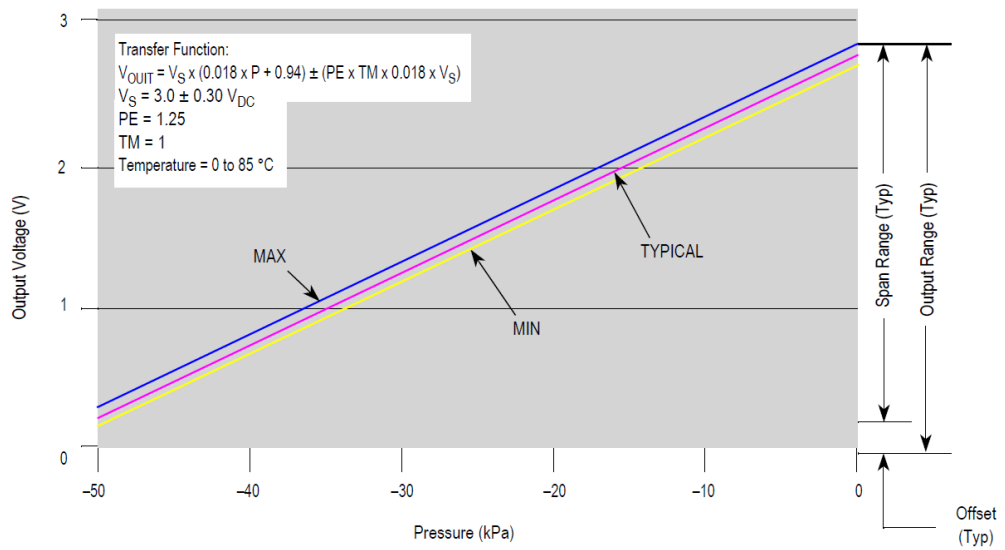
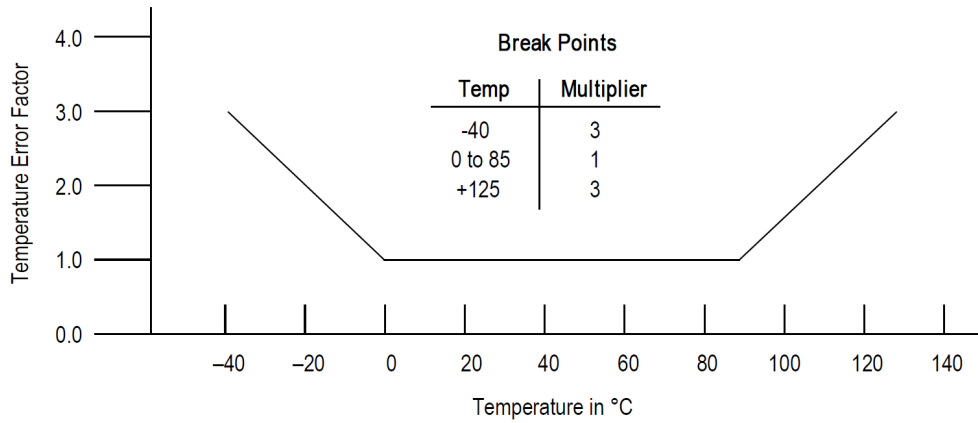

Figure 6. Transfer function

Nominal Transfer Value: $V_{OUT} = V_S \times (0.018 \times P + 0.94) \pm (\text{Pressure Error} \times \text{Temp Multi} \times 0.018 \times V_S)$
 $V_S = 3.0 \pm 0.3 \text{ V}$

Figure 7. Temperature error band



NOTE: The Temperature Multiplier is a linear response from 0 °C to -40 °C and from 85 °C to 125 °C.

Figure 8. Pressure error band

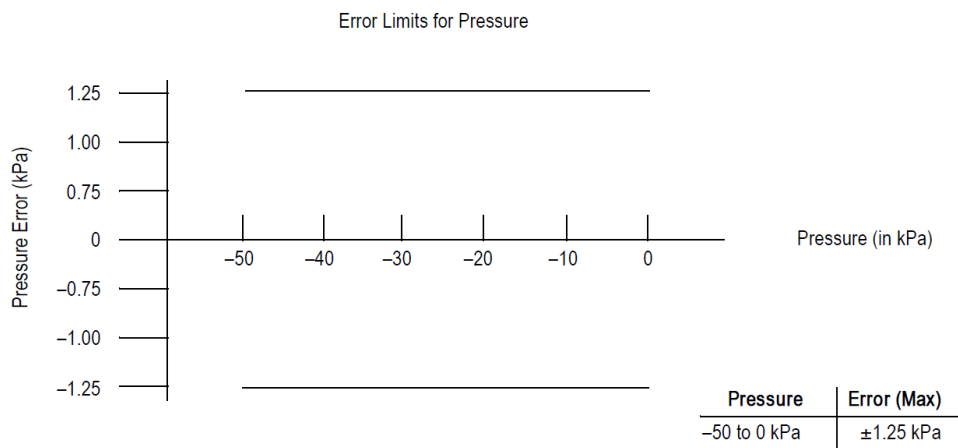

4 Package Information

4.1 Minimum recommended footprint for surface mounted applications

Surface mount board layout is a critical portion of the total design. The footprint for the semiconductor package must be the correct size to ensure proper solder connection interface between the board and the package. With the correct pad geometry, the packages will self-align when subjected to a solder reflow process. It is always recommended to fabricate boards with a solder mask layer to avoid bridging and/or shorting between solder pads, especially on tight tolerances and/or tight layouts.

Figure 9. SOP footprint

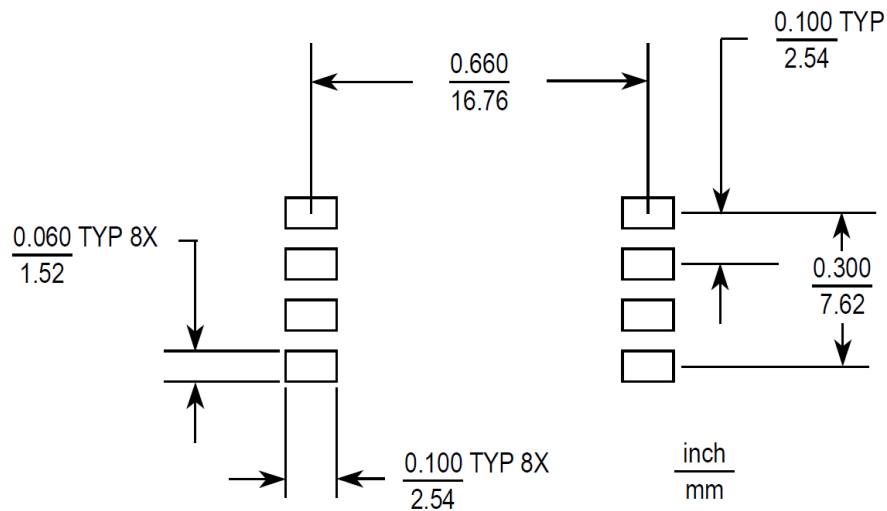

4.2 Package dimensions

Figure 10. Case 98ASB17757C, small outline package

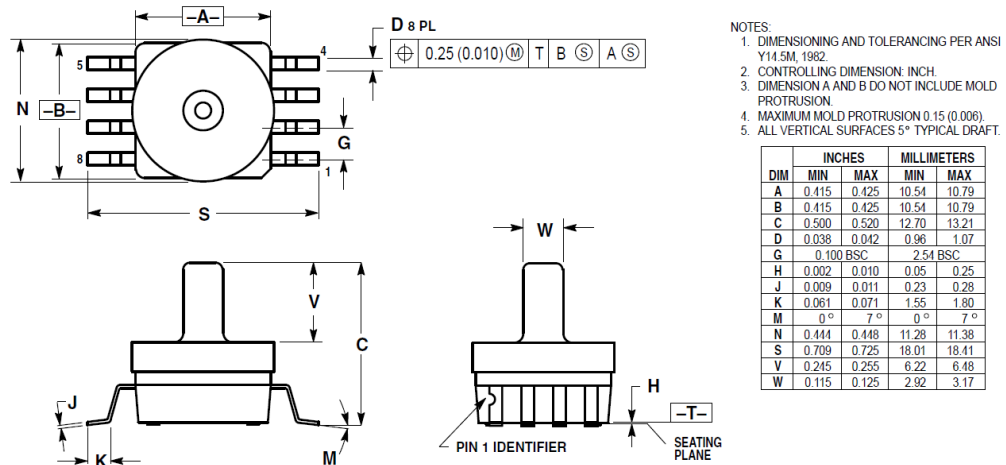

Revision history

Table 5. Document revision history

Date	Revision	Changes
14-May-2026	1	Initial release from ST, rebranded NXP document

Contents

1	General Description	2
1.1	Ordering information	2
1.2	Block diagram	2
1.3	Pinout	3
2	Mechanical and Electrical Specifications	4
2.1	Maximum ratings	4
2.2	Operating characteristics	4
3	On-chip Temperature Compensation and Calibration	6
4	Package Information	9
4.1	Minimum recommended footprint for surface mounted applications	9
4.2	Package dimensions	9
	Revision history	10

IMPORTANT NOTICE – READ CAREFULLY

STMicroelectronics NV and its subsidiaries (“ST”) reserve the right to make changes, corrections, enhancements, modifications, and improvements to ST products and/or to this document at any time without notice.

In the event of any conflict between the provisions of this document and the provisions of any contractual arrangement in force between the purchasers and ST, the provisions of such contractual arrangement shall prevail.

The purchasers should obtain the latest relevant information on ST products before placing orders. ST products are sold pursuant to ST’s terms and conditions of sale in place at the time of order acknowledgment.

The purchasers are solely responsible for the choice, selection, and use of ST products and ST assumes no liability for application assistance or the design of the purchasers’ products.

No license, express or implied, to any intellectual property right is granted by ST herein.

Resale of ST products with provisions different from the information set forth herein shall void any warranty granted by ST for such product.

If the purchasers identify an ST product that meets their functional and performance requirements but that is not designated for the purchasers’ market segment, the purchasers shall contact ST for more information.

ST and the ST logo are trademarks of ST. For additional information about ST trademarks, refer to www.st.com/trademarks. All other product or service names are the property of their respective owners.

Information in this document supersedes and replaces information previously supplied in any prior versions of this document.

© 2026 STMicroelectronics – All rights reserved