

Features

- Extendible general purpose evaluation board based on the STM32F103RET6 micro
- Multiple power supply options
- USB and mini-USB connectors
- 20-pin and 25-pin connectors exporting the STM32F GPIOs
- SiLabs CP2102 USB-RS232 bridge
- Voltage battery measurement circuitry
- Configurable LEDs and pushbuttons
- Power LED
- Reset pushbutton
- STM75 temperature sensor
- JTAG connector
- Compact size: 11.9 x 6.9 cm

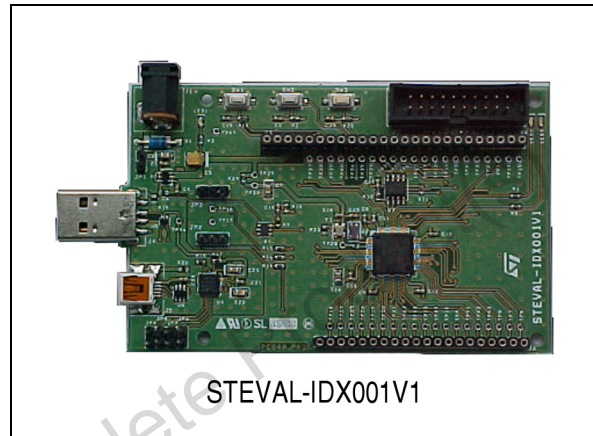

Description

The STEVAL-IDX001V1 demonstration board is based on the STM32F103RET6 micro with 512 kB of Flash and 64 kB of RAM. It has been designed to be easily extended with daughterboards that can be piled up by means of the integrated 20-pin and 25-pin connectors.

These connectors mainly export the GPIOs of the micro and other board system signals. The micro can be programmed and debugged via the JTAG and the USB connectors that are also integrated. The STEVAL-IDX001V1 demonstration board allows different power supply options.

Configurable LEDs and pushbuttons are integrated to allow user interaction at the run time. Onboard jumpers allow the configuration of the micro boot mode, the power source and the USB interface for connection with a PC. In particular, the use of the USB requires the installation of the driver of the RS-232 SiLab CP2102 bridge while the use of the mini-USB requires the installation of the STM32F USB driver available from the ST website.

1 Block diagram

Figure 1. Block diagram

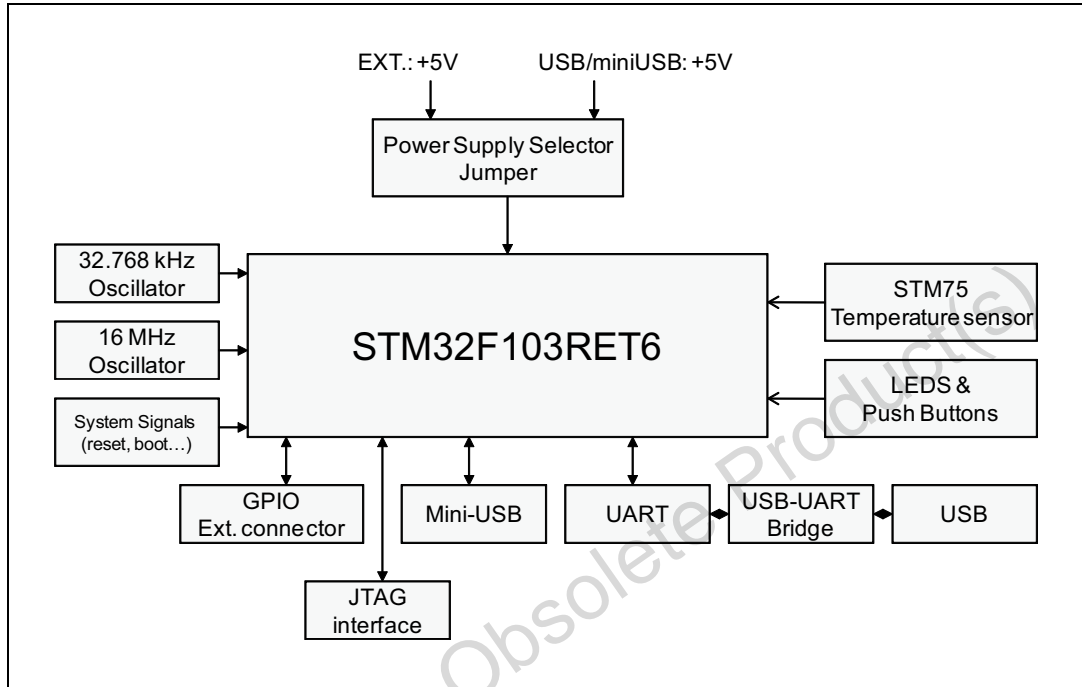

Obsolete Product(s) - Obsolete Product(s)

1.2 Main components

Figure 3. Main components

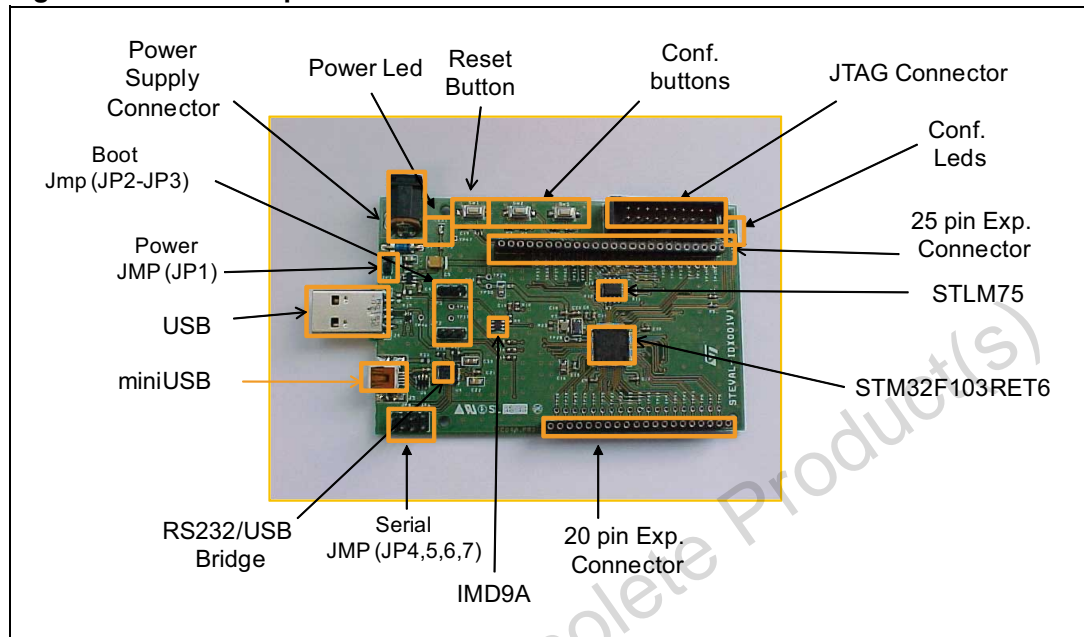

2 Revision history

Table 1. Document revision history

Date	Revision	Changes
27-Apr-2012	1	Initial release.

Obsolete Product(s) - Obsolete Product(s)

Please Read Carefully:

Information in this document is provided solely in connection with ST products. STMicroelectronics NV and its subsidiaries ("ST") reserve the right to make changes, corrections, modifications or improvements, to this document, and the products and services described herein at any time, without notice.

All ST products are sold pursuant to ST's terms and conditions of sale.

Purchasers are solely responsible for the choice, selection and use of the ST products and services described herein, and ST assumes no liability whatsoever relating to the choice, selection or use of the ST products and services described herein.

No license, express or implied, by estoppel or otherwise, to any intellectual property rights is granted under this document. If any part of this document refers to any third party products or services it shall not be deemed a license grant by ST for the use of such third party products or services, or any intellectual property contained therein or considered as a warranty covering the use in any manner whatsoever of such third party products or services or any intellectual property contained therein.

UNLESS OTHERWISE SET FORTH IN ST'S TERMS AND CONDITIONS OF SALE ST DISCLAIMS ANY EXPRESS OR IMPLIED WARRANTY WITH RESPECT TO THE USE AND/OR SALE OF ST PRODUCTS INCLUDING WITHOUT LIMITATION IMPLIED WARRANTIES OF MERCHANTABILITY, FITNESS FOR A PARTICULAR PURPOSE (AND THEIR EQUIVALENTS UNDER THE LAWS OF ANY JURISDICTION), OR INFRINGEMENT OF ANY PATENT, COPYRIGHT OR OTHER INTELLECTUAL PROPERTY RIGHT.

UNLESS EXPRESSLY APPROVED IN WRITING BY TWO AUTHORIZED ST REPRESENTATIVES, ST PRODUCTS ARE NOT RECOMMENDED, AUTHORIZED OR WARRANTED FOR USE IN MILITARY, AIR CRAFT, SPACE, LIFE SAVING, OR LIFE SUSTAINING APPLICATIONS, NOR IN PRODUCTS OR SYSTEMS WHERE FAILURE OR MALFUNCTION MAY RESULT IN PERSONAL INJURY, DEATH, OR SEVERE PROPERTY OR ENVIRONMENTAL DAMAGE. ST PRODUCTS WHICH ARE NOT SPECIFIED AS "AUTOMOTIVE GRADE" MAY ONLY BE USED IN AUTOMOTIVE APPLICATIONS AT USER'S OWN RISK.

Resale of ST products with provisions different from the statements and/or technical features set forth in this document shall immediately void any warranty granted by ST for the ST product or service described herein and shall not create or extend in any manner whatsoever, any liability of ST.

ST and the ST logo are trademarks or registered trademarks of ST in various countries.

Information in this document supersedes and replaces all information previously supplied.

The ST logo is a registered trademark of STMicroelectronics. All other names are the property of their respective owners.

© 2012 STMicroelectronics - All rights reserved

STMicroelectronics group of companies

Australia - Belgium - Brazil - Canada - China - Czech Republic - Finland - France - Germany - Hong Kong - India - Israel - Italy - Japan - Malaysia - Malta - Morocco - Philippines - Singapore - Spain - Sweden - Switzerland - United Kingdom - United States of America

www.st.com