

## 1 kW CCM totem-pole PFC using PowerGaN

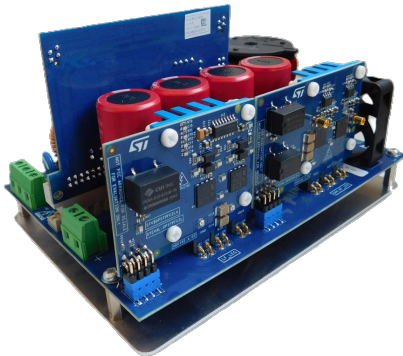

The picture shown is for illustration purpose only. Actual product may vary depending on buyer's selection and availability.

### Features

- Nearly 99% peak efficiency
- Input voltage range: 90 to 264 Vac
- Line frequency range: 47 to 63 Hz
- Maximum output power: 1 kW at 230 Vac, 500 W at 115 Vac
- Nominal output voltage: 400 Vdc
- Power factor: > 0.98 at 230 Vac, > 0.99 at 115 Vac, full load
- Total harmonic distortion (THDi): < 4% at 115 Vac, < 5% at 230 Vac, full load
- Switching frequency: 70 kHz
- Power stage based on [SGT080R70ILB](#) PowerGaN and [ST8L65N044M9](#) MDmesh M9 Power MOSFET
- Control system based on 2p2z regulators

### Description

Product summary	
1 kW CCM totem-pole PFC using PowerGaN	<a href="#">STEVAL-DPSTPFC2</a>
700 V, 60 mOhm typ., 29 A, e-mode PowerGaN transistor	<a href="#">SGT080R70ILB</a>
N-channel 650 V, 36 mOhm typ., 58 A MDmesh M9 Power MOSFET in a PowerFLAT 8x8 HV package	<a href="#">ST8L65N044M9</a>
Isolated 3 A single gate driver for Enhancement mode GaN FETs	<a href="#">STGAP2GSNCTR</a>
Galvanically isolated 4 A half-bridge dual channel gate driver	<a href="#">STGAP2DMTR</a>
Applications	<a href="#">Digital power/PFC converter - Single phase input</a>

The [STEVAL-DPSTPFC2](#) kit is a 1 kW power factor correction (PFC) converter based on bridgeless totem-pole topology, operating in continuous conduction mode (CCM) and designed to address high efficiency and power density.

The solution is based on gallium nitride (GaN) technology [SGT080R70ILB](#), and the advantage of negligible reverse recovery losses makes it ideal in this kind of applications where CCM mode is required.

The low frequency leg in this topology is realized using Si MOSFET [ST8L65N044M9](#) instead of using diodes, reducing conduction losses.

The [STEVAL-DPSTPFC2](#) kit regulates a constant output bus voltage both at 115 and 230 Vrms, reaching a peak efficiency of nearly 99%.

The control algorithm is implemented using the vertically pluggable control board, [STEVAL-DPS334C1](#).

The gate drivers used, [STGAP2GSN](#) and [STGAP2D](#) ensure reliable driving for the GaN and Si MOSFET respectively also providing galvanic isolation.

The solution is ideal for industrial digital power supplies, heat pumps, and motor control applications, demanding for high-performance AFE.

# 1 Block diagram and control system description

The PFC control algorithm is based on a cascade control with an inner current control loop executed at high frequency (cycle-by-cycle: at PWM frequency).

An outer voltage loop, executed at lower frequency (6 kHz by default), gives the amplitude of the inductor current reference needed to regulate the desired output voltage.

The sinusoidal current reference is obtained by multiplying the output of the voltage regulator by the last  $V_{ac}$  measure.

An input feedforward term is also multiplied to improve dynamic performances.

Both regulators are based on two poles-two zeros (2p2z) controllers designed in the frequency domain to obtain desired stability criteria (phase margin and crossover frequency) and discretized obtaining a linear differential equation (LDE), easy to be implemented in MCU. PID regulators are also available.

Figure 1. High level block diagram of STEVAL-DPSTPFC2

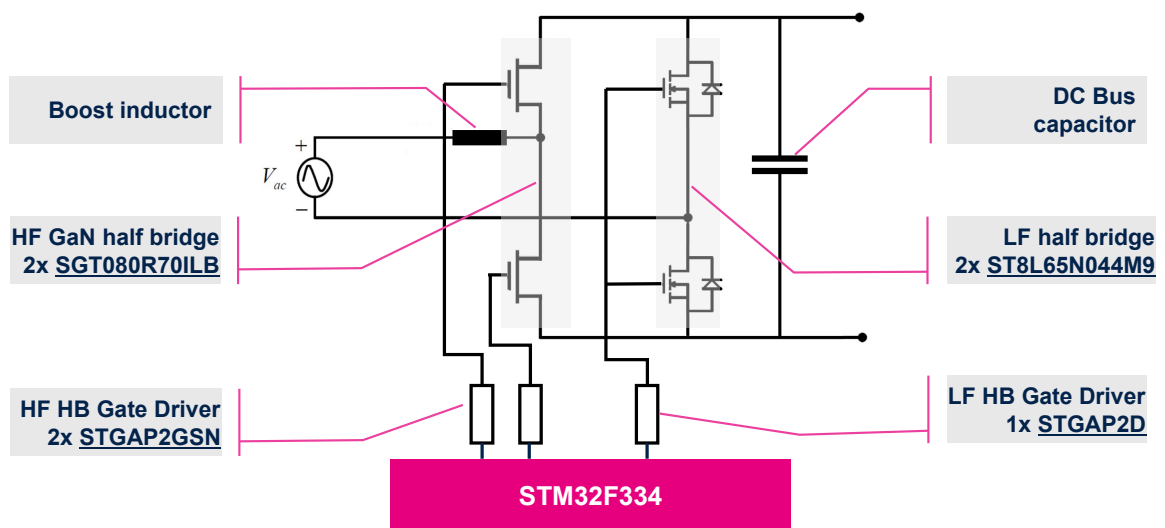
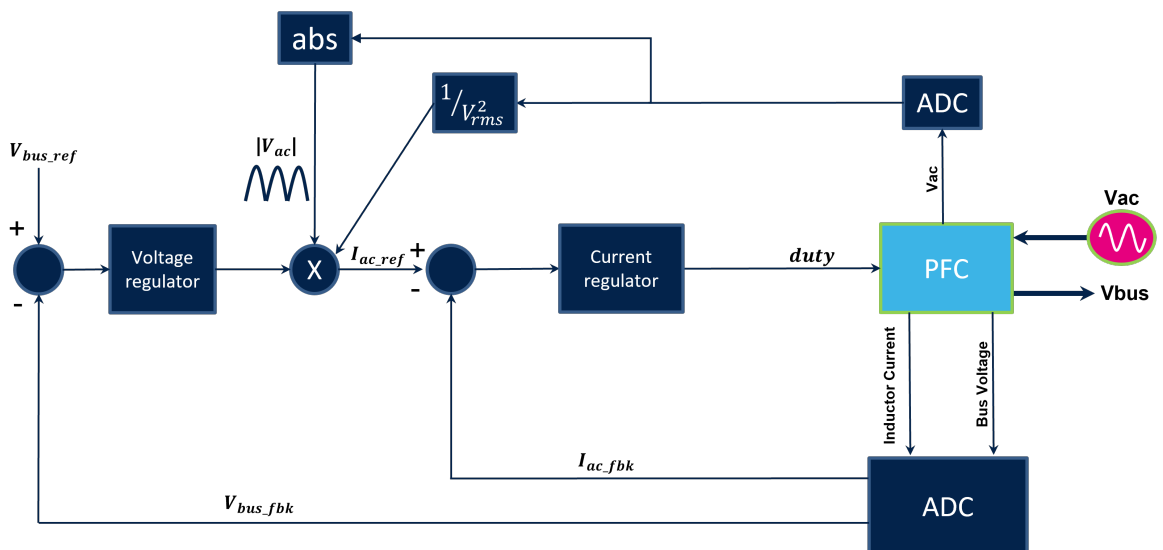

Figure 2. Control scheme block diagram



## 2 Schematic diagrams

Notice: These schematics are for illustration purpose only. Actual product may vary depending on buyer's selection and availability.

Figure 3. STEVAL-DPS334M1 - Microcontroller board - Circuit schematic (1 of 3)

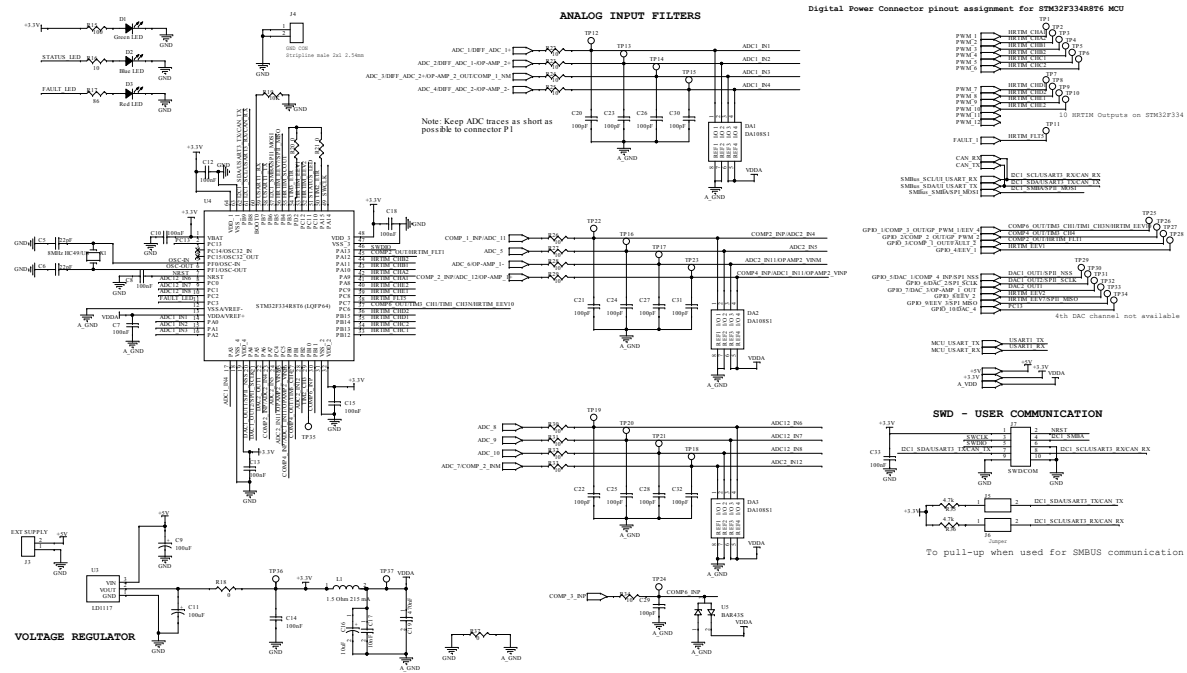

Figure 4. STEVAL-DPS334M1 - Microcontroller board - Circuit schematic (2 of 3)

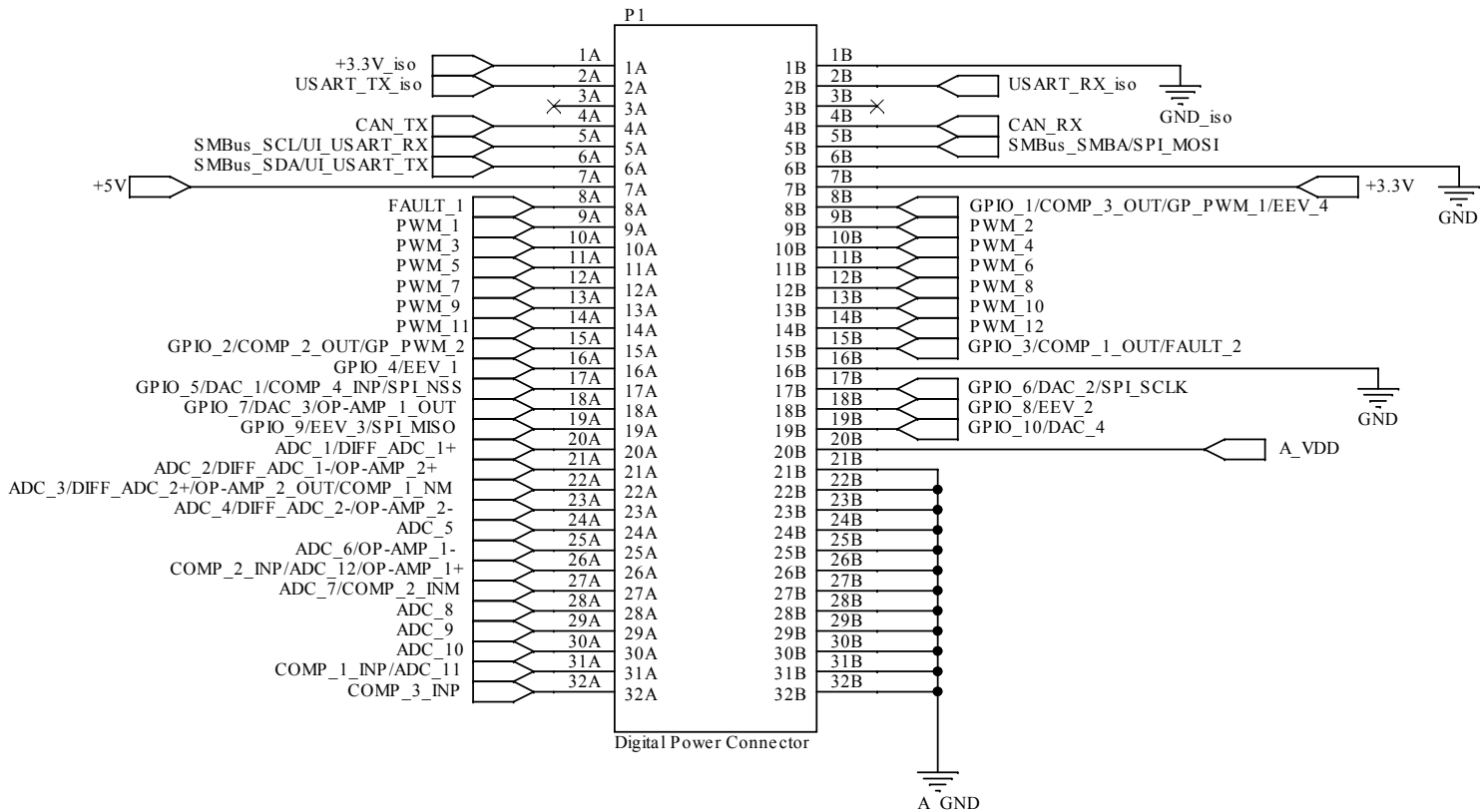

Figure 5. STEVAL-DPS334M1 - Microcontroller board - Circuit schematic (3 of 3)

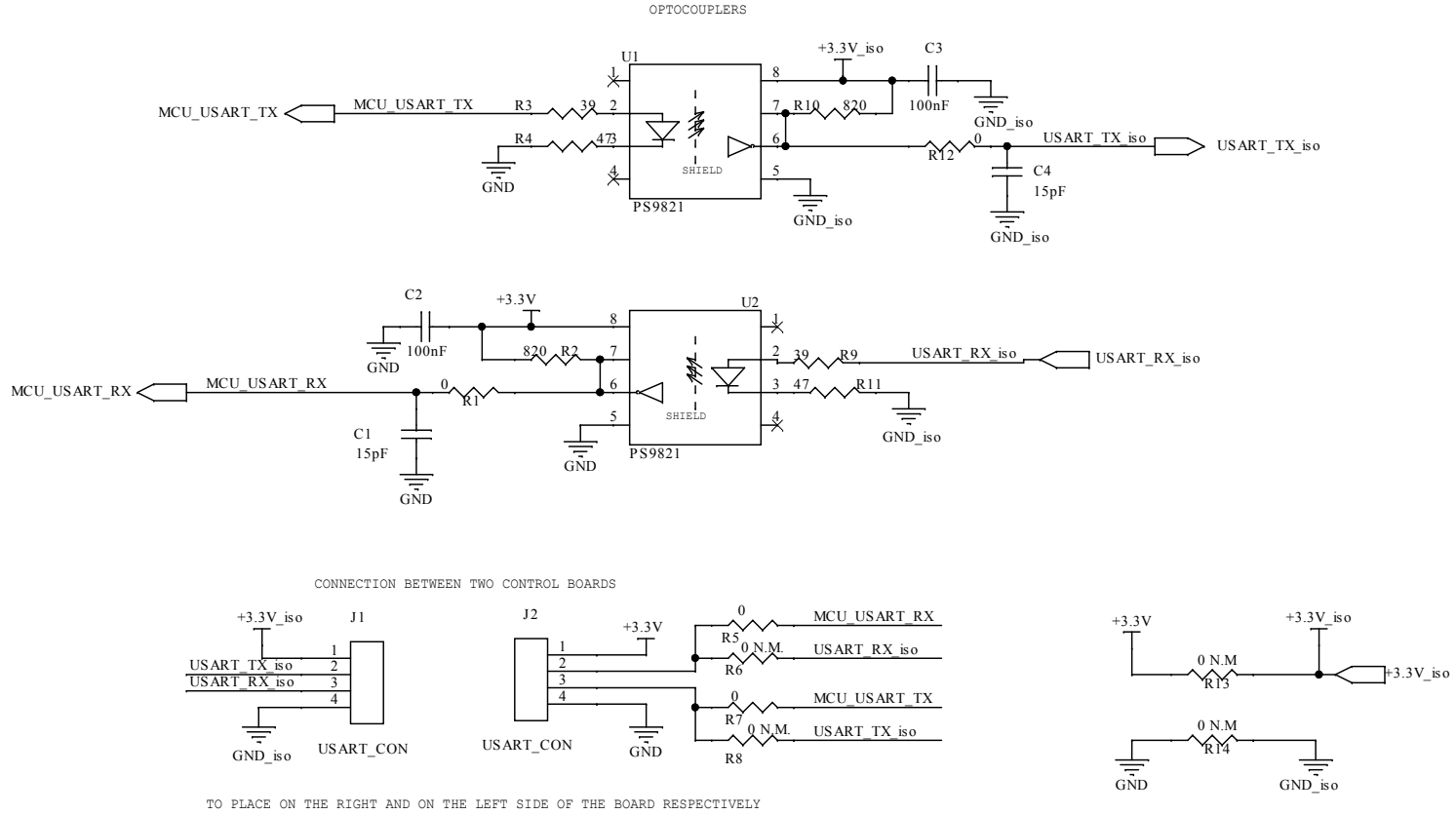
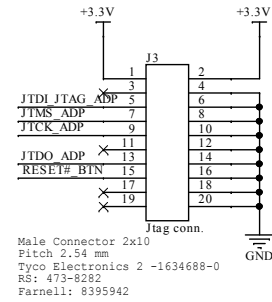
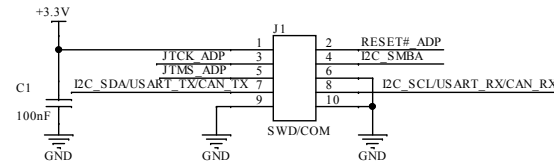

Figure 6. STEVAL-DPSADP01 - Adapter for microcontroller board - Circuit schematic

JTAG



SWD - USER COMMUNICATION



USER COMMUNICATION CONFIG

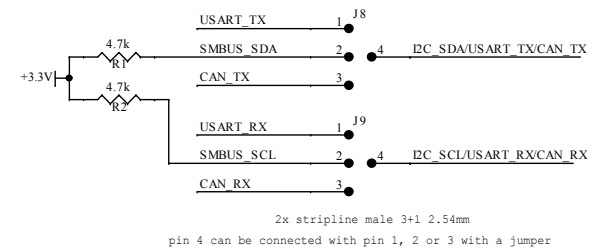

CAN

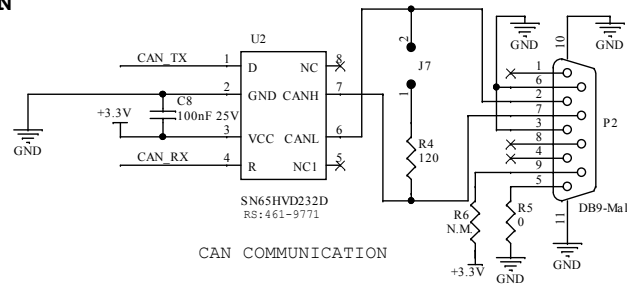

SMBUS

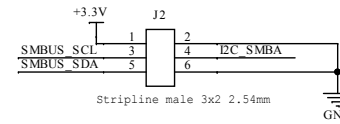

RESET BUTTON

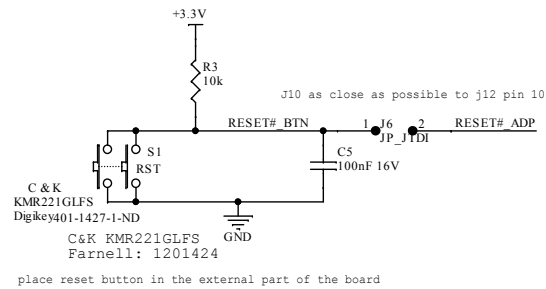

RS-232

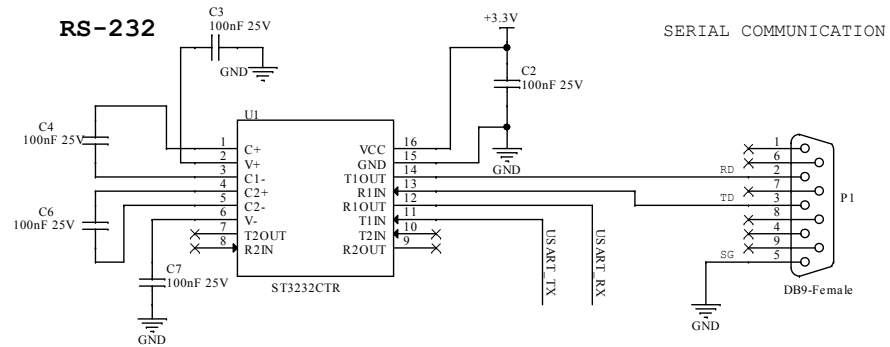
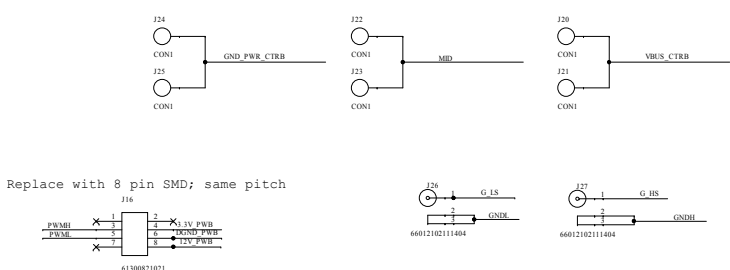
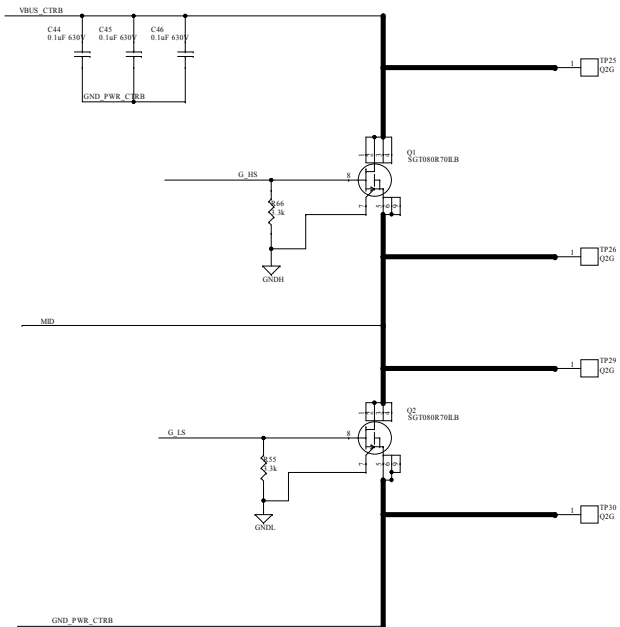
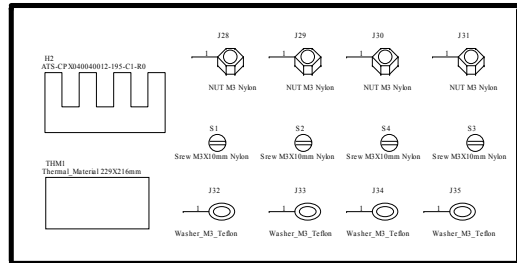

Figure 7. STEVAL-DPSTPFC2H - High frequency leg - Circuit schematic



Replace with 8 pin SMD; same pitch

HeatSink Assembly



LOW SIDE Driving

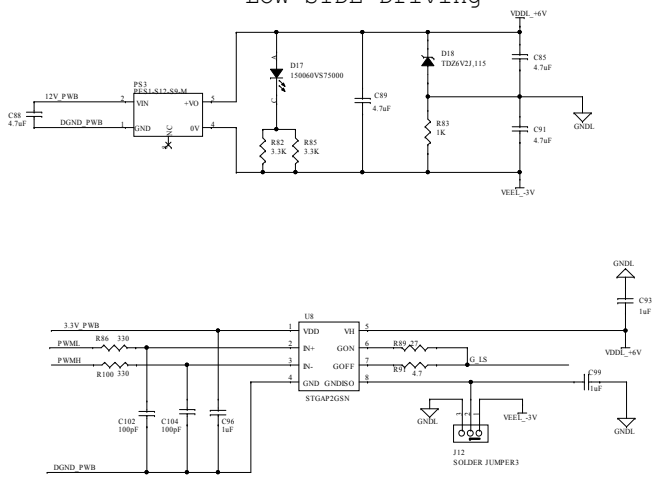

HIGH SIDE Driving

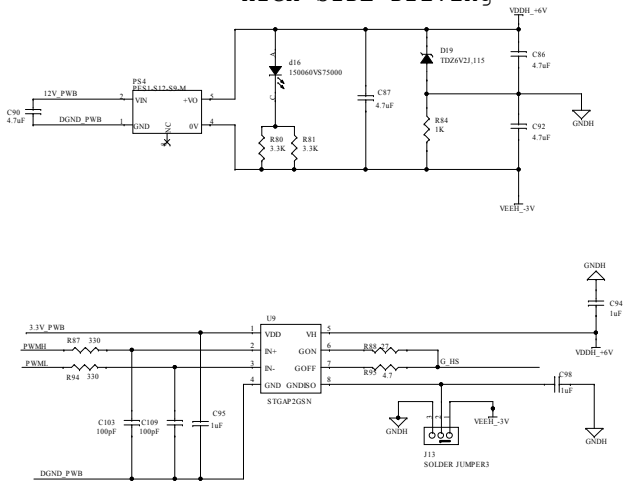



Figure 9. STEVAL-DPSTPFC2P - Power board - Circuit schematic (1 of 5)

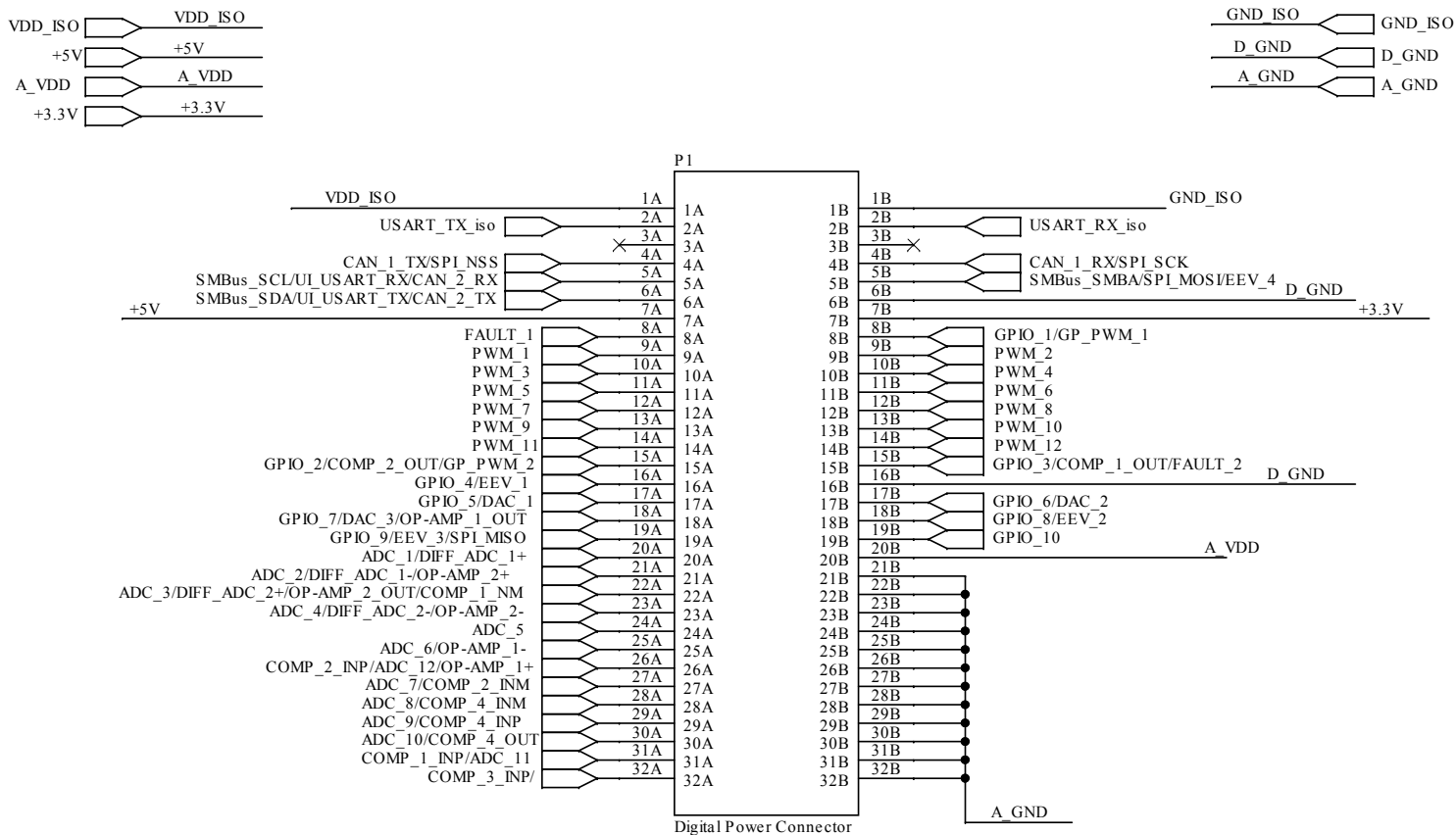

Figure 10. STEVAL-DPSTPFC2P - Power board - Circuit schematic (2 of 5)

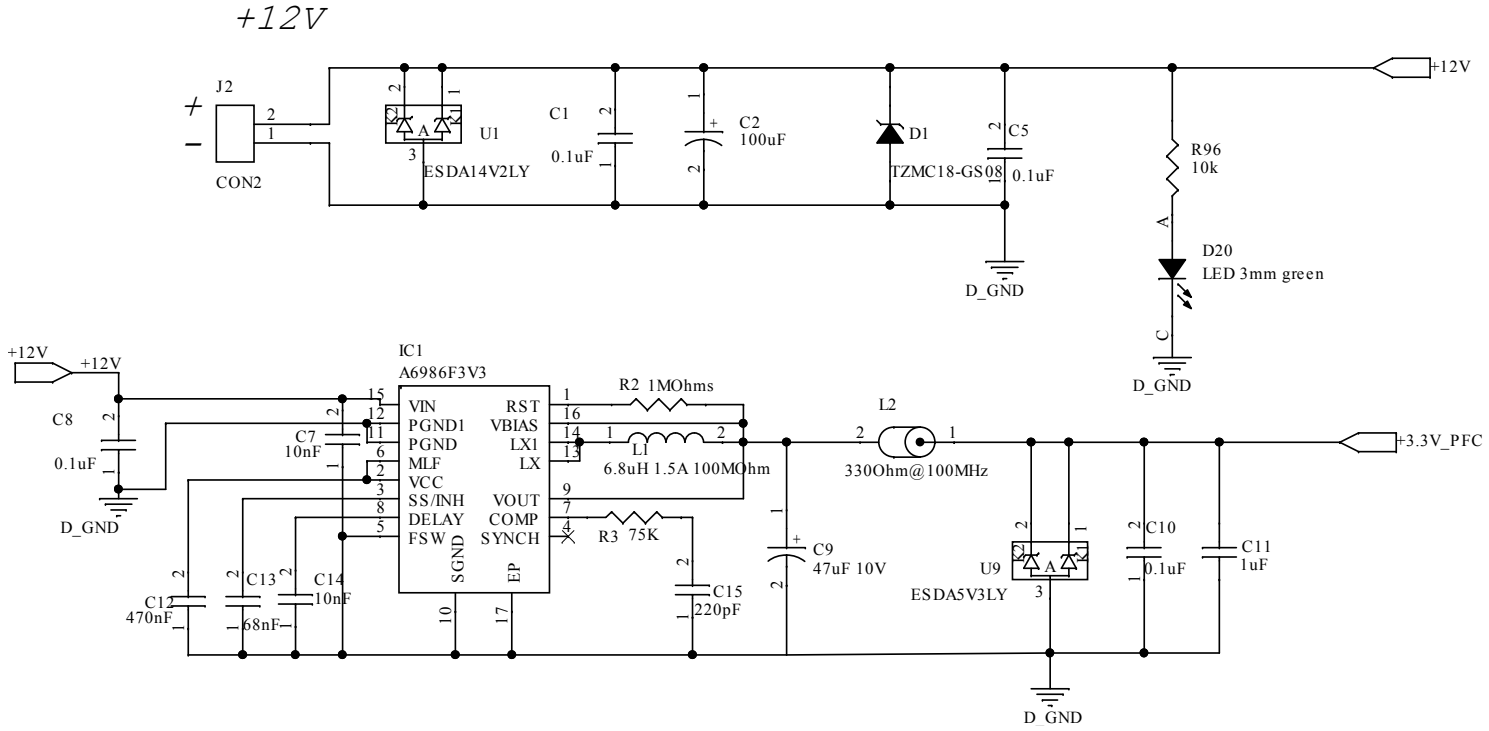

Figure 11. STEVAL-DPSTPFC2P - Power board - Circuit schematic (3 of 5)

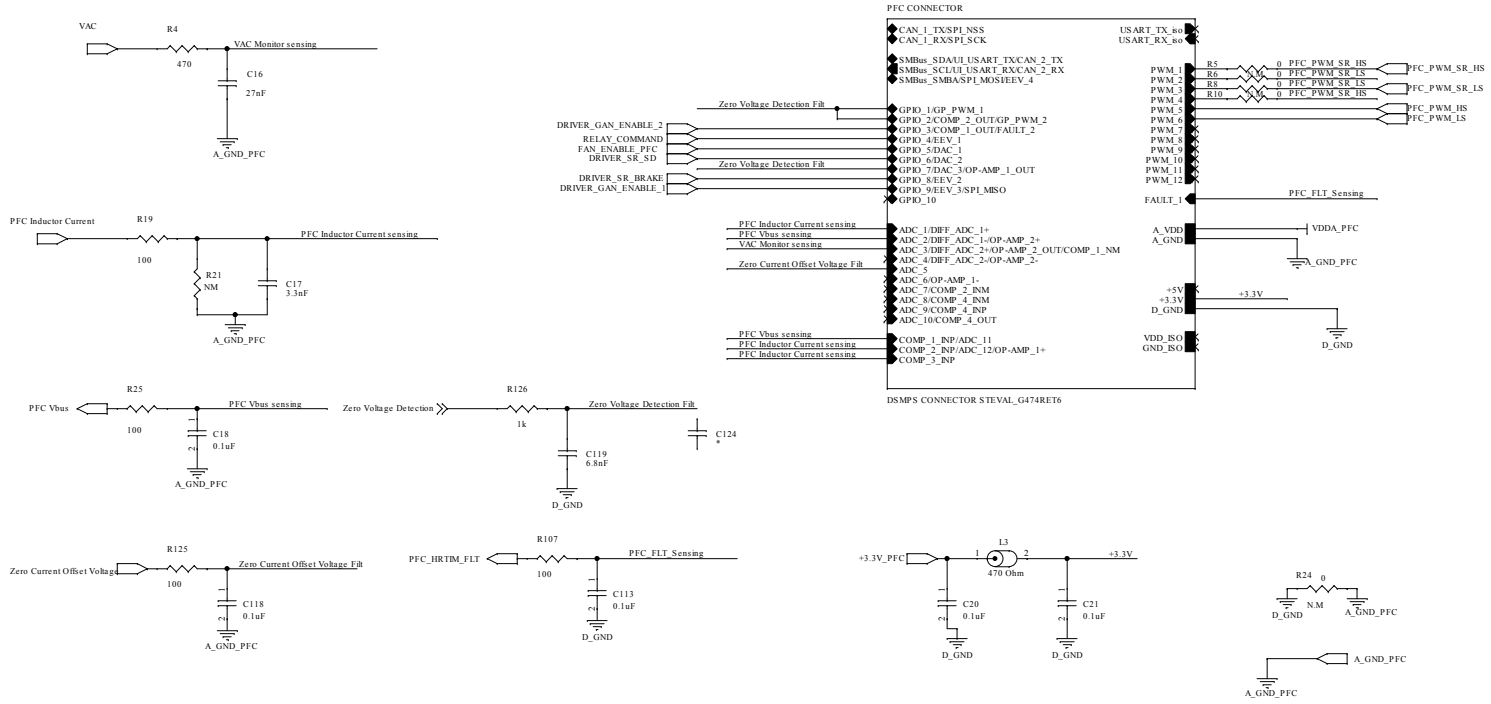

Figure 12. STEVAL-DPSTPFC2P - Power board - Circuit schematic (4 of 5)

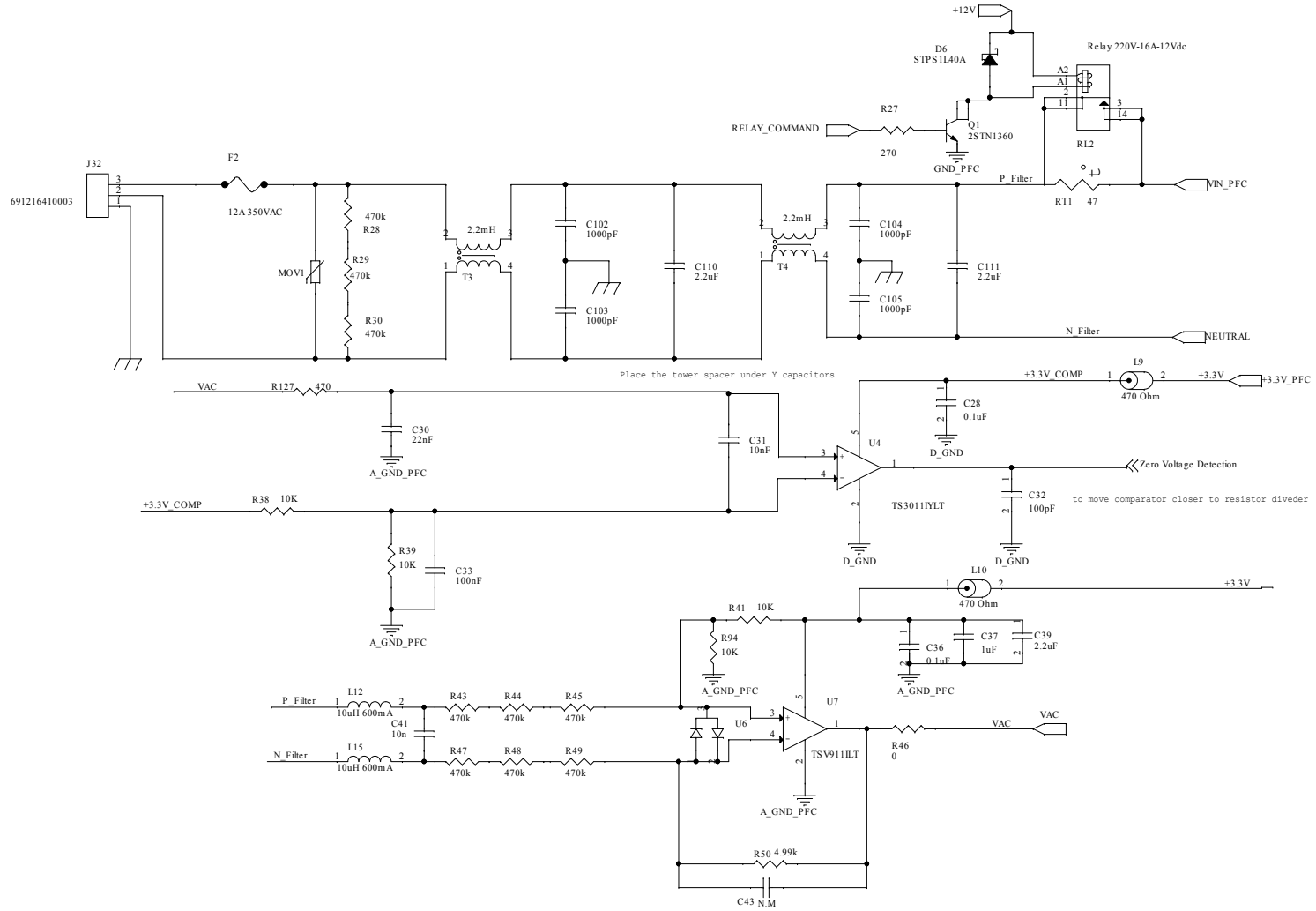
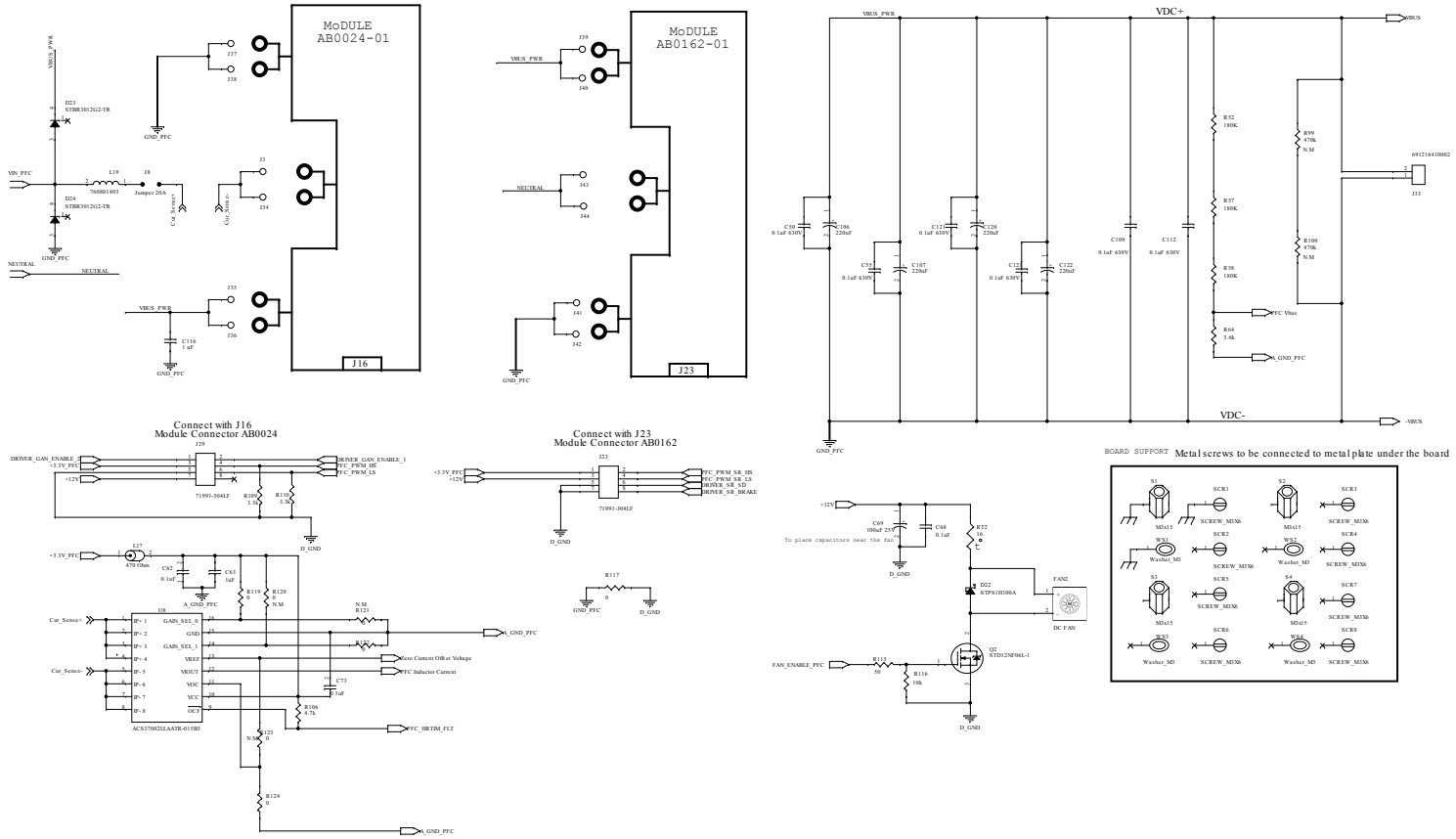

Figure 13. STEVAL-DPSTPFC2P - Power board - Circuit schematic (5 of 5)



### **3 Custom evaluation boards information**

---

*Notice: These evaluation boards are custom designed and built, in small quantities, according to specific requests from customers and are destined for evaluation and testing of ST products in a research and development setting. Please contact ST to provide your specific requests and get your custom built board(s).*

## Revision history

**Table 1. Document revision history**

Date	Revision	Changes
22-May-2026	1	Initial release.
28-May-2026	2	Updated Cover image. Minor text changes.

**IMPORTANT NOTICE – READ CAREFULLY**

STMicroelectronics NV and its subsidiaries (“ST”) reserve the right to make changes, corrections, enhancements, modifications, and improvements to ST products and/or to this document at any time without notice.

In the event of any conflict between the provisions of this document and the provisions of any contractual arrangement in force between the purchasers and ST, the provisions of such contractual arrangement shall prevail.

The purchasers should obtain the latest relevant information on ST products before placing orders. ST products are sold pursuant to ST’s terms and conditions of sale in place at the time of order acknowledgment.

The purchasers are solely responsible for the choice, selection, and use of ST products and ST assumes no liability for application assistance or the design of the purchasers’ products.

No license, express or implied, to any intellectual property right is granted by ST herein.

Resale of ST products with provisions different from the information set forth herein shall void any warranty granted by ST for such product.

If the purchasers identify an ST product that meets their functional and performance requirements but that is not designated for the purchasers’ market segment, the purchasers shall contact ST for more information.

ST and the ST logo are trademarks of ST. For additional information about ST trademarks, refer to [www.st.com/trademarks](http://www.st.com/trademarks). All other product or service names are the property of their respective owners.

Information in this document supersedes and replaces information previously supplied in any prior versions of this document.

© 2026 STMicroelectronics – All rights reserved