



life.augmented

PROTECTION & FILTERS Building Safety and Security

Video surveillance system

place for QR code



PROTECTION & FILTERS BUSINESS UNIT





Building Safety and Security overview

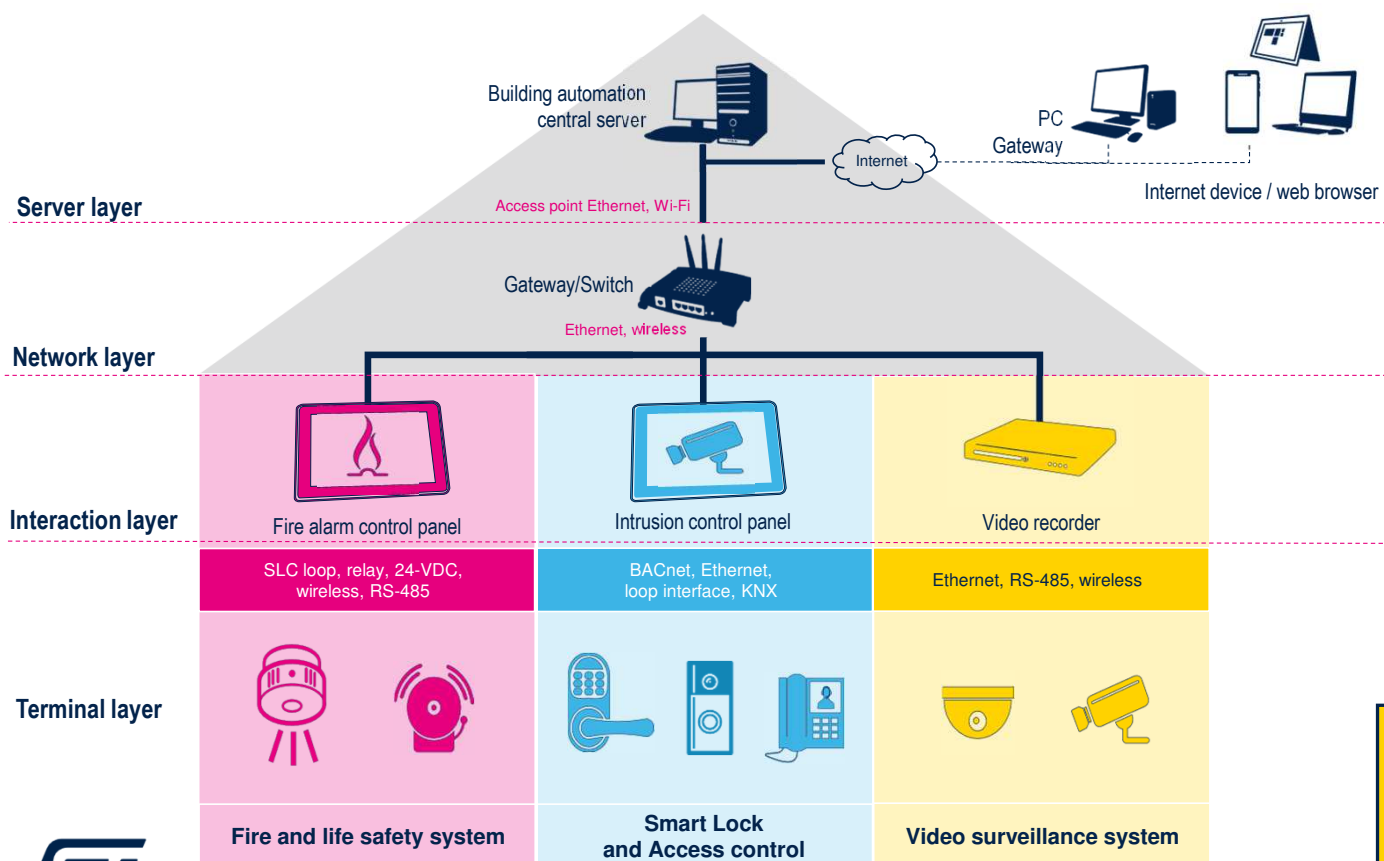

Key applications:

- **Fire and life safety system**
 - Smoke & heat detector
 - Gas and flame detector
 - Digital alarm communicator
 - Remote annunciator
 - Voice & audio amplifier
- **Smart Lock and Access**
 - Smart lock
 - Intrusion HMI
 - Video doorbell
 - Fingerprint / 3D face / Iris recognition
- **Video surveillance system**
 - NVR/DVR
 - IP Network camera
 - Analog video surveillance systems

Blue book focus



Find out more at www.st.com



Protection & Filters' solutions for Video surveillance system

RF Antennas
ESDZX168B-1BF4

USB-C (integrated solution)

Vbus and CC lines	TCPP01-M12
-------------------	----------------------------

USB 3.x type A

Vbus	ESDA7P120-1U1M
Data SSRx / SSTx	HSP053-4M5 ECMF4-40A100N10
Data D+ / D-	USBLC6-2SC6 HSP053-4M5 ECMF2-40A100N6

POE
SMA6J series SM15T series

Power supply
SM15T series SMA6J series

Charging connector Battery (V _{BUS} ; V _{BATT})
ESDAXP series SM6F series SMA6J series

Camera / Display

Data / Clock	HSP053-4M5 ECMF4-40A100N10 (differential lines) EMIF08-LCD04M16 (parallel link)
I2C	ESDZV5-1BF4 USBLC6-2SC6

SIM card

CLK / D+	ESDZL5-1F4 ESDZV5-1BF4 EMIF03-SIM02M8
SWP	ESDAXLC5-1U2*

Buttons/ Switches

ESDZL5-1F4 ESDZV5-1BF4 EMIF01-1007AF4 (*)

Speaker

ESDZV5H-1BU2

SD card

EMIF06-MSD02N16 EMIF06-HSD03F3

Microphone

ESDZV5-1BF4

eSATA

HSP053-4M5

Ethernet

HSP053-4M5

RS-485 / RS-232

ESDA14V2BP6

HDMI

Control lines	HDMI2C4-5F2 (source) HDMI2C2-5F2 (sink) ESDALC6V1-5P6
---------------	---

TMDS	HSP053-4M5 ECMF4-40A100N10
------	---

Display port

AUX	USBLC6-2SC6 DPHDMI01-5M12 (*)
-----	--

Main links	HSP053-4M5 ECMF4-40A100N10
------------	---

HPD / PWR	ESDAP series
-----------	------------------------------



**under development ; (*) Contact our sales office*

**Antennas are ESD protected according to IEC 61000-4-2 level 4
Very low harmonics generation ensures no disturbance in application**

Wi-Fi antenna needs	Key product parameters	ST solutions
RF power = 23 dBm ($V_{PEAK} = 4.5\text{ V}$ with $50\ \Omega$ load)	$V_{RM} \geq 16\text{ V}$	<u>ESDZX168B-1BF4</u>
Alternative signal	Bidirectional device	
f = 2.4 GHz f = 5.0 GHz	Extra low capacitance = 0.12 pF Bandwidth >40 GHz	
Very low harmonic <41dBm @ 23 dBm	H3 = -61 dBm @ 23 dBm, f = 2.4 GHz H3 = -62 dBm @ 23 dBm, f = 5.0 GHz	
Needs for Bluetooth antenna	Product key parameters	ST solutions
RF power = 20 dBm ($V_{PEAK} = 3.2\text{ V}$ with $50\ \Omega$ load)	$V_{RM} = 16\text{ V}$	<u>ESDZX168B-1BF4</u>
Alternative signal	Bidirectional device	
f = 2.4 GHz	Extra low capacitance: 0.12 pF - Bandwidth >40 GHz	
Very low harmonic <41dBm @ 20 dBm	H3 = -70 dBm @ 20 dBm, f = 2.4 GHz	

Socket specifics

ST product parameter impact

ST recommended product

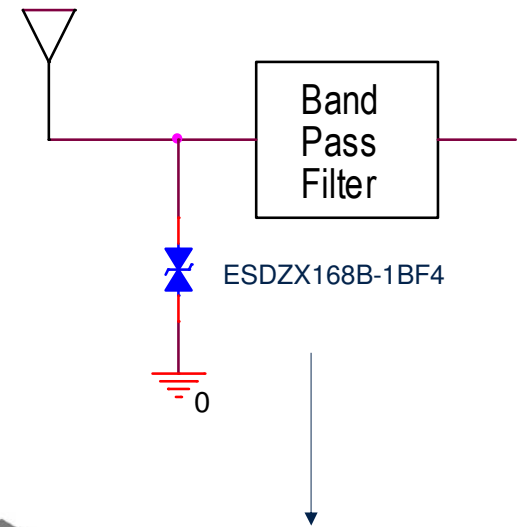

Block diagram or schematic



Antennas

GSM / DCS / PCS (2G) / 3G / 4G / 5G

All sockets are ESD protected according to IEC 61000-4-2 level 4

Needs for GSM / DCS / PCS (2G)	Product key parameters	ST solutions
RF power = 34 dBm ($V_{PEAK} = 16$ V with 50 Ω load)	$V_{RM} = 16$ V	<u>ESDZX168B-1BF4</u>
Alternative signal	Bidirectional device	
$f < 1.9$ GHz	Extra low capacitance (≤ 0.3 pF)	
Needs for WCDMA (3G)	Product key parameters	ST solutions
RFpower max = 27 dBm ($V_{PEAK} = 7$ V on 50 Ω load)	$V_{RM} \geq 7$ V	<u>ESDZX168B-1BF4</u>
Alternative signal	Bidirectional device	
$f = 900$ MHz or 2.1 GHz	Extra low capacitance (≤ 0.3 pF)	
Very low harmonic < -41 dBm at 27 dBm	H3 = -48 dB at 27 dBm power at $f = 900$ MHz H3 = -47 dBm at 27 dBm power at $f = 1.8$ GHz	
Needs for LTE (4G)	Product key parameters	ST solutions
RF power max = 27 dBm ($V_{PEAK} = 7$ V (50 Ω load))	$V_{RM} \geq 7$ V	<u>ESDZX168B-1BF4</u>
Alternative signal	Bidirectional device	
$f < 2.7$ GHz	Extra low capacitance (≤ 0.3 pF)	
Very low harmonic < -41 dBm at 27 dBm	H3 = -48 dB at 27 dBm power at $f = 900$ MHz H3 = -47 dBm at 27 dBm power at $f = 1.8$ GHz	
Needs for 5G	Product key parameters	ST solutions
RFpower max = 27 dBm ($V_{PEAK} = 7$ V on 50 Ω load)	$V_{RM} \geq 7$ V	<u>ESDZX168B-1BF4</u>
Alternative signal	Bidirectional device	
$f < 5$ GHz	Extra low capacitance (≤ 0.3 pF)	
Very low harmonic < -41 dBm at 27 dBm	H3 = -48 dB at 27 dBm power at $f = 900$ MHz H3 = -47 dBm at 27 dBm power at $f = 1.8$ GHz	





Antennas GNSS

Antennas are ESD protected according to IEC 61000-4-2 level 4
 Very low harmonics ensure no disturbance in application – Low Insertion losses

Needs for GNSS antenna	Product key parameters	ST solutions
Voltage \leq 3.6V	$V_{RM} = 16$ V	<u>ESDZX168B-1BF4</u>
Alternative signal	Bidirectional device	
$f = 1.5$ GHz	Extra low capacitance: 0.12 pF - Bandwidth >40 GHz	
IEC 61000-4-2 level 4 8kV contact / 15 kV air	Contact discharge: 12 kV Air discharge: 30 kV	

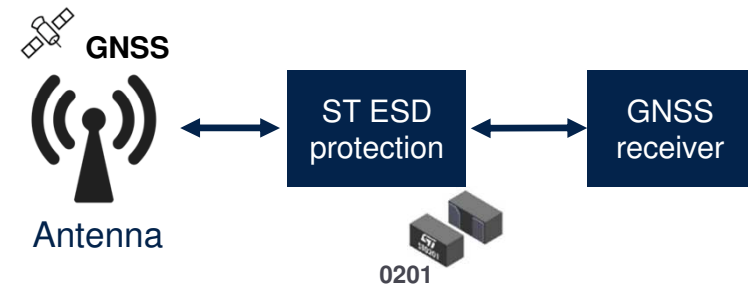

USB 2.0 type A

Complete solution portfolio for USB granting flexibility in design
All sockets are ESD protected according to IEC 61000-4-2 level 4

USB type A/B/μB

USB2.0 (D+/D-) needs	Product key parameters	ST solutions
Voltage ≤ 3.0 V	$V_{RM} = 5.25$ V	USBLC6-2SC6 (dual lines) HSP053-4M5 (pitch 500μm) ECMF2-40A100N6
Positive signal	Unidirectional	
Data rate: 480 Mbps Maximum equivalent frequency 240 MHz	Bandwidth : 3 GHz USBLC6-2SC6 Bandwidth : 18 GHz HSP053-4M5	
Avoid Wi-Fi antenna desense (2.4/5 GHz)	CMF rejection ≥ -15 dB (2.4 to 6.5 GHz)	
IEC 61000-4-2 level 4 8 kV contact/15 kV air	Contact discharge: ≥ 8 kV Air discharge: ≥ 15 kV	

USB2.0 (Vbus) needs	Product key parameters	ST solutions
Voltage ≤ 5.5 V	$V_{RM} = 5.5$ V	ESDA7P120-1U1M
Positive signal	Unidirectional	
Need to withstand 8/20 μs surge (IEC 61000-4-5)	I_{PP} up to 120 A	
IEC 61000-4-2 level 4 8 kV contact/15 kV air	Contact discharge: >30 kV Air discharge: >30 kV	

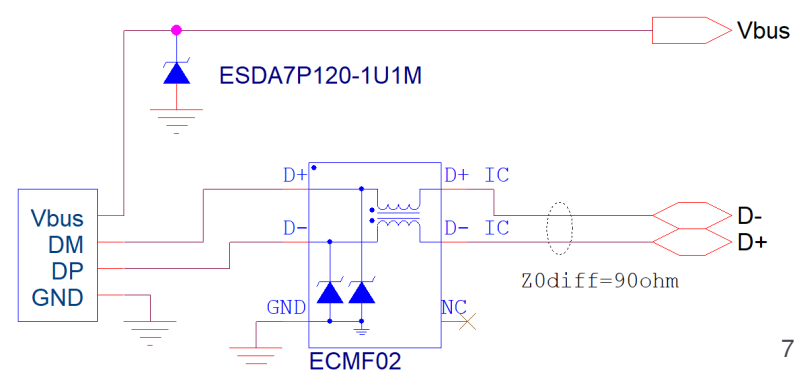
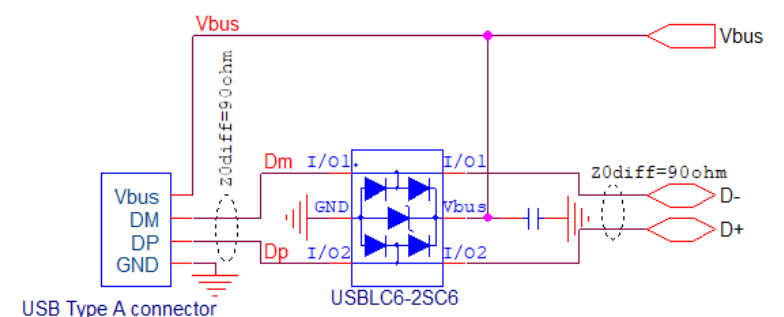



USB4 & USB 3.x / USB-C complete portfolio offer

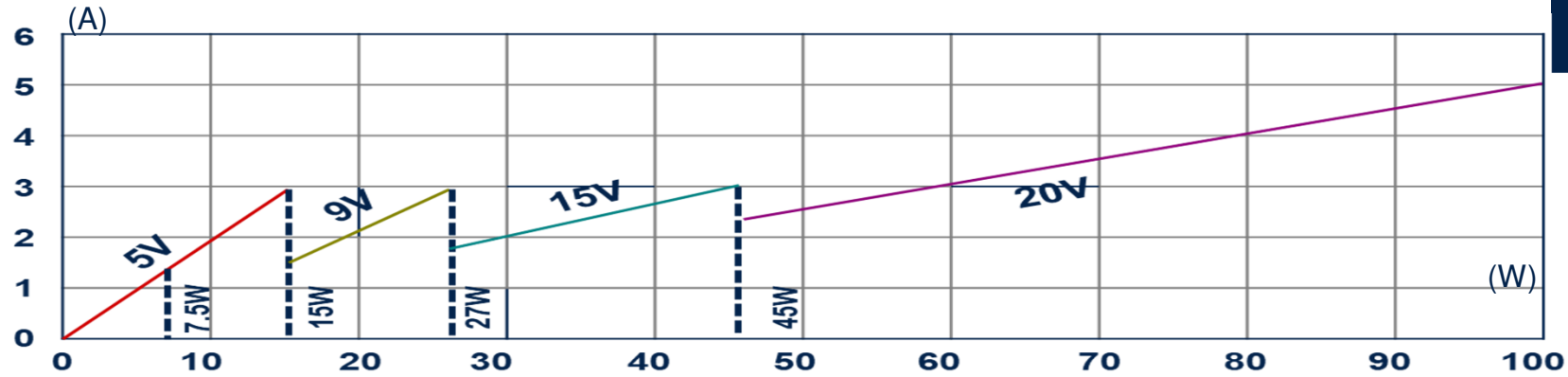

Role Type	Application STM32 based	Pins	5V – 15 W	9V – 27 W	15 V – 45 W	20 V – 100 W
All	With or without STM32	D+/D-	ASIP = ESD + CMF: ECMF2-40A100N6 // standalone ESD: USBLC6-2SC6			
		SSRx / SSTx	ASIP = ESD + CMF: ECMF4-40A100N10 // standalone ESD: HSP053-4M5			
		CC1 / CC2	ESDZV5-1BF4	<i>ESD141-1BU2*</i>	<i>ESDZ161-1BF4*</i>	ESDALC20-1BF4
		SBU1 / SBU2	ESDA6V1L	ESDA14V2L	ESDA25L	ESDA25L
		Vbus	ESDA7P60-1U1M ESDA7P120-1U1M ESDA8P30-1T2 SMAJ6.0A-TR	ESDA13P70-1U1M SMAJ12A-TR	<i>ESDZ161-1BF4*</i> SMAJ18A-TR	ESDA25P35-1U1M SMAJ24A-TR
Sink	YES	TCPP01-M12				
Source	YES	TCPP02-M18				
DRP	YES	TCPP03-M20				

TCPP series is compliant with USB Power Delivery Standard Power Range up to 100 W (5, 9, 15, 20V / 5 A)

**product under development*

USB Power Delivery Power management

Compatible and reliable up to 100 W (TCPP0 series)
Compliant with USB PD 3.2/PPS; USB-IF certification available.

Needs for USB PD management ⁰	Product key parameters	ST solutions
Compliance with USB PD 3.2 specification	USB-IF certification available TCPP01 for Sink → USB-IF-TID: 5205 TCPP02 for source → USB-IF-TID: 7884 TCPP03 for DRP → USB-IF-TID: 6408	<p><u>TCPP01-M12</u></p> <p><u>TCPP02-M18</u></p> <p><u>TCPP03-M20</u></p> <p><u>TCPP series</u></p>
Fast charging	Compliant with USB PD 3.1 including PPS up to 20 V, -5 A	
Compatible with all chargers from the market	Vcc = 24 V for TCPP0x	
Able to survive current or voltage surges and short-circuit with Vbus	Overcurrent and overvoltage protection on VBUS, CC lines VThreshold = 6 V on CC lines	
Cost effectiveness	Companion chip of STM32 with UCPD Reuse the STM32 of the application	
Use of low-cost MOSFET	Integrated VBUS load switch gate driver for external N-MOSFET	
IEC 61000-4-2 level 4 (8 kV contact/15 kV air)	Contact discharge: ≥8 kV Air discharge: ≥15 kV	

Expansion boards available

X-NUCLEO-SNK1M1

X-NUCLEO-SRC1M1

X-NUCLEO-DRP1M1

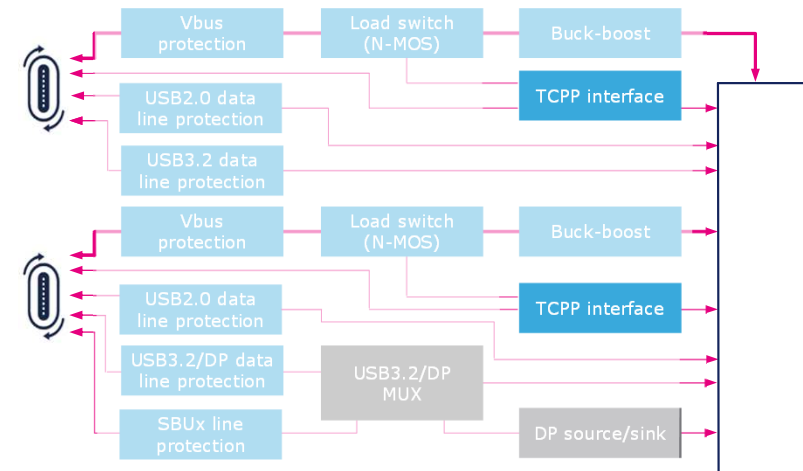



USB Power Delivery Vbus

ESD and EOS protections in CSP, QFN, and SMD packages

Needs for Vbus input	Product key parameters	ST solutions
V _{max} = 5.5 V	V _{RM} = 5.5 V	ESDA5-1F4
DC signal	Bidirectional is also compatible	
IEC 61000-4-5	Surge capability: 11 A 8/20 μs	
V _{max} = 5.5 V	V _{RM} = 6.3 V	<u>ESDA8P30-1T2</u>
DC signal	Unidirectional	
IEC 61000-4-5	Surge capability: 30 A 8/20 μs	
V _{max} = 20 V (Power Delivery)	V _{RM} = 20 V	<u>ESDALC20-1BF4</u>
DC signal	Bidirectional is also compatible	
IEC 61000-4-5	Surge capability: 2.4 A 8/20 μs	
V _{max} = 20 V (Power Delivery)	V _{RM} = 22 V	<u>ESDA25P35-1U1M</u>
DC signal	Unidirectional	
IEC 61000-4-5	Surge capability: 35 A 8/20 μs	
V _{max} = 28, 36, or 48 V +15% (EPR)	V _{RM} = 30, 40, 58 V	<u>SMAJ</u>
DC signal	Unidirectional	
IEC 61000-4-5	8/20 μs surge capability: 36, 27, 19 A	

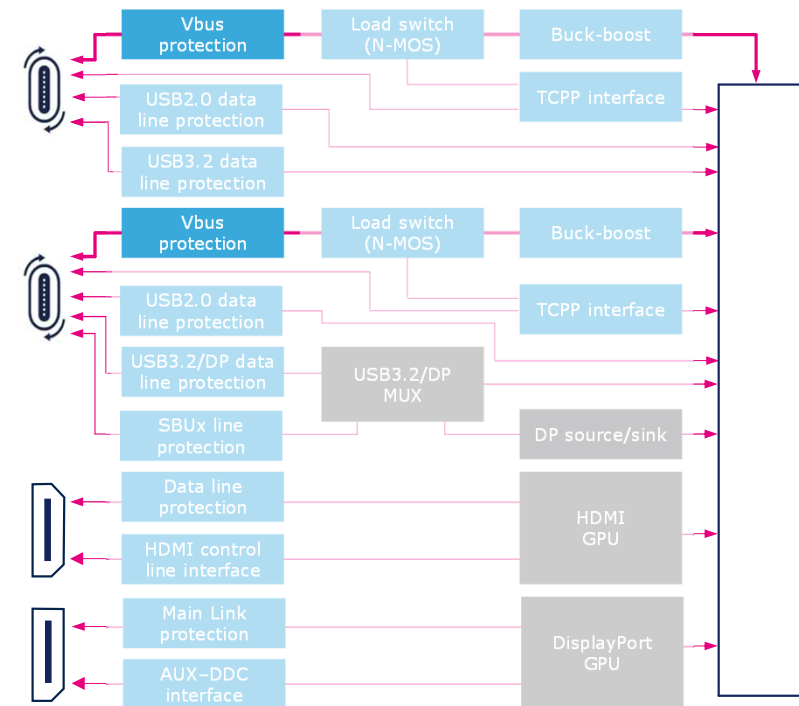

HDMI2.x TMDS/FRL lines

Standalone ESD protection or integrated solution with both ESD protection and common mode noise filter in same package

TMDS needs	Product key parameters	ST solutions
Voltage ≤ 3.3 V	$V_{RM} \geq 5$ V	HSP053-4M5 (pitch 500 μ m) ECMF4-40A100N10
Positive signal	Unidirectional	
Data rate: 18 Gbps (HDMI 2.0) Eye diagram compliancy	Bandwidth : 18 GHz Compliant with eye diagram	
Avoid Wifi antenna desense (2.4GHz / 5GHz)	CMF Rejection ≥ -15 dB (2.4 GHz to 6.5 GHz)	
IEC 61000-4-2 level 4 8 kV contact / 15 kV air	Contact discharge: ≥ 8 kV Air discharge: ≥ 15 kV	

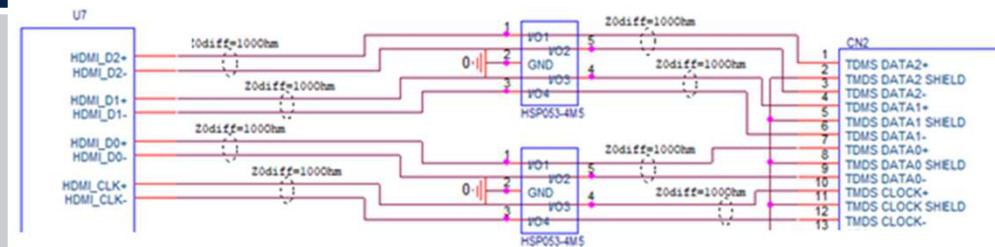

Integrated solutions for source and sink applications Dynamic pull-up against long or poor-quality HDMI cable drive

Control lines (integrated smart solutions)	Product key parameters	ST solutions
Voltage ≤ 5.0 V Level shifter from video chipset voltage to HDMI voltages	HDMI chipset voltage compatibility from 1.8 V to 5 V	<u>HDMI2C1-6C1</u> (source) <u>HDMI2C4-5F2</u> (source-HDMI 2.x) <u>HDMI2C2-5F2</u> (sink-HDMI 2.x)
Positive signal	Unidirectional	
Data rate: 3.4 Mbps	Bandwidth > 400 MHz	
Capability to drive long cable	DDC bus with dynamic pull-up Buffer for signal reshaping	
Glitch filter in HDMI2C4-5F2	For HDMI2.x clock stretching operation	
IEC 61000-4-2 level 4 (8 kV contact/15 kV air)	Contact discharge: ≥8 kV Air discharge: ≥15 kV	
Control lines (ESD protection)	Product key parameters	ST solutions
Voltage ≤ 5.0 V	$V_{RM} = 5 V$	<u>ESDALC6V1-5P6</u>
Positive signal	Unidirectional	
Data rate: 3.4 Mbps	Bandwidth > 400 MHz	
IEC 61000-4-2 level 4 (8 kV contact/15 kV air)	Contact discharge: ≥8 kV Air discharge: ≥15 kV	

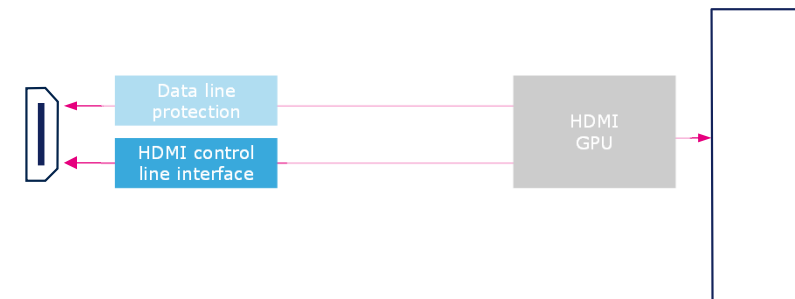

DisplayPort++ Main Link

Stand alone ESD protection or integrated solution with both ESD protection and common mode noise filter in same package

TMDS needs (integrated smart solutions)	Product key parameters	ST solutions
Voltage ≤ 3.3 V	$V_{RM} \geq 5$ V	HSP053-4M5 (QFN-5L pitch: 500 μ m)
Positive signal	Unidirectional	
Data rate: 18 Gbps (HDMI 2.0) Eye diagram compliancy	Compliant with eye diagram	ECMF4-40A100N10 (QFN-10L pitch 400 μ m)
Avoid Wi-Fi antenna disturbance (2.4/5 GHz)	CMF rejection ≥ -15 dB (2.4 to 6.5 GHz)	
IEC 61000-4-2 level 4 (8 kV contact/15 kV air)	Contact discharge: ≥ 8 kV Air discharge: ≥ 15 kV	

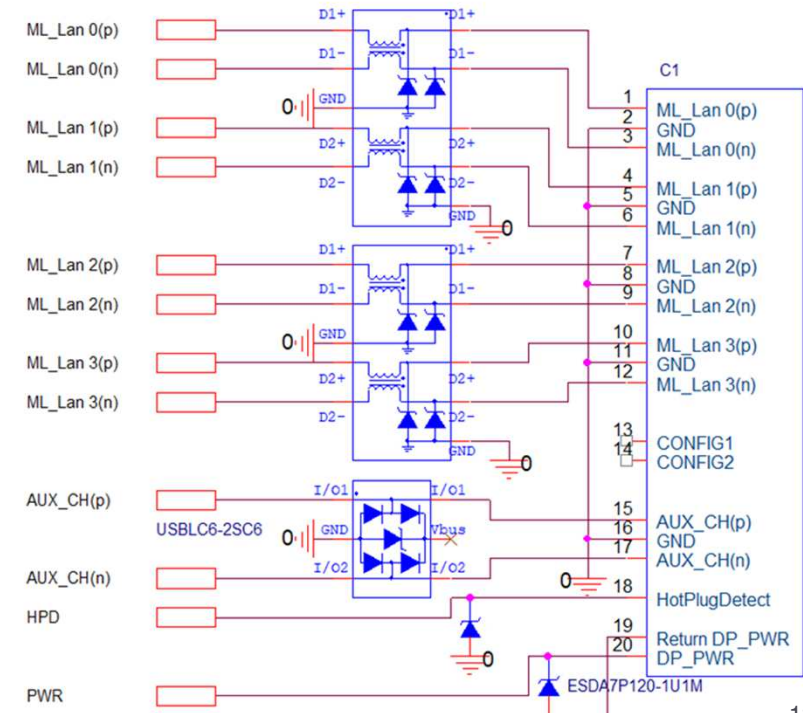
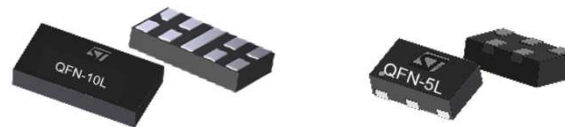

DisplayPort++ Control and auxiliary lines

DisplayPort to DVI, HDMI, or DisplayPort interface

Control lines and auxiliary bus needs	Product key parameters	ST solutions
Compatibility with low voltage GPU	IC input voltage: $1\text{ V} < V_{in} < 5.3\text{ V}$	<i>DPHDMI01-5M12 (*)</i>
Selection of DP or HDMI mode	Selection with 1 pin: AUX bus or DDC bus	
Capability to protect very sensitive GPU: To prevent overshoot/high surge applied to AUX_IC GPU pins during cable plug & deplug	Fast clamping protection: around 20 ns – 2 V VCL	
HPD standby activation	2.6 ms delay to avoid HPD_IRQ test failure	
Capability to drive poor quality cable	Buffer for I2C signal reshaping $t_r < 400\text{ ns}$	
Glitch filter	For HDMI clock stretching operation	
IEC 61000-4-2 level 4 (8 kV contact/15 kV air)	Contact discharge: $\geq 8\text{ kV}$ Air discharge: $\geq 15\text{ kV}$	

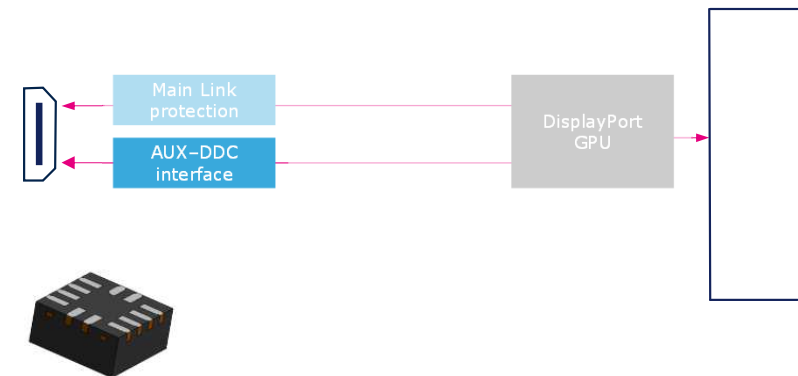

(*) Contact our sales office



DisplayPort++ HPD and PWR pins

Wide range of V_{RM} and I_{pp} surge capabilities IEC 61000-4-5 surge protection in small DFN package

HPD needs	Product key parameters	ST solutions
Voltage ≤ 3.6 V	V _{RM} = 5.5V	ESDA5-1F4 <u>ESDA7P120-1U1M</u>
Positive signal	Unidirectional	
Low speed signal	No constraints on capacitance	
IEC 61000-4-2 level 4 8 kV contact / 15 kV air	Contact discharge: >30 kV Air discharge: >30 kV	

PWR needs	Product key parameters	ST solutions
Voltage = 5V	V _{RM} ≥ 5 V	<u>ESDA7P120-1U1M</u>
Voltage = 12V	V _{RM} ≥ 12 V	
Voltage = 18V	V _{RM} ≥ 18 V	
Positive signal	Unidirectional	<u>ESDA13P70-1U1M</u>
Low speed signal	No capacitance constrains	<u>ESDA25P35-1U1M</u>
IEC 61000-4-2 level 4 8 kV contact / 15 kV air	Contact discharge: >30 kV Air discharge: >30 kV	

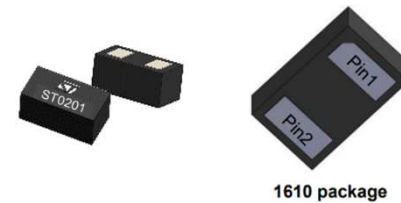

**HSP series bring integration and flexibility,
All sockets are ESD protected according to IEC 61000-4-2 level 4**

Needs for data	Product key parameters	ST solutions
Voltage : 900 mV peak (transceiver side) 900 mV peak to peak AC coupled (connector side)	$V_{RM}=3\text{ V}$	HSP053-4M5 (pitch 500 μm)
Positive signal on transceiver side	Unidirectional	
Data rate : up to 6 Gbps Eye diagram compliancy	Bandwidth > 8.7GHz Compliant with eye diagram	
IEC 61000-4-2 level 4	Contact discharge: 8 kV Air discharge: 15 kV	

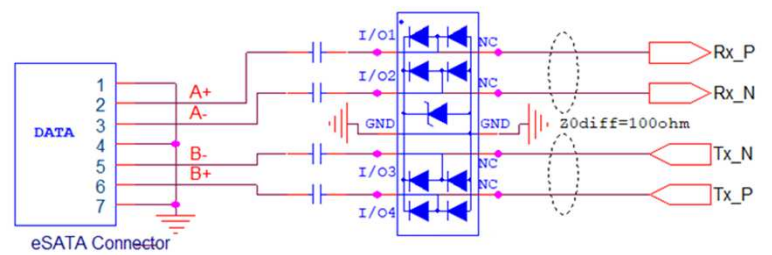

HSP series is compliant with all Ethernet lines
All sockets are ESD protected according to IEC 61000-4-2 level 4

Needs for Ethernet 10/100M	Product key parameters	ST solutions
Voltage: ≤ 3.0 V	$V_{RM} \geq 3.0$ V	USBLC6-4SC6 HSP053-4M5 (pitch 500 μ m)
Positive signal	Unidirectional	
Data rate: up to 100 Mbps Maximum equivalent frequency 100 MHz	Bandwidth > 800 MHz	
IEC 61000-4-2 level 4 8kV contact / 15 kV air	Contact discharge: ≥ 15 kV Air discharge: ≥ 15 kV	
Needs for Ethernet 1G / 10G	Product key parameters	ST solutions
1GEthernet voltage: 2.5V 10GEthernet voltage: 1.0V	$V_{RM} \geq 3.3$ V	HSP053-4M5 (pitch 500 μ m)
Positive signal	Unidirectional (bidirectional also suitable)	
Data rate per pair = 2.5 Gbps, 800 Msymbols/s Maximum equivalent frequency 500 MHz	Bandwidth > 5.0 GHz	
IEC 61000-4-2 level 4 – 8kV contact / 15 kV air	Contact discharge: ≥ 20 kV Air discharge: 30 kV	

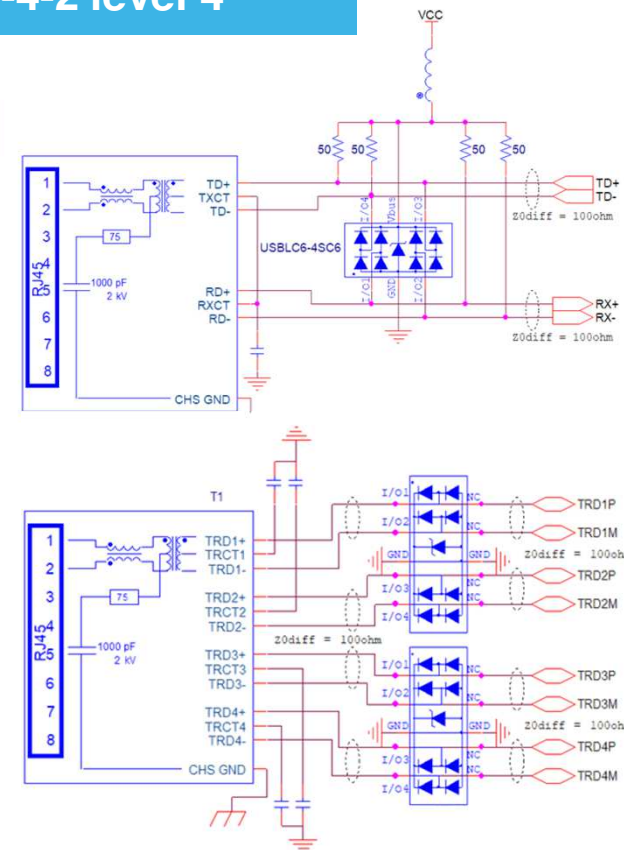

Power over Ethernet (PoE)

Flexibility in TVS selection according to requested IEC 6100-4-5 level

Needs	Product key parameters	ST solutions
Maximum voltage: 57 V	$V_{RM} = 58 \text{ V}$	<p><u>SMAJ58A</u></p> <p><u>SMA6J58A</u></p> <p><u>SM15T68A</u></p>
Operating ambient temperature up to 85°C	Leakage current rated at 85°C	
IEC 61000-4-5 (500 V–1.2/50 μs , 12 A–8/20 μs) (1 kV–1.2/50 μs , 24 A–8/20 μs)	<p>SMAJ58A: $I_{pp} = 19 \text{ A}$</p> <p>SMA6J58A: $I_{pp} = 33 \text{ A}$</p> <p>SM15T68A: $I_{pp} = 83 \text{ A}$</p>	

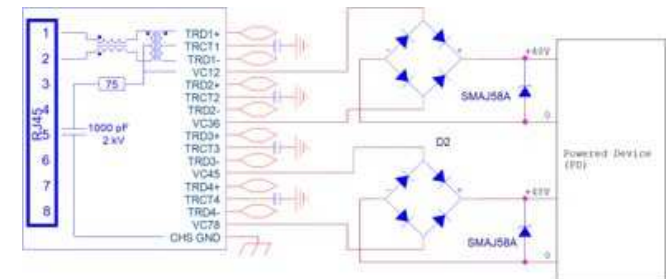

Always place the ESD protection close to ESD source
In this case, close to RS-232 connector

Needs for RS-232	Product key parameters	ST solutions
Voltage: ≤ 12V	$V_{RM} \geq 12V$	ESDA14V2BP6
Positive and negative signal	Bidirectional – 4 lines	
Maximum data rate : 256 kb/s Maximum equivalent frequency < 1 MHz	Low constraint on capacitance Typical line capacitance 25pF Bandwidth >> 1 MHz	
IEC 61000-4-2 level 4 8 kV contact / 15 kV air	Contact discharge: ≥8 kV Air discharge: ≥15 kV	

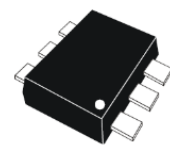
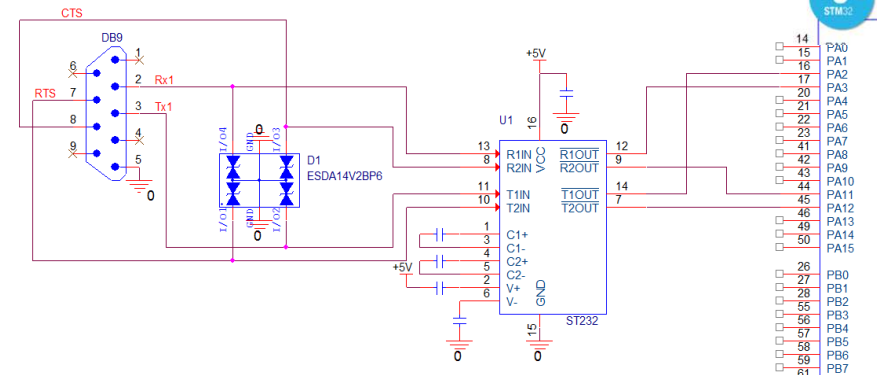
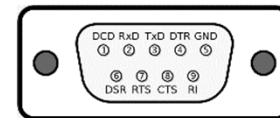

SOT666-6L

Always place the ESD protection close to ESD source
Here, close to RS-485 connector

Needs for RS-485	Product key parameters	ST solutions
Voltage range : -7V to + 12V	$V_{RM} \geq 12V$	ESDA14V2BP6
Positive and negative signal	Bidirectional – 4 lines	
Maximum data rate : 20 Mb/s Maximum equivalent frequency < 10 MHz	Low constraint on capacitance Typical line capacitance 25pF Bandwidth >> 10 MHz	
IEC 61000-4-2 level 4 8 kV contact / 15 kV air	Contact discharge: ≥ 8 kV Air discharge: ≥ 15 kV	

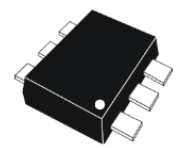
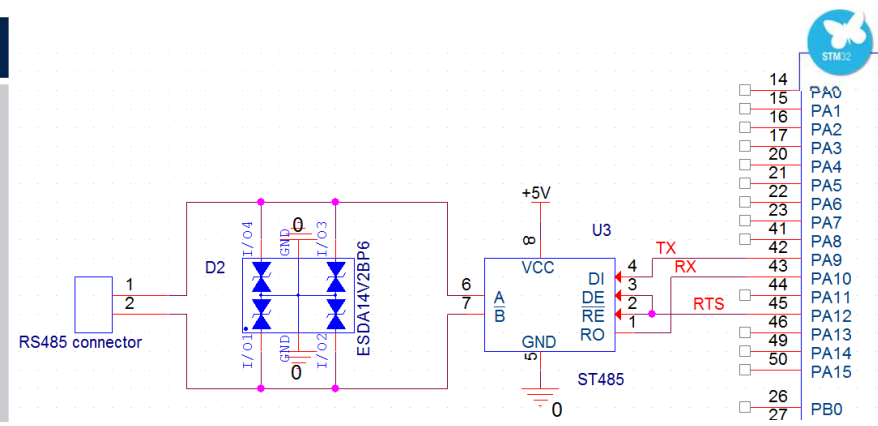

SOT666-6L

Complete product offer for SD card protection; Integrated EMI and ESD solution; Flexibility brought by ESD standalone products

Needs for Data / Clock	Product key parameters	ST solutions
Voltage $\leq 3.3V$	$V_{RM} \geq 3.0V$	EMIF06-MSD02N16 (SD 2.0)
Positive signal	Unidirectional	
IEC 61000-4-2 level 4 8 kV contact / 15 kV air	Contact discharge: ≥ 8 kV Air discharge: ≥ 15 kV	EMIF06-HSD03F3 (SD 3.0)
SD 2.0: $C_{max} = 40pF$ (including card cap. $\sim 10pF$)	$C < 20$ pF	
Avoid LTE, Wi-Fi, and Bluetooth antenna disturbance	Peak rejection frequency > 1950 MHz	HSP053-4M5 (SD 3.0)
SD 3.0: $C_{max} = 21pF$ (including card cap. $\sim 10pF$)	$C < 0.7pF$ Minimize Cline in order to give room for SD card	

Needs for V_{CC}	Product key parameters	ST solutions
Voltage $\leq 5V$	$V_{RM} = 5.5V$	ESDA5-1F4
Positive signal	Unidirectional (bidirectional also suitable)	
IEC 61000-4-2 level 4 8 kV contact / 15 kV air	Contact discharge = 30 kV Air discharge = 30 kV	

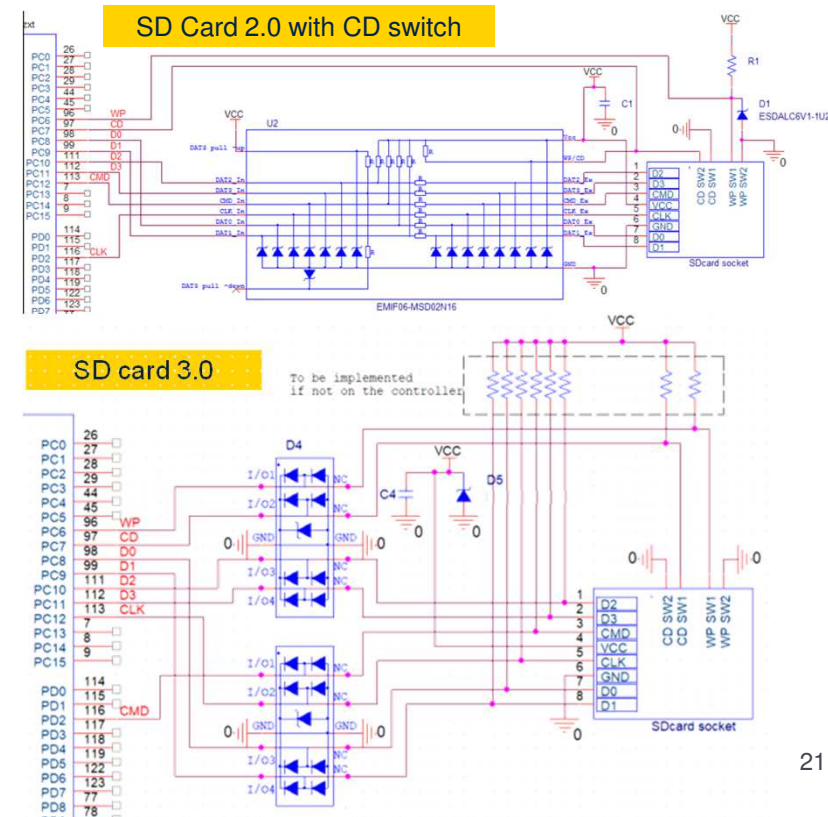

Integrated solution with both ESD protection and low pass filter Flexibility with single line product

Needs for CLK and D+	Product key parameters	ST solutions
Voltage ≤ 3.3 V	$V_{RM} \geq 3.3$ V	<u>ESDZL5-1F4</u>
Positive signal	Unidirectional (bidirectional also suitable)	
Data rate < 12 MHz	Bandwidth > 300 MHz	
Avoid to disturb LTE, WIFI, Bluetooth reception (700MHz to 3.8 GHz / 2.4GHz / 5GHz)	Rejection ≥ -10 dB (700 MHz to 5 GHz)	<u>ESDZV5-1BF4</u>
IEC 61000-4-2 level 4 8 kV contact / 15 kV air	Contact discharge: 8 kV - Air discharge: 15 kV	<u>EMIF03-SIM02M8</u>

Needs for SWP	Product key parameters	ST solutions
Voltage ≤ 3.3 V	$V_{RM} \geq 3.3$ V	<u>ESDAXLC5-1U2*</u>
Positive signal	Unidirectional	
$C_{LOAD} \max = 10$ pF (including PCB tracks and IC input)	Minimize Cline in order to give room for PCB design	
IEC 61000-4-2 level 4 8 kV contact / 15 kV air	Contact discharge: 8 kV - Air discharge: 15 kV	

* Under development

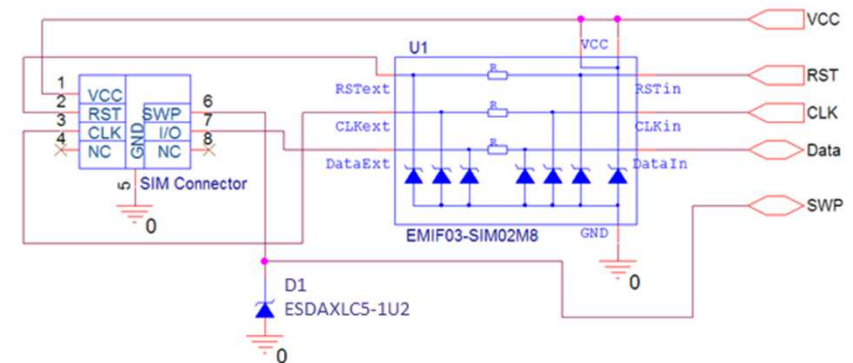

EMI filtering according to product's topology Flexibility brought by single line ESD protections

Needs for Data / Clock	Product key parameters	ST solutions
Voltage \leq 385 mV (high speed HS) Voltage \leq 1.3V (low power LP)	$V_{RM} \geq 3.3V$	<u>HSP053-4M5</u> <u>EMIF08-LCD04M16</u> (parallel link) <u>ECMF4-40A100N10</u> (differential lines)
Positive signal	Unidirectional (bidirectional also suitable)	
Data rate up to 1.5 Gbps	Bandwidth > 5 GHz	
Avoid to disturb LTE, Wi-Fi, Bluetooth reception	Rejection of frequencies above 700MHz	
	CMF Rejection \geq -15dB (2.4 GHz to 6.5 GHz)	
IEC 61000-4-2 level 4 8 kV contact / 15 kV air	Contact discharge: 8 kV - Air discharge: 15 kV	

Needs for I2C	Product key parameters	ST solutions
Line voltage range: 0 to 3.3V	$V_{RM} \geq 3.6V$	<u>ESDZV5-1BF4</u> (single line) <u>USBLC6-2SC6</u> (dual lines)
Positive signal	Unidirectional (bidirectional also suitable)	
Small consumption on digital communication	Capacitance <10 pF to reduce consumption	
Data rate: 3.4 Mbps	Bandwidth : > 700 MHz	
IEC 61000-4-2 level 4 8 kV contact / 15 kV air	Contact discharge: 8 kV - Air discharge: 15 kV	

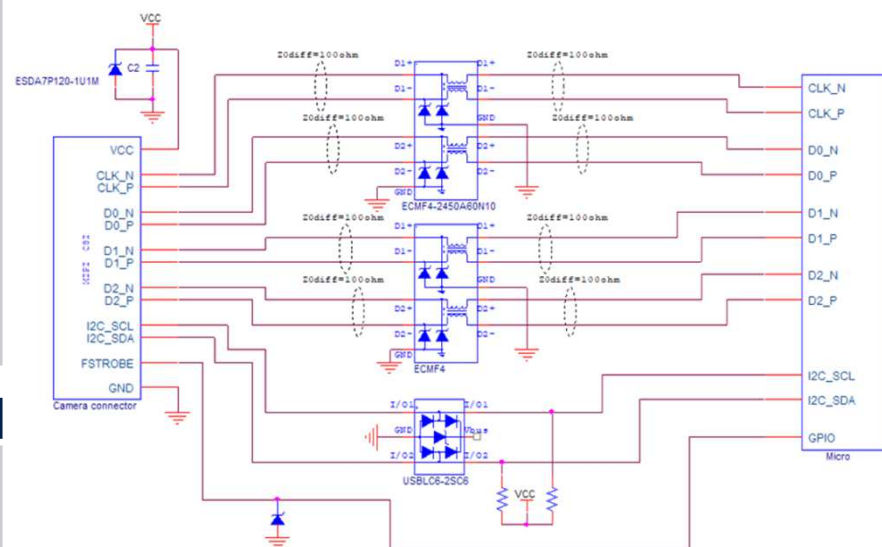

High efficiency EMI filtering All sockets ESD protected according to IEC 61000-4-2 level 4

Needs for parallel interface	Product key parameters	ST solutions
Voltage \leq 3.3V (high speed HS)	$V_{RM} \geq 3.3V$	<u>EMIF08-LCD04M16</u>
Positive signal	Unidirectional (bidirectional also suitable)	
Clock frequency < 33 MHz	Bandwidth > 400MHz (-6dB)	
Avoid to disturb LTE, Wi-Fi, Bluetooth reception	Rejection of 700MHz, 2.4 GHz and 5 GHz	
Needs for MIPI (Data / Clock)	Product key parameters	ST solutions
Voltage \leq 385 mV (high speed HS) Voltage \leq 1.3V (low power LP)	$V_{RM} \geq 3.6V$	<u>HSP053-4M5</u>
Positive signal	Unidirectional	
Data rate up to 1.5 Gbps	Bandwidth > 5 GHz	
Avoid to disturb Wifi antenna (2.4GHz / 5GHz)	CMF Rejection \geq -15dB (2.4 GHz to 6.5 GHz)	<u>ECMF4-40A100N10</u>
Needs for I2C	Product key parameters	ST solutions
Line voltage range: 0 to 3.3V	$V_{RM} \geq 3.3V$	<u>USBLC6-2SC6</u> <u>ESDZV5-1BF4</u> <u>ESDZL5-1F4</u>
Positive signal	Unidirectional (bidirectional also suitable)	
Small consumption on digital communication	Capacitance <10 pF to reduce consumption	
Data rate: 3.4 Mbps	Bandwidth : > 700 MHz	

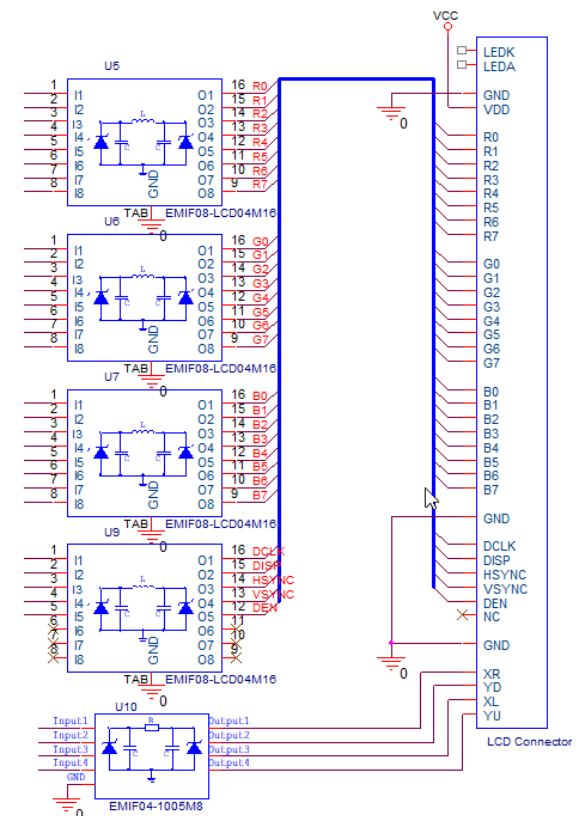

Audio interfaces

All sockets are ESD protected according to IEC 61000-4-2 level 4

Needs for speaker	Product key parameters	ST solutions
High power output ≤ 11 V (internal speaker)	$V_{RM} \geq 15$ V	<i>ESD141-1BU2 *</i>
Standard power < 3.6 V	$V_{RM} > 3.6$ V	<u>ESDZV5H-1BU2</u>
Audio Analog (alternative signal)	Bidirectional	
$f < 20$ kHz	No constraints on capacitance	

Needs for analog microphone	Product key parameters	ST solutions
Voltage ≤ 3.3 V	$V_{RM} \geq 3.3$ V	<u>ESDL031-1BF4</u>
Audio Analog	Bidirectional	<u>ESDZV5-1BF4</u>
$f < 20$ kHz	No constraints on capacitance	

Needs for digital microphone	Product key parameters	ST solutions
Voltage ≤ 3.3 V	$V_{RM} \geq 3.3$ V	<u>ESDZV5-1BF4</u> <u>ESDZL5-1F4</u>
Positive signal	Unidirectional (but bidirectional also suitable)	
Small consumption during digital communication	Capacitance < 10 pF	

* Under development

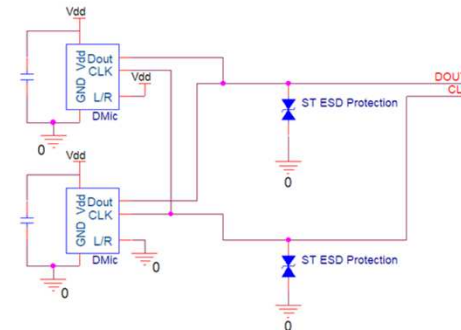
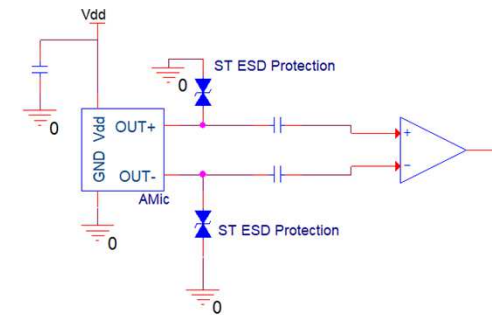
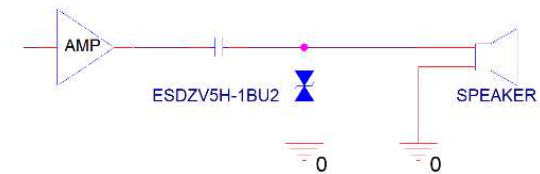

Buttons / Switches

All sockets are ESD protected according to IEC 61000-4-2 level 4
Very low clamping thanks to soft snapback type protection

Needs for switches	Product key parameters	ST solutions
MCU power supply, usually 3.3V or less	$V_{RM} \geq 5.5V$	ESDZV5-1BF4 (single line)
Digital positive signal	Unidirectional (bidirectional also suitable)	
Low frequency application	No constraints on capacitance Cline < 9.5pF	ESDZL5-1F4 (single line)
IEC 61000-4-2 level 4 8 kV contact / 15 kV air	Contact discharge: ≥ 15 kV Air discharge: ≥ 30 kV	
Avoid EMI (antenna desense)	Reject frequency > 700 MHz	EMIF01-1007AF4 (*)
IEC 61000-4-2 level 4 8 kV contact / 15 kV air	Contact discharge : up to 8 kV Air discharge : up to 15 kV	

(*) Contact our sales office

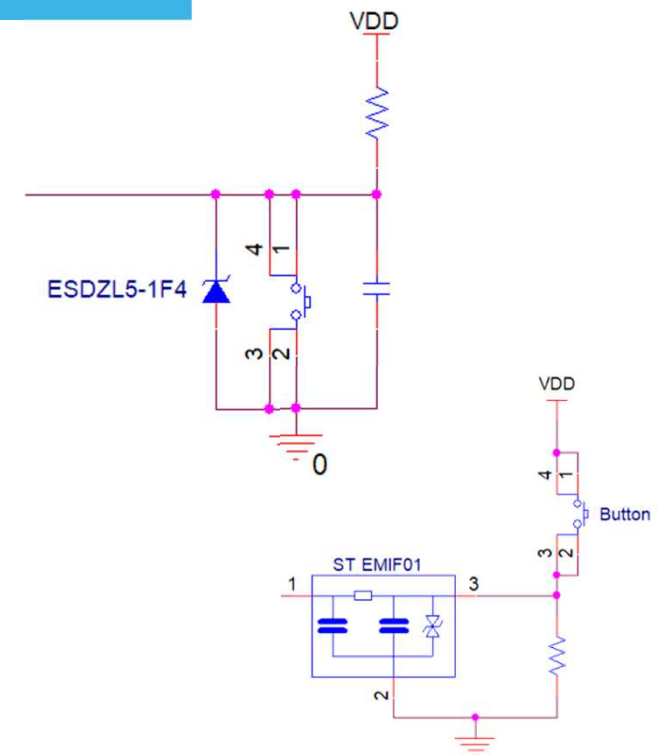

Charging connector & Battery

Wide range of Ipp surge capabilities
Flexibility with various voltages and package sizes

Power supply needs	Product key parameters	ST solutions in SMD
Voltage according to battery or specification	$V_{RM} \geq V_{bat}$ (generally $V_{bat} = 5\text{ V to }7\text{ V}$)	ESDAxP series (QFN)
Need to withstand 8/20 μs surge (IEC 61000-4-5)	Unidirectional	
IEC 61000-4-2 level 4 8 kV contact / 15 kV air	I_{PP} up to 120 A with $V_{RM} 7\text{ V}$	SM6F series (SOD128)
IEC 61000-4-2 level 4 8 kV contact / 15 kV air	Contact discharge: >30 kV Air discharge: >30 kV	

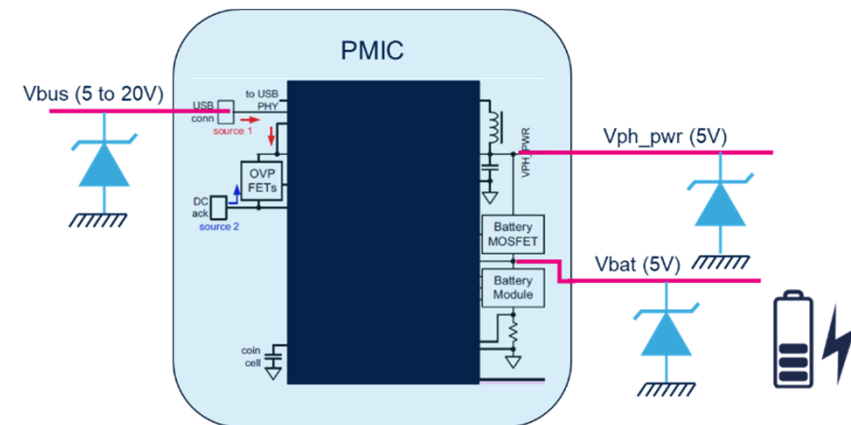

Glossary

- **ESD** : ElectroStatic Discharge
- **EOS**: Electrical OverStress
- **TVS**: Transient Voltage Suppressor diode
- **CMF** : Common Mode Filter
- **NVR** : Network Video Recorder
- **DVR** : Digital Video Recorder
- **CCTV**: Closed Circuit TeleVision
- **IP camera**: Internet Protocol camera
- **POE** : Power Over Ethernet
- **PTZ camera** : Pan-Tilt-Zoom camera
- **CVBS** : Composite Video Broadcast Signal

Our technology starts with You



Find out more at www.st.com

© STMicroelectronics - All rights reserved.

ST logo is a trademark or a registered trademark of STMicroelectronics International NV or its affiliates in the EU and/or other countries.

For additional information about ST trademarks, please refer to www.st.com/trademarks.

All other product or service names are the property of their respective owners.



life.augmented